

# Power Management Guide



# Power Management Guide

## Introduction and Contents

Texas Instruments (TI) offers complete power solutions with a full line of high-performance products. These products, which range from standard linear regulators to highly efficient DC/DC converters and battery management, are tailored to meet your design challenges. And, TI makes designing easier with leading-edge support tools such as the WEBENCH® Design Center, a broad selection of evaluation modules (EVMs), application notes, comprehensive technical documentation and more. TI also offers samples and small orders (shipped within 24 hours via authorized distributors) to help accelerate your time-to-market.

Included in this selection guide are design factors, featured products, graphic representations of portfolios and parametric tables.

For information about HiRel and military versions of Power Management products, please visit:

[www.ti.com/hirel](http://www.ti.com/hirel)

For information about automotive-qualified Power Management products, please visit:

[www.ti.com/automotive](http://www.ti.com/automotive)

### my.TI™ Account Register Today!

Keep current on:

- New product releases
- Design tools
- Samples
- Evaluation modules
- Guides
- System block diagrams

[www.ti.com/myTI](http://www.ti.com/myTI)

*It's easy and quick!*

## Table of Contents

### Portable and Line Power Solutions

- 3 Line Power Solutions
- 3 Portable Power Solutions

### AC/DC and Isolated DC/DC Power Supply

- 4 Overview
- 5 Power Factor Correction (PFC)
- 6 PWM and Resonant Controllers
- 11 Gate Drivers

### Power Modules (Non-Isolated)

- 15 Overview
- 16 Step-Down (Buck) Modules
- 21 Step-Up (Boost) and Negative Output Modules

### DC/DC Switching Regulators

- 22 Overview
- 23 DC/DC Step-Down Converters (Line and Portable Power)
- 31 Step-Up (Boost)/Flyback/SEPIC and Inverting Converters
- 34 Buck-Boost Converters
- 35 Controllers (External Switch)
- 39 Charge Pumps

### RF Power Solutions

- 41 Overview
- 42 RF DC/DC Converters
- 43 RF Power Detectors

### NexFET™ Power MOSFETs

- 44 Single and Dual N- and P-Channel

### Linear Regulators

- 48 Single and Dual LDOs

### Battery Management Products

- 51 Overview
- 52 Battery Charger Solutions
- 64 Battery Charger Protection
- 65 Battery Fuel Gauges
- 68 Battery and Peripheral Authentication
- 69 Battery (Li-Ion) Protection Solution
- 70 Wireless Power

### LED Lighting

- 74 General Illumination

### Display Power

- 78 LCD/OLED Display Bias Solutions
- 81 LED Driver – Backlight
- 85 Camera Flash LED Drivers
- 86 LED Driver – Signage/Linear

### Multi-Channel Power Management Units (PMUs)

- 88 Key Devices and Selection Guide

### Power Protection, Distribution and Monitoring

- 92 Hot Swap Control, Protection and Monitoring
- 96 Current-Limited and Non-Current-Limited Load Switches
- 98 Power-over-Ethernet
- 100 USB and Power Switches

### Digital Power Control Solutions

- 103 Complete Isolated Telecom DC/DC PMBus Power Solution
- 104 Isolated and Non-Isolated Digital Power Controllers

### Supervisor and Reset ICs

- 108 Selection Guide

### Sequencers

- 110 Selection Guide

### Push-Button Controllers

- 111 Product Highlights

### Current Power Monitors

- 111 Selection Guide

### DDR Power Solutions

- 112 Selection Guide

### Resources

- 113 Design Support
- 114 Packaging
- 116 Device Index
- 120 TI Worldwide Technical Support

# Portable and Line Power Solutions

## Line Power Solutions

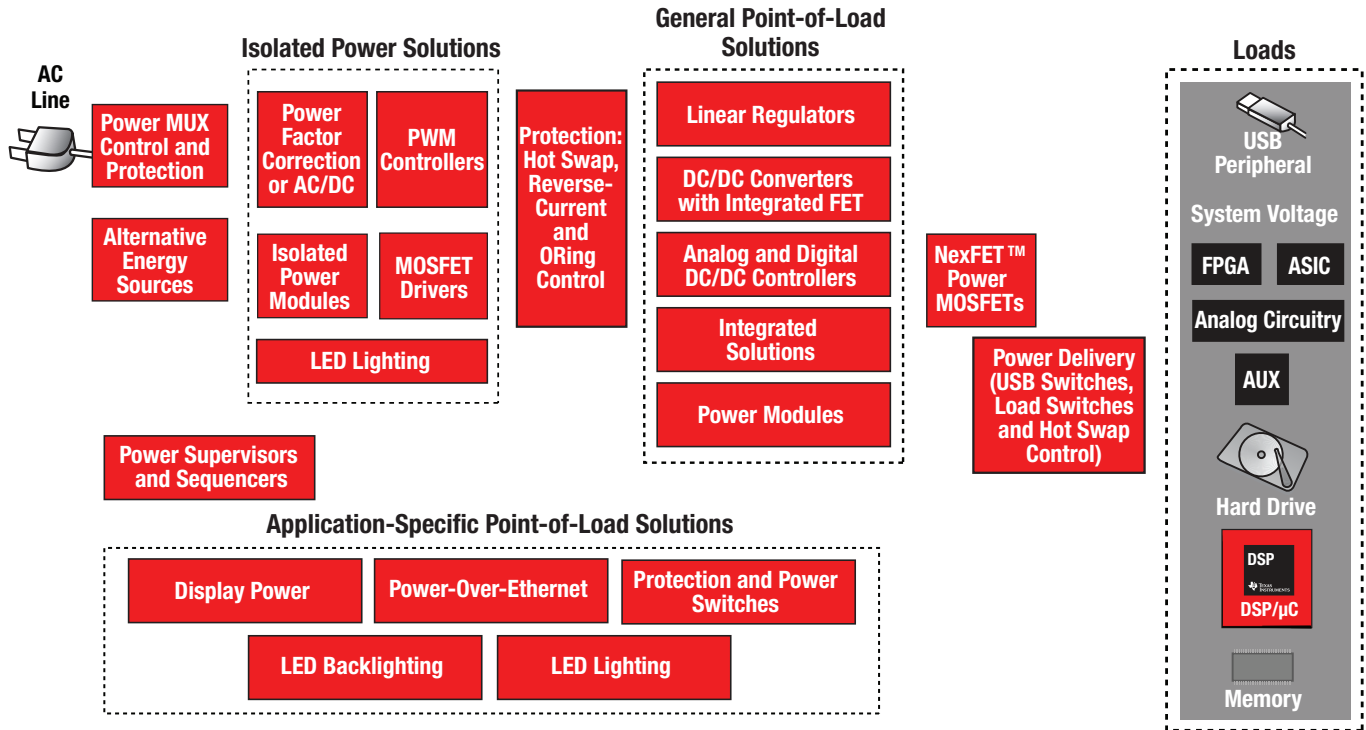

## Portable Power Solutions

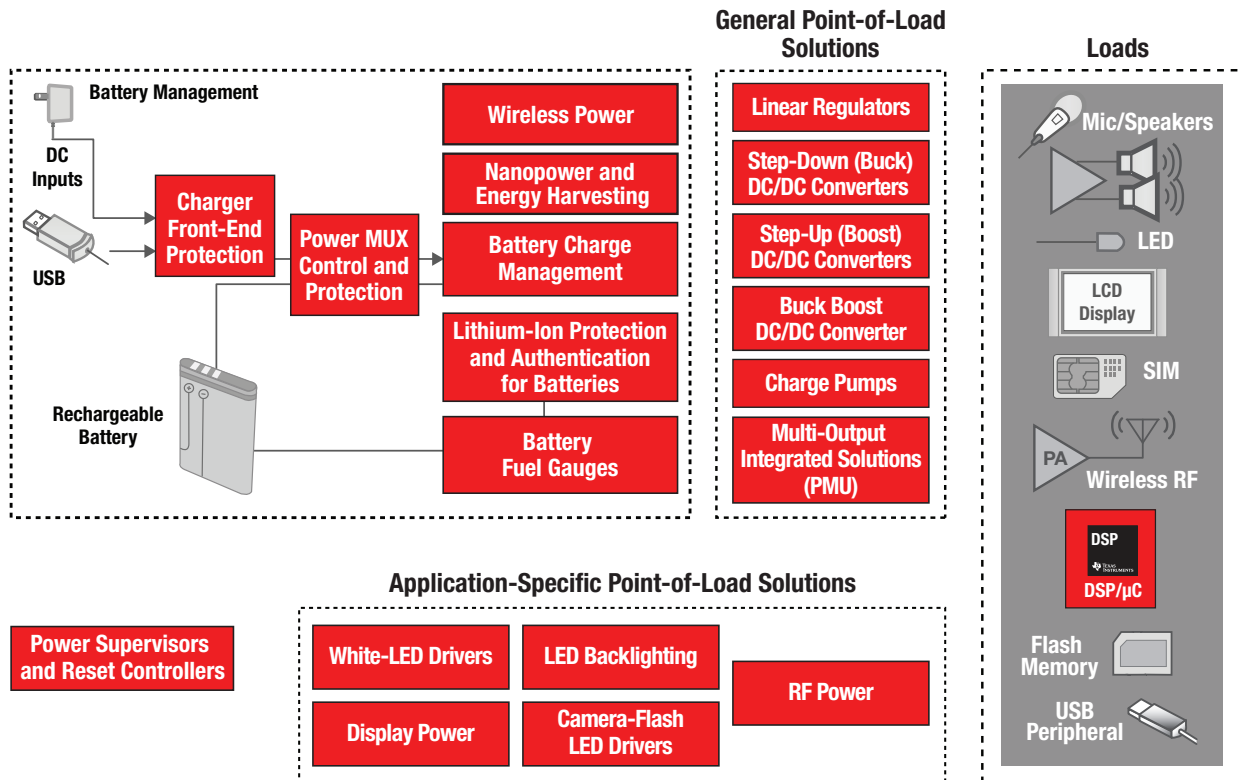

# AC/DC and Isolated DC/DC Power Supplies

## Overview

The TI portfolio of isolated power-conversion solutions covers the complete end-to-end power-supply building blocks from front-end PFC controllers to PWM controllers. These solutions support the most popular isolated-power topologies, including the advanced phase-shifted full-bridge. The portfolio also includes a variety of MOSFET gate drivers that support both primary and secondary MOSFET-driver applications, including synchronous-rectifier driver topologies and many other power-supply support products.

### Power-Supply Solutions

- PFC controllers:
  - Transition mode
  - Continuous-current mode
  - Interleaved
  - Bridgeless
- PWM controllers:
  - Single-ended: Flyback, forward, active-clamp
  - Double-ended: Half-bridge, phase-shifted full-bridge, push-pull, LLC half-bridge
  - UCD3K digital control solutions
- Gate drivers:
  - GaN FET driver
  - Synchronous-rectifier driver
  - Single low-side
  - Dual low-side
  - 110-V high-side/low-side
  - Synchronous-buck

### Design Factors

#### Control Method

**Average-Current Mode (ACM)** — Optimum control method to achieve PFC and low harmonic distortion.

**Transition Mode (TM)** — Simpler, inexpensive control with high peak currents and filtering requirements.

**Interleaved** — TM- and ACM-compatible multiphase, high-power, high-density topology. Delivers better EMI, smaller magnetics and reduced ripple currents.

**Zero-Voltage-Transition (ZVT) Mode** — A type of soft-switching technique, which reduces EMI and allows for higher frequency operations.

#### Protection

- Overvoltage protection (OVP) prevents output capacitor, switches and load from overcharge condition
- Soft-start (programmable) provides controlled start-up
- Overcurrent protection (OCP) provides protection during overload conditions

#### Performance

- Voltage feed-forward for linearized performance and faster transient response over wide line voltage range
- Multiplier linearity and zero power detect functions improve light load operation
- Onboard high output current drive capability without external MOSFET drivers

### Flexibility

- Versatile advanced PWM controllers and bias supply converters for high-performance secondary-side control
- Ability to work with a wide line voltage range
- Different levels of undervoltage lockout thresholds for self bias and auxiliary bias applications
- Ability to synchronize controllers to eliminate noise issues

### Power Level

- IEC requirements are applicable to all power supplies above 75 W
- Higher power converters may require zero-current-switching (ZCS) and ZVT-switching techniques to achieve high efficiencies
- Some of the simpler control techniques not usable at high power levels

### Features

- From 50 W to 5 kW, TI PFC controllers deliver EN61000-3-2 compliance
- Industry standard architecture
- Deliver PF > 0.993
- Integrated controllers with on-chip start-up circuit and MOSFET drivers for high-density primary-side control
- Integrated synchronous rectifier control with pre-bias operation for monotonic start-up
- Superior applications support

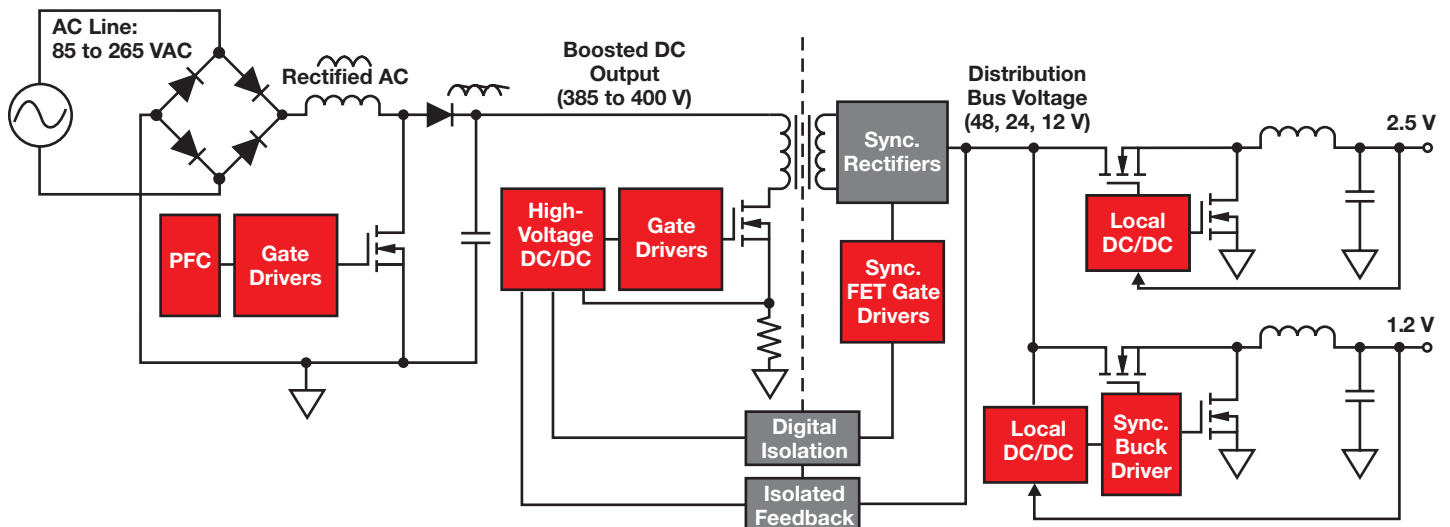

# AC/DC and Isolated DC/DC Power Supplies

## Power Factor Correction (PFC)

### Interleaved PFC

Interleaved PFC is gaining popularity in external and embedded-type power-supply architectures. It is exceptionally flexible and provides many cost-saving features such as passive-component size reductions, smaller EMI filtering components and higher efficiencies. TI offers both transition mode (UCC28063) and continuous conduction mode (CCM) (UCC28070) control methods.

Other benefits of interleaving include scalability and ultrathin designs. Scalability allows for addressing many different power levels and applications.

### Why Interleave?

- Lower system cost from ripple-current cancellation
- Enables ultraslim and high-density designs
- Lower total inductor volume
- Smaller or lower-cost EMI filter and output capacitors
- Facilitates higher efficiency

### Applications

- Digital TV
- Telecom power supplies and rectifiers
- Professional and consumer audio
- Merchant power supplies
- Air conditioning and refrigeration compressors
- Variable-speed motors
- Low-profile power-supply applications

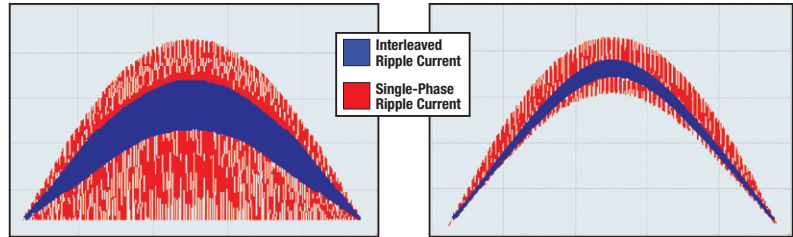

UCC28063 transition mode PFC with Natural Interleaving™ technique.

UCC28070 continuous conduction mode PFC.

Get more information: [www.ti.com/product/UCC28063](http://www.ti.com/product/UCC28063) or [UCC28070](http://www.ti.com/product/UCC28070)

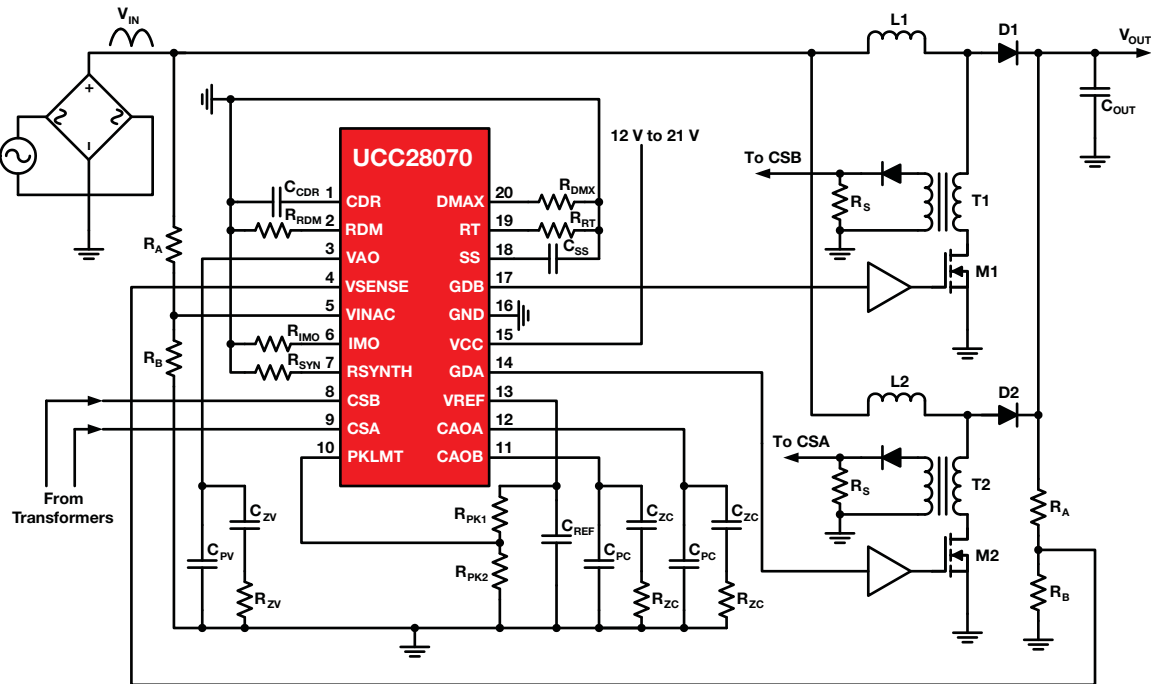

Typical application for UCC28070 continuous conduction mode PFC.

# AC/DC and Isolated DC/DC Power Supplies

## PWM and Resonant Controllers

### Product Highlights

#### UCC28950

- Green advanced phase-shifted full-bridge and synchronous rectifier controller

#### UCC28250

- Advanced PWM controller with pre-bias start-up and synchronous rectification

#### UCC28700/1/2/3

- Constant-voltage, constant-current PWM with primary-side regulation, <30-mW no-load power

#### UCC28710/1

- Constant-voltage, constant-current PWM with primary-side regulation with HV start-up, <10-mW no-load power

#### UCC2897A

- Active clamp forward

#### UCC25600

- LLC resonant controller

#### UCC28610

- Advanced green-mode flyback controller

#### LM5023

PREVIEW

- Quasi-resonant flyback controller with low standby power and 1% regulation

#### LM5046

- Phase-shifted full-bridge and SR controller with integrated drivers and high-voltage start-up

#### LM5035/39

- Half-bridge controller with integrated high-voltage start-up and drivers

### Green-Mode Controllers (Up to 150 W)

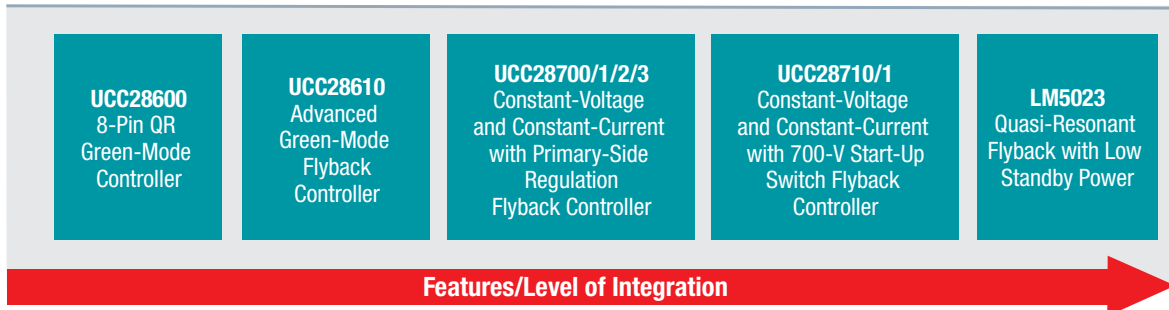

### Low- to Medium-Power PWM Controllers (25 W to 350 W)

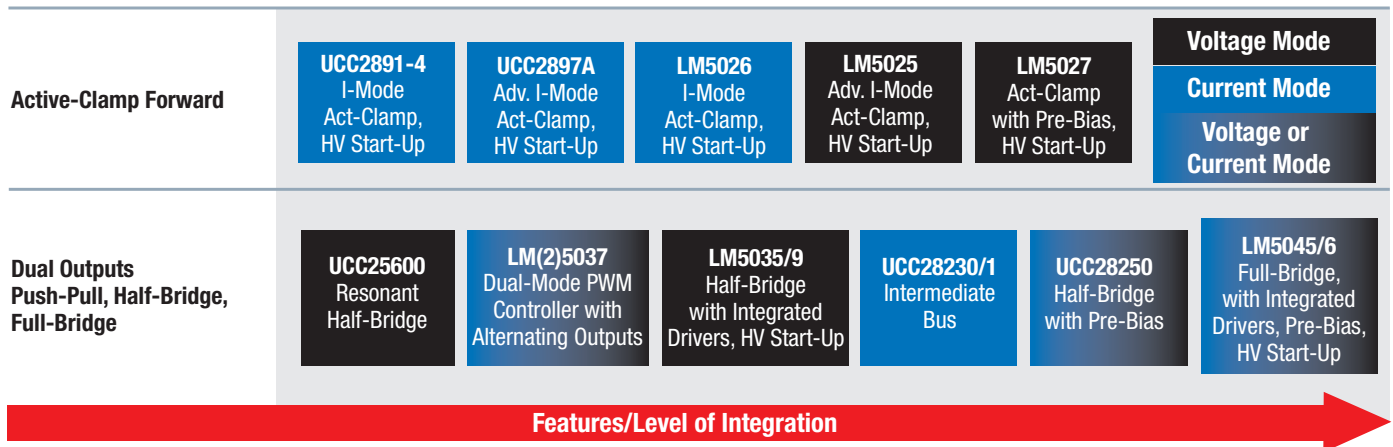

# AC/DC and Isolated DC/DC Power Supplies

## PWM and Resonant Controllers

### Medium- to High-Power PWM Controllers (>300 W)

Soft-Switching, ZVT, ZVS (Phase-shifted full-bridge, resonant, active-clamp forward)	<b>UCC2897A</b> Adv. I-Mode Act-Clamp, HV Start-Up	<b>LM5026</b> Adv. V-Mode Act-Clamp, HV Start-Up	<b>LM5026</b> Adv. I-Mode Act-Clamp, HV Start-Up	<b>UCC2895</b> BiCMOS Adv. $\phi$ -Shift PWM Controller	<b>UCC28950</b> Green $\phi$ -Shift Full-Bridge Controller with Synchronous Rectification	<b>LM5046</b> $\phi$ -Shift Full-Bridge Integrated Drivers, HV Start-Up, Pre-Bias
Push-Pull, Half-Bridge, Full-Bridge	<b>UCC28230/1</b> Intermediate Bus	<b>LM(2)5037</b> Dual-Mode PWM Controller with Alternating Outputs		<b>UCC25600</b> Resonant Half-Bridge	<b>UCC28250</b> Half-Bridge with Pre-Bias	<b>LM5045</b> Full-Bridge Controller Integrated Drivers, HV Start-Up, Pre-Bias
Secondary Side Control	<b>Voltage Mode</b> <b>Current Mode</b> <b>Voltage or Current Mode</b>			<b>UCC28250</b> Half-Bridge with Pre-Bias Operation	<b>UCC28950</b> Green $\phi$ -Shift Full-Bridge Controller with Synchronous Rectification	

Features/Level of Integration 

### Most Integrated Family of Full-Bridge PWM Controllers

#### LM5045, LM5046

#### Key Features

- High-current, 2-A full-bridge gate drivers
- Intelligent sync rectifier start-up for linear turn-on into prebiased loads
- 5-V sync rectifier drive for digital isolators or transformer

- 105-V high-current start-up regulator
- Independently programmable synchronous rectifier delays (LM5045)
- Programmable resonant times for ZVS operation (LM5046)

#### Applications

- Telecom power supplies
- Industrial power supplies
- High-density power modules

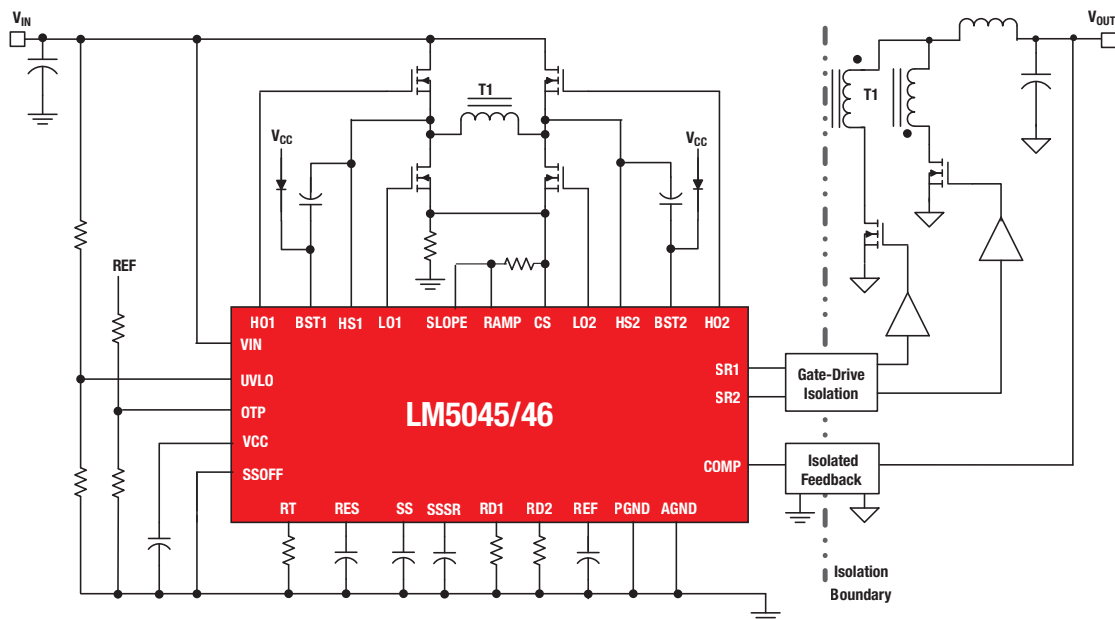

Get more information: [www.ti.com/product/LM5045](http://www.ti.com/product/LM5045) or [LM5046](http://www.ti.com/product/LM5046)

# AC/DC and Isolated DC/DC Power Supplies

## PWM and Resonant Controllers

### Green Advanced Phase-Shifted Full-Bridge and Synchronous Rectifier Controller

#### UCC28950

The UCC28950 phase-shifted full-bridge controller offers best-in-class efficiency in today's high-performance power systems. The UCC28950 implements advanced full-bridge control along with active control of the synchronous rectifier's output stage. The primary-side signals allow programmable delays to ensure ZVS operation over wide load current and input voltage range, while the load current naturally tunes the secondary-side synchronous rectifier's switching delays, maximizing overall system efficiency.

#### Key Features

- Optimized for 90+ efficiency standards
- User-programmable operation in DCM mode with lowered frequency at light load (burst)
- Programmable ramp compensation allows current- or voltage-mode control
- Adaptive ZVS switching over wide input/output range
- Optimal timing outputs for synchronous-rectifier drivers
- Sync in and sync out with 90% phase shift for master/slave interleaved operation of two modules

#### Applications

- Phase-shifted full-bridge converters
- Server, telecom power supplies
- Industrial power systems
- High-density power architectures
- Solar inverters
- Electric vehicles
- DC motor drives

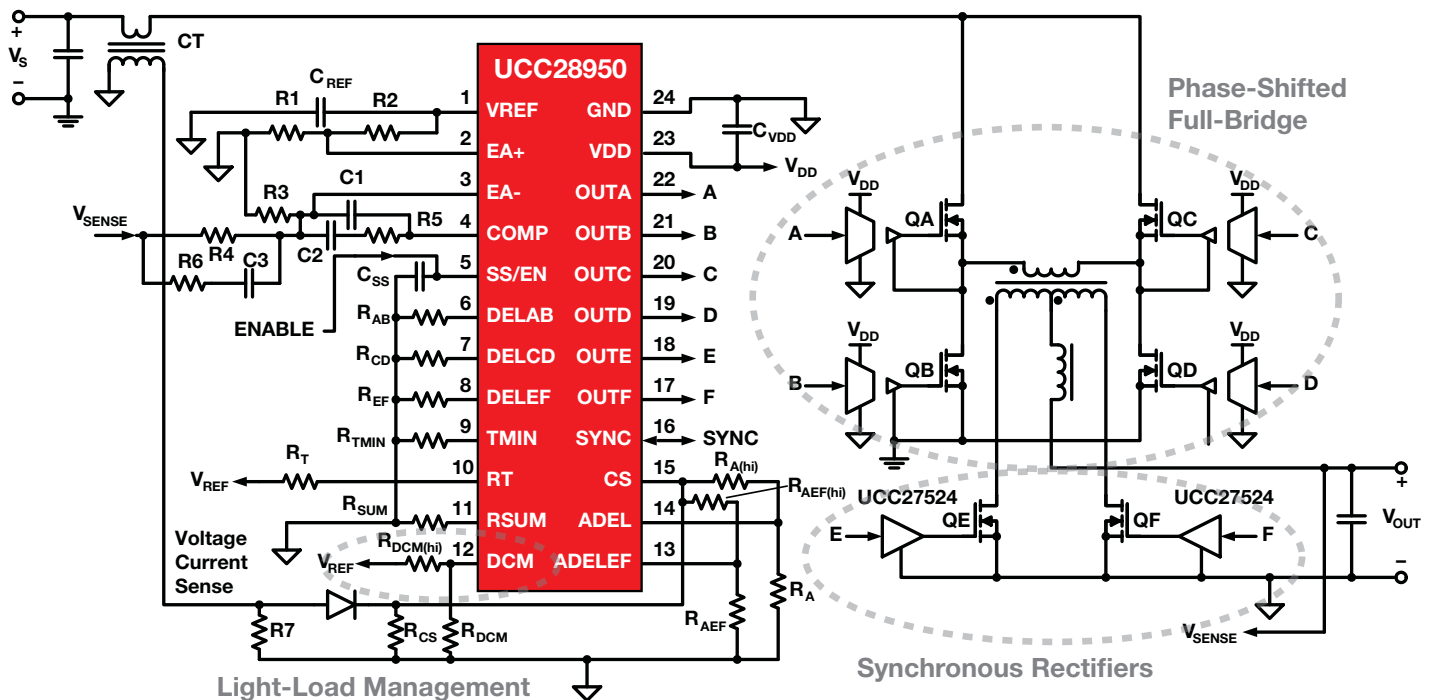

Get more information: [www.ti.com/product/UCC28950](http://www.ti.com/product/UCC28950)



# AC/DC and Isolated DC/DC Power Supplies

## PWM and Resonant Controllers

### Selection Guide

Device <sup>1</sup>	Typical Power Level (W)	Control Method			Topologies	Maximum Practical Frequency	Supply Voltage (V)	110-V Start-Up Circuit	Soft Start	Output Drive (Sink/Source) (A)	Package(s)	Price*
		Voltage Mode	Current Mode	Avg. Current Mode								
<b>Auxiliary Bias Supplies</b>												
TPS55010	<2	✓			Fly-Buck™ (Forward Flyback)	2 MHz	2.95 to 6		✓	—	16-QFN	1.65
UCC25230	1 to 2				Buck, Fly-Buck (Forward Flyback)	445 kHz	12 to 75		✓	—	8-SO8	1.35
LM34927/6/5	3 to 7		Note 2		Buck, Isolated Buck	1 MHz	9 to 100			0.6/0.3/0.15	8-LLP/PSOP	1.65
LM5017	3 to 7		Note 2		Buck, Isolated/Non-Isolated Flyback	1 MHz	9 to 100			0.6	8-LLP/PSOP	1.65
<b>Intermediate Bus Controllers</b>												
UCC28230/1	150 to 500				Half-Bridge, Full-Bridge	2 MHz	−0.3 to 20		✓	0.2/0.2	12-SO8, 14-TSSOP	1.20
<b>General-Purpose Single-Ended Controllers</b>												
UCC3888/89	<10	✓			Flyback (SEPIC, Cuk)	250 kHz	9		✓	0.2/0.15	8-SOIC-W/DIL (PDIP)	0.59
LM5020	10 to 100		✓		Buck, Boost, Flyback (SEPIC, Cuk)	1 MHz	13 to 100	✓	✓	1	10-MSOP/QFN	0.90
LM5021	10 to 100		✓		Flyback (SEPIC, Cuk), Forward (D > 50%)	1 MHz	8 to 30		✓	0.7	8-MSOP	0.66
LM5022	25 to 100		✓		Buck, Boost, Flyback (SEPIC, Cuk)	2 MHz	6 to 60		✓	1	10-MSOP	1.13
UCC3800/1/2/3/4/5	10 to 200	✓	✓		Buck, Boost, Flyback (SEPIC, Cuk), Fwd (Including 2-Switch Fwd), Forward (D > 50%)	1 MHz	4.1 to 15		✓	1/1	8-TSSOP/SOIC/DIL (PDIP)	1.35
UCC3807-1-2-3	10 to 200	✓	✓		Buck, Boost, Flyback (SEPIC, Cuk), Forward (D > 50%)	1 MHz	6.9 to 15		✓	1/1	8-SOIC/DIL (PDIP)	1.50
UCC3809-1-2	10 to 200	✓	✓		Buck, Boost, Flyback (SEPIC, Cuk), Forward (D > 50%)	1 MHz	8 to 19		✓	0.8/0.4	8-MSOP/TSSOP/SOIC/DIL (PDIP)	0.85
UCC3813-0/1/2/3/4/5	10 to 200	✓	✓		Buck, Boost, Flyback (SEPIC, Cuk), Fwd (Including 2-Switch Fwd) <sup>3</sup> , Forward (D > 50%) <sup>3</sup>	1 MHz	7.2 to 15 <sup>3</sup>		✓	1/1	8-TSSOP/SOIC/DIL (PDIP)	0.80
LM5025/A/B/C	50 to 250	✓			Act-Clamp Fwd/Flyback	1 MHz	8 to 100	✓	✓	3/3	16-TSSOP/QFN	1.25
LM5026	50 to 250		✓		Act-Clamp Fwd/Flyback	1 MHz	8 to 100	✓	✓	3/3	16-TSSOP/QFN	1.30
LM5027/A	50 to 250	✓			Act-Clamp Fwd/Flyback	1 MHz	8 to 105	✓	✓	2/2	24-TSSOP, 20-QFN	1.75
UCC3884	50 to 250	✓	✓		Buck, Boost, Flyback (SEPIC, Cuk), Forward (D > 50%)	1 MHz	8.9 to 15		✓	1/0.5	16-SOIC/DIL (PDIP)	1.60
UCC38C40/1/2/3/4/5	10 to 250	✓	✓		Buck, Boost, Flyback (SEPIC, Cuk), Forward (D > 50%)	1 MHz	5 Options			1/1	8-MSOP/SOIC/DIL (PDIP)	0.95
TL3842B/3B/4B/5B	30 to 350	✓	✓		Buck, Boost, Flyback (SEPIC, Cuk), Forward (D > 50%)	500 kHz	10 to 30			1/1	8/14-SOIC, 8-DIL (PDIP)	0.54
UC3842A/3A/4A/5A	30 to 350	✓	✓		Buck, Boost, Flyback (SEPIC, Cuk), Forward (D > 50%)	500 kHz	10 to 30			1/1	8/14-SOIC, 8-DIL (PDIP)	0.80
UC28023	50 to 750	✓	✓		Buck, Boost, Flyback (SEPIC, Cuk), Forward (D > 50%)	1 MHz	9 to 30		✓	1.5/1.5	16-SOIC-W/DIL (PDIP)	1.35
UC3823	50 to 750	✓	✓		Buck, Boost, Flyback (SEPIC, Cuk), Forward (D > 50%)	1 MHz	9 to 30		✓	1.5/1.5	16-SOIC-W/DIL (PDIP), 20-PLCC	1.60
UC3823A/B	50 to 750	✓	✓		Buck, Boost, Flyback (SEPIC, Cuk), Forward (D > 50%)	1 MHz	9 to 22		✓	2/2	16-SOIC-W/DIL (PDIP), 20-PLCC	4.90
<b>Wide-Input Range Voltage Mode Controllers</b>												
UCC35701/2	25 to 250	✓			Flyback (SEPIC, Cuk), Fwd (Including 2-Switch Fwd), Forward (D > 50%)	700 kHz	8.8 to 15		✓	1.2/1.2	14-TSSOP/SOIC/DIL (PDIP)	2.95
UCC35705/6	25 to 250	✓			Boost, Flyback (SEPIC, Cuk), Fwd (Including 2-Switch Fwd), Forward (D > 50%)	4 MHz	8.0 to 15			0.1/0.1	8-MSOP/SOIC/DIL (PDIP)	0.75
<b>Dual Output Controllers</b>												
LM5015	30 to 250		✓		Fwd (Including 2-Switch Fwd)	750 kHz	4.25 to 75		✓	1	14-TSSOP	2.05
LM5032	30 to 250		✓		Flyback (SEPIC, Cuk), Fwd (Including 2-Switch Fwd)	1 MHz	13 to 100	✓	✓	2.5/2.5	16-TSSOP	1.55
LM5034	30 to 250		✓		Flyback (SEPIC, Cuk), Fwd (Including 2-Switch Fwd)	1 MHz	8 to 100	✓	✓	2.5/2.5	20-TSSOP	1.90
UC3824	50 to 250	✓	✓		Push-Pull, Half-Bridge, Full-Bridge	1 MHz	9 to 30		✓	1.5/1.5	16-SOIC-W/DIL (PDIP)	4.55
UCC28089	25 to 250				Interleaved Fwd/Flyback/Boost, Push-Pull, Half-Bridge, Full-Bridge	500 kHz	8 to 15		✓	0.5/1.0	8-SOIC	0.65
LM5035/A/B/C	50 to 300	✓			Half-Bridge	2 MHz	8 to 100	✓	✓	2/2	28-TSSOP, 20-HTSSOP, 24-QFN	1.90
LM(2)5037	30 to 300	✓	✓		Push-Pull, Half-Bridge, Full-Bridge	2 MHz	13 to 75/100	✓	✓	1.2/1.2	16-TSSOP	1.35/1.62
LM5039	50 to 300	✓			Half-Bridge	2 MHz	8 to 100	✓	✓	2/2	20-HTSSOP, 24-QFN	1.90
LM5045	50 to 400	✓	✓		Full-Bridge	2 MHz	14 to 100	✓	✓	1.5/2	28-HTSSOP/QFN	2.25
TL494 or TL594	50 to 500	✓			Buck, Boost, Flyback (SEPIC, Cuk), Fwd (Including 2-Switch Fwd), Forward (D > 50%), Interleaved Fwd/Flyback/Boost, Push-Pull, Half-Bridge, Full-Bridge	300 kHz	7 to 40			0.2/0.2	16-TSSOP/SOIC/DIL (PDIP)	0.23
TL598	50 to 500	✓			Buck, Boost, Flyback (SEPIC, Cuk), Fwd (Including 2-Switch Fwd), Forward (D > 50%), Interleaved Fwd/Flyback/Boost, Push-Pull, Half-Bridge, Full-Bridge	300 kHz	7 to 40			0.2/0.2	16-SOIC/DIL (PDIP)	0.81

<sup>1</sup>UC2xxx and UCC2xxx devices are extended temperature-range versions of the UC3xxx and UCC3xxx devices.

<sup>2</sup>Continuous On-Time architecture.

<sup>3</sup>Value varies by part number suffix. Please check datasheet.

\*Suggested resale price in U.S. dollars in quantities of 1,000.

New devices are listed in **bold red**.  
Preview devices are listed in **bold teal**.

# AC/DC and Isolated DC/DC Power Supplies

## PWM and Resonant Controllers

### Selection Guide (Continued)

Device <sup>1</sup>	Typical Power Level (W)	Control Method			Topologies	Maximum Practical Frequency	Supply Voltage (V)	110-V Start-Up Circuit	Soft Start	Output Drive (Sink/Source) (A)	Package(s)	Price*
		Voltage Mode	Current Mode	Avg. Current Mode								
<b>Dual Output Controllers (Continued)</b>												
UC3524A	50 to 500	✓			Push-Pull, Half-Bridge, Full-Bridge	250 kHz	8 to 40		✓	0.2/0.2	16-SOIC/DIL (PDIP)	1.70
UC3525B - UC3526A	50 to 500	✓			Push-Pull, Half-Bridge, Full-Bridge	250 kHz	8 to 40		✓	0.2/0.2	16-SOIC/DIL (PDIP), 20-PLCC	1.05
UC3827-1/-2	50 to 500		✓		I-Fed/V-Fed Push-Pull	450 kHz	8.4 to 20		✓	1/0.8	24-SOIC-W/DIL (PDIP), 28-PLCC	3.50
UCC3808-1/-2/A-1/A-2	50 to 500		✓		Push-Pull, Half-Bridge, Full-Bridge	1 MHz	4.3 to 15		✓	1.0/0.5	8-TSSOP/SOIC/DIL (PDIP)	1.30
UCC38083/4/5/6	50 to 500		✓		Push-Pull, Half-Bridge, Full-Bridge	1 MHz	8.3 to 15		✓	1.0/0.5	8-TSSOP/SOIC/DIL (PDIP)	1.10
UCC3810	50 to 500	✓	✓		Buck, Boost, Flyback (SEPIC, Cuk), Fwd (Including 2-Switch Fwd), Interleaved Fwd/Flyback/Boost	1 MHz	8.3 to 11			1/1	16-SOIC/DIL (PDIP)	1.85
LM5030	50 to 600		✓		Act-Clamp Fwd/Flyback, Half-Bridge, Full-Bridge	1 MHz	14 to 100	✓	✓	1.5/1.5	20-TSSOP	1.10
LM5033	50 to 600	✓			Push-Pull, Half-Bridge, Full-Bridge	1 MHz	15 to 100	✓	✓	1.5/1.5	10-MSOP/QFN	1.00
UC28025	50 to 750	✓	✓		Push-Pull, Half-Bridge, Full-Bridge	1 MHz	9 to 30		✓	1.5/1.5	16-SOIC-W/DIL (PDIP)	1.35
UC3825	50 to 750	✓	✓		Push-Pull, Half-Bridge, Full-Bridge	1 MHz	9 to 30		✓	1.5/1.5	16-SOIC-W/DIL (PDIP), 20-PLCC	1.60
UC3825A/B	50 to 750	✓	✓		Push-Pull, Half-Bridge, Full-Bridge	1 MHz	9 to 22		✓	2/2	16-SOIC-W/DIL (PDIP), 20-PLCC	2.65
UC3846/56	50 to 750	✓	✓		Push-Pull, Half-Bridge, Full-Bridge	1 MHz	8 to 40		✓	0.5/0.5	16-SOIC-W/DIL (PDIP), 20-PLCC	1.60
UCC3806	50 to 750	✓	✓		Push-Pull, Half-Bridge, Full-Bridge	350 kHz	7 to 15		✓	0.5/0.5	16-SSOP/TSSOP/SOIC/SOIC-W/DIL (PDIP), 20-PLCC	4.10
LM5041/A/B	50 to 800		✓		I-Fed/V-Fed Push-Pull	1 MHz	15 to 100	✓	✓	1/5/1.5	16-TSSOP/QFN	2.15
<b>UCC28250/1</b>	100 to 800	✓	✓		Fwd (Including 2-Switch Fwd), Interleaved Fwd/Flyback/Boost, Act-Clamp Fwd/Flyback, Push-Pull, Half-Bridge	1 MHz	4.7 to 17		✓	—	20-TSSOP/QFN	1.70
UCC28220/1	50 to 800		✓		Interleaved Fwd/Flyback/Boost	1 MHz/ch.	8 to 14.5	✓	✓	0.01/0.01	16-TSSOP/SOIC	1.60
<b>Soft-Switching, ZVT and ZVS Controllers</b>												
LM5046	50 to 400	✓	✓		Φ-Shifted FB	2 MHz	14 to 100	✓	✓	2/2	28-HTSSOP/QFN	2.45
UCC3580-1/-2/-3/-4	50 to 500	✓			Forward (D > 50%), Act-Clamp Fwd/Flyback	500 kHz	7 to 15		✓	0.5/1, 0.3/0.3	16-SOIC/DIL (PDIP)	2.40
UCC2891/3	75 to 600		✓		Forward (D > 50%), Act-Clamp Fwd/Flyback	1 MHz	8.5 to 14.5	✓	✓	2/2, 2/2	16-TSSOP/SOIC	1.50
UCC2892/4	75 to 600		✓		Forward (D > 50%), Act-Clamp Fwd/Flyback	1 MHz	8.5 to 14.5		✓	2/2, 2/2	16-TSSOP/SOIC	1.50
UCC2897A	75 to 600		✓		Forward (D > 50%), Act-Clamp Fwd/Flyback	1 MHz	8.5 to 14.5	✓	✓	2/2, 2/2	20-TSSOP, 16-SOIC	1.50
UCC25600	200 W to 1 kW				Half-Bridge	350 kHz	11.5 to 18		✓	0.4/0.8	8-SOIC	0.80
UCC28950	200 W to 2 kW	✓	✓	✓	Φ-Shifted FB	1 MHz	8 to 17		✓	—	24-TSSOP	4.25
UC3875/6/7	200 W to 2 kW	✓	✓	✓	Act-Clamp Fwd/Flyback, Φ-Shifted FB	1+ MHz	10.7 to 20		✓	Four at 2/2	20-SOIC-W/DIL (PDIP), 28-PLCC	4.85
UC3879	200 W to 2 kW	✓	✓		Φ-Shifted FB	500 kHz	11 to 20		✓	Four at 0.1/0.1	20-SOIC-W/DIL (PDIP), 28-PLCC	3.70
UCC3895	200 W to 2 kW	✓	✓	✓	Φ-Shifted FB	1 MHz	11 to 17		✓	Four at 0.1/0.1	20-SOIC-W/DIL (PDIP)/PLCC	4.35
<b>Secondary-Side, Post Regulation</b>												
LM(2)5115/A	—		✓		Synchronous Secondary-Side Post Regulator	1 MHz	4.5 to 42/75		✓	2/2.5	16-TSSOP/QFN	1.35/1.80
UCC3583	50 to 500					500 kHz	8.5 to 15		✓	0.5/1.5	14-SOIC/DIL (PDIP), 20-PLCC	1.75
<b>Green Mode PWM Controllers</b>												
<b>UCC28710/1</b>	Up to 25		✓		Flyback	130 kHz	9 to 35	✓	✓	0.025/2	7-SOIC, 6-SOT-23	0.42
UCC28700/1/2/3	Up to 30		✓		Flyback	130 kHz	9 to 35		✓	0.025/2	6-SOT-26	0.35
UCC28610	10 to 40		✓		Buck, Flyback (SEPIC, Cuk)	140 kHz	9 to 20			—	8-SOIC	0.60
LM5023	5 to 100		✓		Quasi-Resonant Mode Flyback	130 kHz	8 to 15		✓	0.3/0.7	8-MSOP	0.38
UCC28600	50 to 150		✓		Flyback (SEPIC, Cuk)	130 kHz	30		✓	1/0.75	8-SOIC	0.49

<sup>1</sup>UC2xxx and UCC2xxx devices are extended temperature-range versions of the UC3xxx and UCC3xxx devices.

<sup>2</sup>Continuous On-Time architecture.

<sup>3</sup>Value varies by part number suffix. Please check datasheet.  
\*Suggested resale price in U.S. dollars in quantities of 1,000.

New devices are listed in **bold red**.  
Preview devices are listed in **bold teal**.

# AC/DC and Isolated DC/DC Power Supplies

## Gate Drivers

### Design Factors

**Supply Voltage Range** — With internal voltage regulators, MOSFET drivers can operate over a wide input voltage range, making them flexible for many applications.

**Number of Outputs** — Single and dual drivers are available to complement DC/DC switching and motor control applications.

**Output Configuration** — Inverting, non-inverting, AND and NAND configurations are available.

New single-channel low-side drivers offer split outputs (for independent source and sink to allow optimization of switch timing) and asymmetrical drive (higher sink than source current) for faster transition through Miller Plateau.

### High-Side/Low-Side Bridge Driver Portfolio

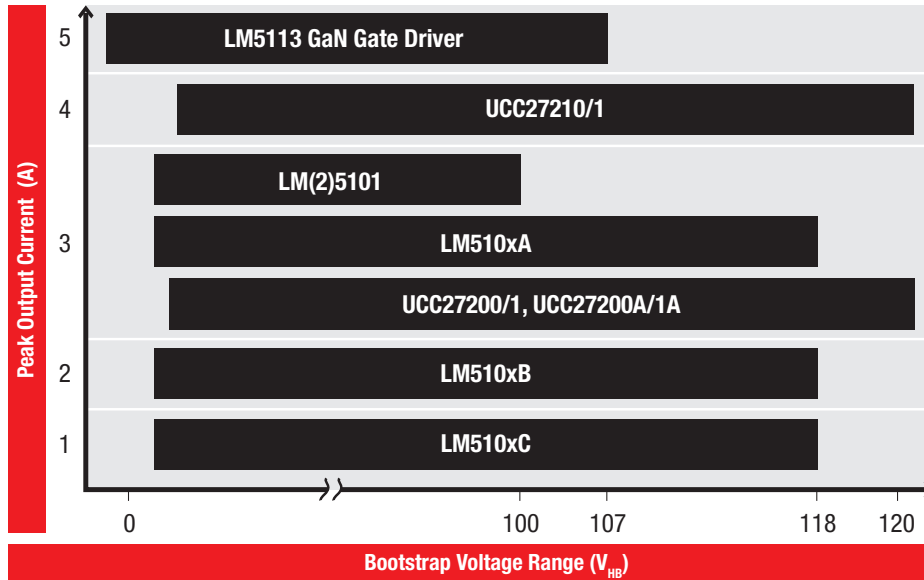

### Product Highlights

**LM5113**

- Industry's only 100-V driver for enhancement-mode GaN FETs

**UCC2721x**

- 4-A next generation of popular UCC2720x has 120-V boot voltage, -10-V input-voltage capability and ESD enhancements

**LM510xx Family**

- Drive capability scales with power-converter requirements

**LM(2)5101 Family**

- 80-V input, low power consumption, motor-control and automotive applications

### Low-Side Gate Driver Portfolio

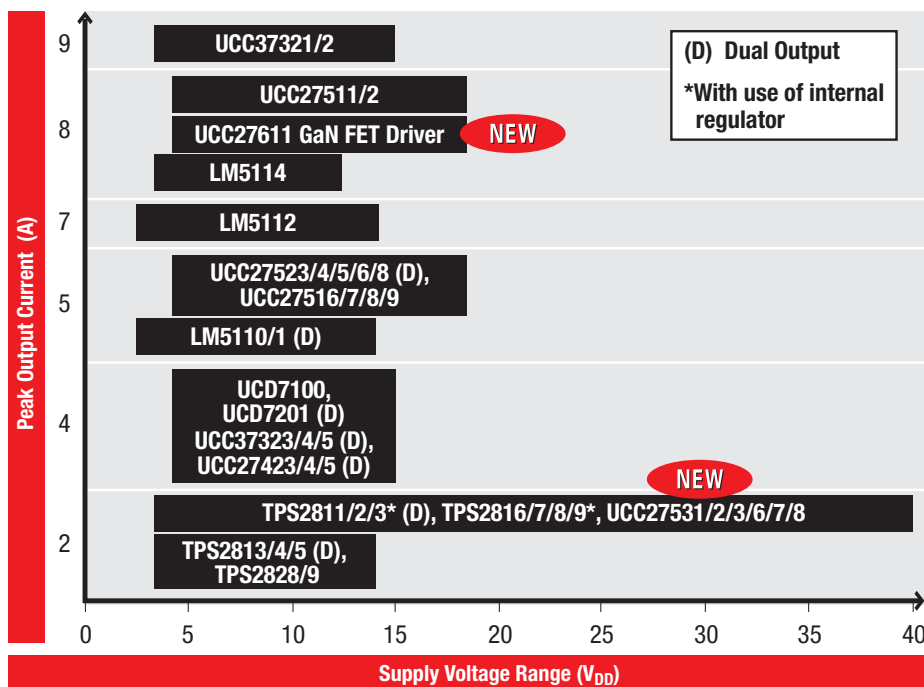

### Product Highlights

**UCC27611**

- High-speed 5-V GaN FET driver

**UCC27531**

- FET and IGBT single-gate drivers
- 2.5 A and 5 A, 35-V maximum V<sub>DD</sub>

**UCC2751x/52x**

- Asymmetrical drive and split output options available on select single-channel drivers
- Best-in-class propagation delay and higher V<sub>DD</sub> compatibility with IGBT power switches
- UCC27528 features CMOS input thresholds

**LM5114**

- Next-generation 7.6-A, 12-ns single-channel MOS and GaN FET-compatible driver

# AC/DC and Isolated DC/DC Power Supplies

## Gate Drivers

### 100-V Half-Bridge Gate Driver for Enhancement-Mode GaN FETs

#### LM5113

Enhancement mode Gallium Nitride (GaN) power FETs can provide significant power-density benefits over silicon MOSFETs in power converters. They have a much lower figure of merit (FOM) due to lower  $R_{DS(on)}$  and lower  $Q_g$ . With greater efficiencies, faster switching frequencies and an ultra-small package footprint, GaN FETs enable higher-density power converters. However, realizing these benefits does present a new set of challenges. Large source-drain voltages and the stringent gate-source voltage-drive requirements of GaN power FETs pose new challenges related to limiting the high-side FET drive level to less than 6 V, as well as preventing high  $dV/dt$  transients from causing erratic switching behavior.

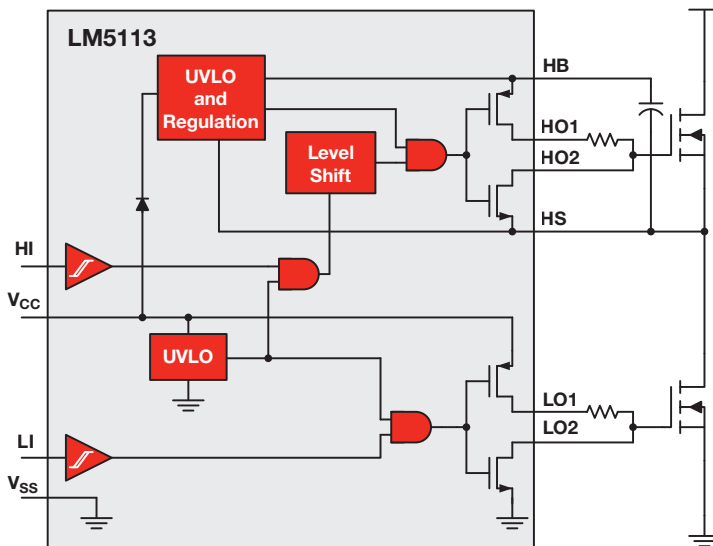

LM5113 block diagram.

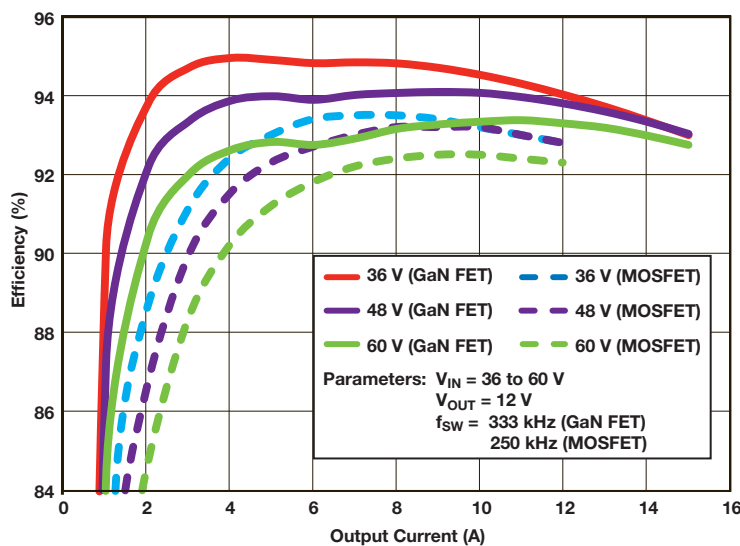

GaN FET efficiency vs traditional MOSFET.

Get more information: [www.ti.com/product/LM5113](http://www.ti.com/product/LM5113)

#### Key Features

- Independent high and low TTL logic inputs
- 1.2-A/5-A peak source/sink current
- High-side floating bias voltage rail operates up to 100 V
- Internal bootstrap supply-voltage clamping
- Split outputs for adjustable turn-on/turn-off strength
- 0.5-Ω/2-Ω pull-down/pull-up resistance
- Fast propagation times—30 ns typical

#### Applications

- Current fed push-pull converters
- Half and full-bridge converters
- Synchronous buck converters
- Two-switch forward converters
- Forward with active clamp converters

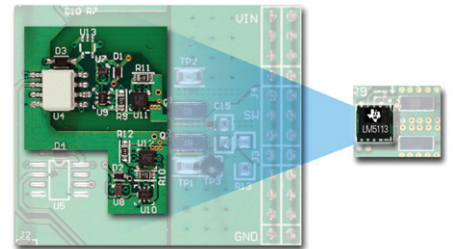

Discrete driver solution and integrated LM5113 driver. The LM5113 delivers tremendous efficiency and PCB area savings compared to discrete implementations.

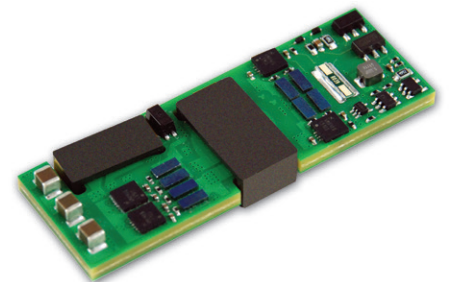

1/8 power brick featuring the EPC2001 eGaN FET and LM5113 GaN FET driver.

# AC/DC and Isolated DC/DC Power Supplies

## Gate Drivers

### Selection Guide

Device	No. of Channels	Output Configuration	Output Type <sup>1</sup>	Peak I <sub>OUT</sub> Source/Sink (A)	Rise/Fall Time (ns)	V <sub>CC</sub> Range (V)	Prop Delay (ns)	Input Threshold	Enable	Dead Time Control	Protection Features <sup>2</sup>	Internal Regulator	Price*
<b>General-Purpose Low-Side Drivers</b>													
TPS2811	2	Inverting	TrueDrive™	2/2	25/25	4 to 40	40	CMOS	—	—	—	✓	0.90
TPS2812	2	Non-inverting	TrueDrive	2/2	25/25	4 to 40	40	CMOS	—	—	—	✓	0.90
TPS2813	2	See Note 3	TrueDrive	2/2	25/25	4 to 14	40	CMOS	—	—	—	✓	0.90
TPS2814	2	Dual 2-input AND; one inverting	TrueDrive	2/2	25/25	4 to 14	40	CMOS	—	—	—	—	0.90
TPS2815	2	2-input NAND	TrueDrive	2/2	25/25	4 to 14	40	CMOS	✓	—	—	—	0.90
TPS2816	1	Inverting	TrueDrive	2/2	25/25	4 to 40	40	CMOS	—	—	—	✓	0.65
TPS2817	1	Non-inverting	TrueDrive	2/2	25/25	4 to 40	40	CMOS	—	—	—	✓	0.65
TPS2818	1	Inverting	TrueDrive	2/2	25/25	4 to 40	40	CMOS	—	—	—	✓	0.65
TPS2819	1	Non-inverting	TrueDrive	2/2	25/25	4 to 40	40	CMOS	—	—	—	✓	0.65
TPS2828	1	Inverting	TrueDrive	2/2	25/25	4 to 14	40	CMOS	—	—	—	—	0.60
TPS2829	1	Non-inverting	TrueDrive	2/2	25/25	4 to 14	40	CMOS	—	—	—	—	0.60
UC3714	2	Non-inverting	Bipolar	0.5/1	30/25	7 to 20	50	TTL/PWM	✓	Adj.	—	—	0.95
UC3715	2	See Note 3	Bipolar	1/2	30/25	7 to 20	50	TTL/PWM	✓	Adj.	—	—	0.90
UCC27323	2	Inverting	TrueDrive	4/4	25/25	4 to 15	35	TTL/CMOS	—	—	—	—	0.65
UCC27324	2	Non-inverting	TrueDrive	4/4	25/25	4 to 15	35	TTL/CMOS	—	—	—	—	0.65
UCC27325	2	See Note 3	TrueDrive	4/4	25/25	4 to 15	35	TTL/CMOS	—	—	—	—	0.65
UCC27423	2	Inverting	TrueDrive	4/4	25/25	4 to 15	35	TTL/CMOS	✓	—	—	—	0.70
UCC27424	2	Non-inverting	TrueDrive	4/4	25/25	4 to 15	35	TTL/CMOS	✓	—	—	—	0.70
UCC27425	2	See Note 3	TrueDrive	4/4	25/25	4 to 15	35	TTL/CMOS	✓	—	—	—	0.70
UCC37321	1	Inverting	TrueDrive	9/9	20/20	4 to 15	30	TTL/CMOS	✓	—	—	—	0.99
UCC37322	1	Non-inverting	TrueDrive	9/9	20/20	4 to 15	30	TTL/CMOS	✓	—	—	—	0.99
LM5114A/B	1	Non-inverting	Split	1.3/7.6	8/3.2	4 to 12.6	—	TTL/CMOS	—	—	—	—	0.60
<b>LM5134</b>	2	Non-inverting with Pilot output	Split	4.5/7.6 0.66/0.82	5.3/4.7	4 to 12.6	12	TTL/CMOS	—	—	—	—	0.60
UCC27511	1	Non-inverting	Split	4/8	9/9	4.5 to 18	14	Dual input TTL	—	—	—	—	0.60
UCC27512	1	Non-inverting	—	4/8	9/7	4.5 to 18	14	Dual input TTL	—	—	—	—	0.60
UCC27516	1	See Note 3	—	4/4	9/7	4.5 to 18	14	TTL	—	—	—	—	0.49
UCC27517	1	See Note 3	—	4/4	9/7	4.5 to 18	14	TTL	—	—	—	—	0.49
UCC27518	1	Inverting	—	4/4	9/7	4.5 to 18	14	CMOS	—	—	—	—	0.49
UCC27519	1	Non-inverting	—	4/4	9/7	4.5 to 18	14	CMOS	—	—	—	—	0.49
LM5110	2	Non-inverting	Split	5/2	14/12	3.5 to 15	25	TTL	—	—	✓	—	0.65
LM5111	2	Non-inverting	Split	5/3	14/12	3.5 to 15	25	TTL	—	—	✓	—	0.65
LM5112	2	Non-inverting	Split	7/3	14/12	3.5 to 15	25	CMOS	—	—	✓	—	0.50
UCC27523	2	Inverting	—	5/5	9/7	4.5 to 18	14	TTL	✓	—	—	—	0.75
UCC27524	2	Non-inverting	—	5/5	9/7	4.5 to 18	14	TTL	✓	—	—	—	0.75
UCC27525	2	See Note 3	—	5/5	9/7	4.5 to 18	14	TTL	✓	—	—	—	0.75
UCC27526	2	See Note 3	—	5/5	9/7	4.5 to 18	14	TTL	✓	—	—	—	0.75
<b>UCC27531</b>	1	Non-Inverting	—	-2.5/5	15/7	—	17	TTL	—	—	—	—	0.75
<b>UCC27532</b>	1	Non-Inverting	—	-2.5/5	15/7	—	17	CMOS	—	—	—	—	0.75
<b>UCC27533</b>	1	See Note 3	—	-2.5/5	15/8	—	15	TTL	—	—	—	—	0.75
<b>UCC27536</b>	1	Inverting	—	-2.5/5	15/8	—	15	TTL	—	—	—	—	0.75
<b>UCC27537</b>	1	Non-Inverting	—	-2.5/5	15/8	—	15	TTL	—	—	—	—	0.75
<b>UCC27538</b>	2	Non-Inverting	—	-2.5/5	15/8	—	15	TTL	—	—	—	—	0.75
<b>UCC27611</b>	1	See Note 3	—	-4/8	5/5	—	14	TTL	—	—	—	—	0.85
UCD7100PWP	1	Uncommitted/Non-inverting	TrueDrive	4/4	10/10	4.5 to 16	20	CMOS/TTL	—	Adaptive	—	—	0.99
UCD7201PWP	2	Uncommitted/Non-inverting	TrueDrive	4/4	10/10	4.5 to 16	20	CMOS/TTL	—	Adaptive	—	—	1.20

<sup>1</sup> Output type: TrueDrive is the hybrid bipolar/CMOS output architecture for improved current drive capability at low voltages (at Miller threshold).

<sup>2</sup> OVPC = overvoltage protection crowbar, UVLO = undervoltage lockout.

<sup>3</sup> One inverting, one non-inverting.

<sup>4</sup> Predictive Gate Drive™.

<sup>5</sup> Maximum boot voltage at HS pin.

\*Suggested resale price in U.S. dollars in quantities of 1,000.

New devices are listed in bold red.

# AC/DC and Isolated DC/DC Power Supplies

## Gate Drivers

### Selection Guide (Continued)

Device	No. of Channels	Output Configuration	Output Type <sup>1</sup>	Peak I <sub>OUT</sub> Source/Sink (A)	Rise/Fall Time (ns)	V <sub>CC</sub> Range (V)	Prop Delay (ns)	Input Threshold	Enable	Dead Time Control	Protection Features <sup>2</sup>	Internal Regulator	Price*
<b>Synchronous-Rectifier Drivers</b>													
UCC24610		Non-inverting	—	3/3	30/25	4.5 to 5.5	44	CMOS/TTL	✓	Adaptive	✓	—	0.75
<b>Synchronous Buck Drivers</b>													
TPS28225	2	Non-inverting	CMOS	2/4	10/10	4.5 to 8.8	14	TTL/CMOS	✓	Adaptive	UVLO	—	0.60
TPS28226	2	Non-inverting	CMOS	2/4	10/10	4.5 to 8.8	14	TTL/CMOS	✓	Adaptive	UVLO	—	0.60
TPS2830	2	Non-inverting	TrueDrive	2.4/2.4	50/50	4.5 to 15	75	CMOS	✓	Adaptive	OVPC	—	1.05
TPS2831	2	Inverting	TrueDrive	2.4/2.4	50/50	4.5 to 15	75	CMOS	✓	Adaptive	OVPC	—	1.05
TPS2832	2	Non-inverting	TrueDrive	2.4/2.4	50/50	4.5 to 15	75	CMOS	—	Adaptive	—	—	1.00
TPS2833	2	Inverting	TrueDrive	2.4/2.4	50/50	4.5 to 15	75	CMOS	—	Adaptive	—	—	1.00
TPS2834	2	Non-inverting	TrueDrive	2.4/2.4	30/30	4.5 to 15	70	TTL	✓	Adaptive	OVPC	—	1.05
TPS2835	2	Inverting	TrueDrive	2.4/2.4	30/30	4.5 to 15	70	TTL	✓	Adaptive	OVPC	—	1.05
TPS2836	2	Non-inverting	TrueDrive	2.4/2.4	30/30	4.5 to 15	70	TTL	—	Adaptive	—	—	1.25
TPS2837	2	Inverting	TrueDrive	2.4/2.4	30/30	4.5 to 15	70	TTL	—	Adaptive	—	—	1.25
TPS2838	2	Non-inverting	TrueDrive	4/4	120	10 to 15	40	TTL	✓	Adaptive	—	✓	1.30
TPS2839	2	Inverting	TrueDrive	4/4	120	10 to 15	40	TTL	✓	Adaptive	—	✓	1.30
TPS2848	2	Non-inverting	TrueDrive	4/4	120	10 to 15	20	TTL	✓	Adaptive	—	✓	1.25
TPS2849	2	Inverting	TrueDrive	4/4	120	10 to 15	20	TTL	✓	Adaptive	—	✓	1.25
UCC27221	2	Inverting	TrueDrive	3.3/3.3	20/20	3.7 to 20	82/103	TTL	—	PGD <sup>4</sup>	—	✓	1.70
UCC27222	2	Non-inverting	TrueDrive	3.3/3.3	20/20	3.7 to 20	82/103	TTL	—	PGD <sup>4</sup>	—	✓	1.70
UCC27223	2	Non-inverting	TrueDrive	3.3/3.3	25/35	4.15 to 20	82/103	TTL	✓	PGD <sup>4</sup>	—	✓	1.70
UCD7230	2	Non-inverting	CMOS	4/4	10/10	4.5 to 15.5	25	CMOS/TTL	—	Adaptive	Adjustable	—	0.80
<b>High-Side Low-Side Drivers—Half Bridge, Full Bridge</b>													
UCC27200/A	2	Non-inverting	TrueDrive	3/3	8/7	to 110 <sup>5</sup>	20	CMOS	—	—	UVLO	—	1.30
<b>LM25101A/B/C</b>	2	Non-inverting	CMOS	3/3	8/8	to 80	25	TTL	—	—	UVLO	—	0.49
LM5100A/B/C	2	Non-inverting	CMOS	3/3	8/8	to 118	25	CMOS	—	—	UVLO	—	1.25
UCC27201/A	2	Non-inverting	TrueDrive	3/3	8/7	to 110 <sup>5</sup>	20	TTL	—	—	UVLO	—	1.30
LM5101A/B/C	2	Non-inverting	CMOS	3/3	8/8	to 118	25	TTL	—	—	UVLO	—	1.25
UCC27210	2	Non-inverting	—	4/4	12/9	to 115 <sup>5</sup>	20	CMOS	—	—	UVLO	—	1.40
UCC27211	2	Non-inverting	—	4/4	12/9	to 115 <sup>5</sup>	20	TTL	—	—	UVLO	—	1.40
LM5113	2	Non-inverting	GaN FET	1.2/5	4/4	to 100 <sup>5</sup>	30	TTL	—	—	UVLO	—	1.65

<sup>1</sup> Output type: TrueDrive is the hybrid bipolar/CMOS output architecture for improved current drive capability at low voltages (at Miller threshold).

<sup>2</sup> OVPC = overvoltage protection crowbar, UVLO = undervoltage lockout.

<sup>3</sup> One inverting, one non-inverting.

<sup>4</sup> Predictive Gate Drive™.

<sup>5</sup> Maximum boot voltage at HS pin.

\*Suggested resale price in U.S. dollars in quantities of 1,000.

New devices are listed in bold red.

# Power Modules (Non-Isolated)

## Overview

Design with TI's comprehensive power module portfolio for wide input-voltage and output-current ranges, flexible packaging options and easy-to-use integrated solutions for a variety of non-isolated, industrial, medical, and communications applications.

### SIMPLE SWITCHER® Power Modules

Easy-to-use modules for applications requiring high input voltages (up to 42 V).

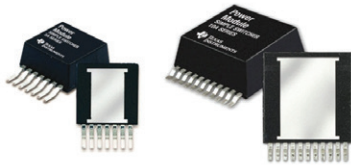

#### Power Modules

- Leaded PMOD package
- Single exposed bottom
- Supports 5-V, 12-V and 24-V rails
- Output currents of up to 10 A

#### Nano Modules

- Miniature form factor
- Adjustable output
- Output current of up to 1 A
- High efficiency and low noise

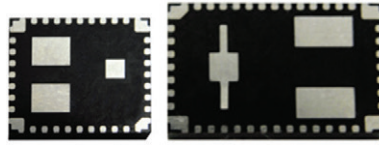
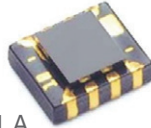

### TPS84k Power Modules

High-density devices for applications where a simple and small total solution size is desired.

- Input-voltage range: 2.95 to 50 V
- QFN packaging
- Feature-rich and flexible
- Only three external components required



### MicroSiP™ Modules: TPS81k (Boost) Family and TPS82k (Step-Down) Family

Smallest total-solution footprint.

- Integrates all required components
- Achieves 90 mA/mm<sup>2</sup>
- High efficiency over entire load range
- Supports noise-critical applications through spread-spectrum modulation

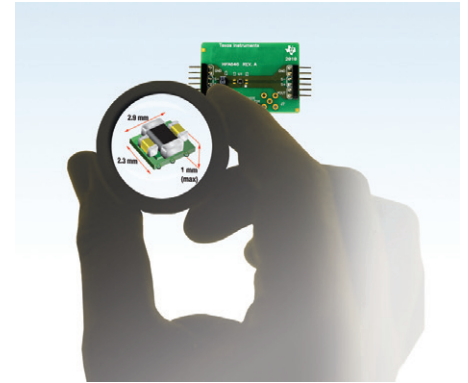

### PTH08T2xx "T2" Power Modules

High-current modules for applications that require up to 50 A.

- High output current of up to 50 A
- TurboTrans™ feature for tunable transient response
- Current sharing (50-A version)

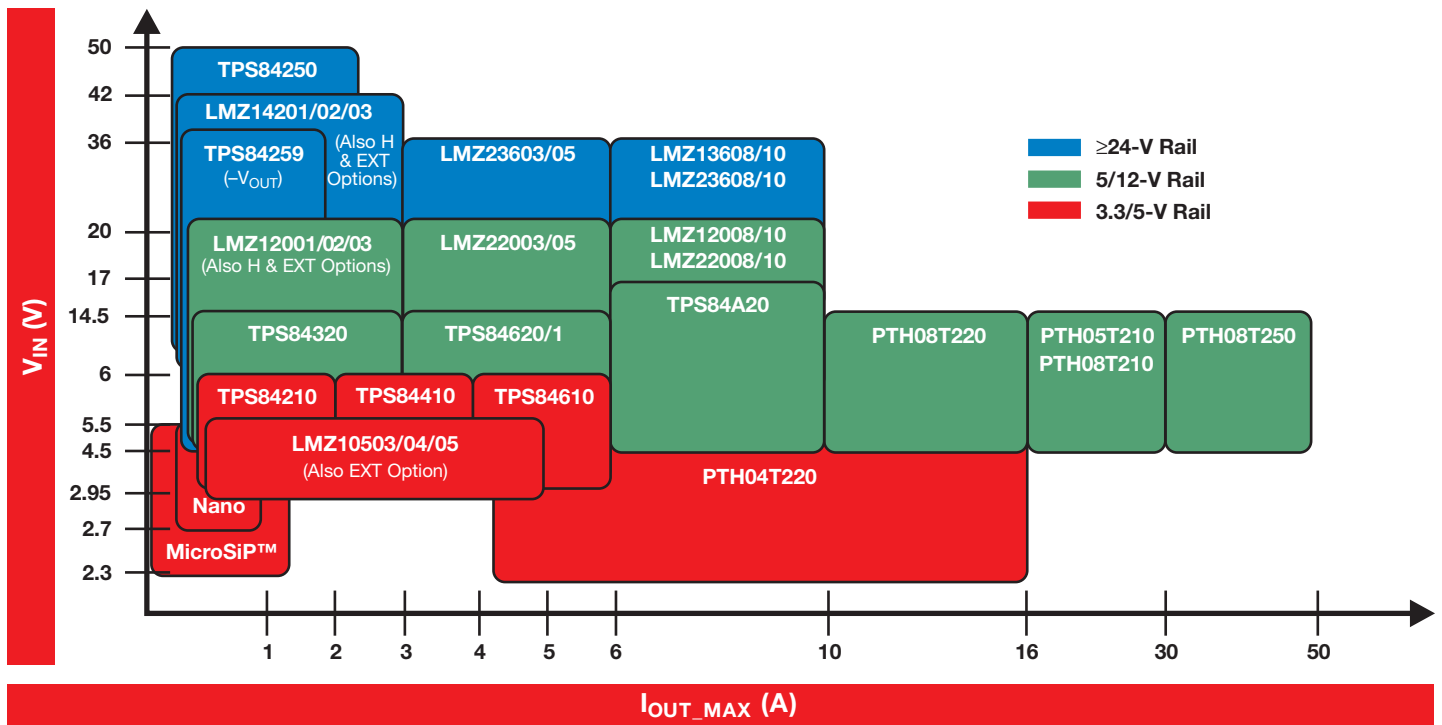

# Power Modules (Non-Isolated)

## Step-Down (Buck) Modules

### SIMPLE SWITCHER® Power Modules

The SIMPLE SWITCHER power modules allow you to design and optimize robust power supplies with a minimum set of external components. All SIMPLE SWITCHER power modules provide you with low EMI, excellent thermal performance and pin-to-pin compatibility for added design flexibility. Plus, SIMPLE SWITCHER power modules utilize WEBENCH® Power Designer online design tools, feature evaluation boards and reference designs, and include application notes and videos to make design easy.

#### Easy-to-Use Packaging

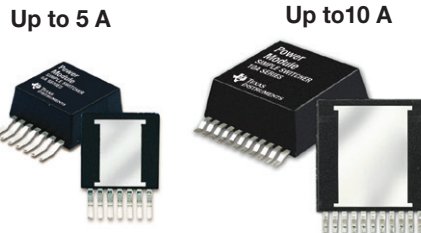

#### Key Features

- Integrated shielded inductor
- Precision enable, external soft-start, and tracking for sequencing
- Best-in-class thermal performance
- Low output voltage ripple
- Standard junction temperature grade: -40 to +125°C
- Easy-to-use package with single exposed copper bottom
- Passes EN55022 (CISPR22) Class B Radiated and Conducted EMI Standard

### SIMPLE SWITCHER® LMZ1-Series Power Modules

Device	Output Current (max) (A)	Input Voltage (V)	Adjustable Output Voltage (V)	Peak Efficiency (%)	Operating Junction Temperature (°C)	Features	EMI EN55022/CISPR22 Class B Certification		Package(s)	Price*
							Radiated	Conducted <sup>1</sup>		
LMZ10503/04/05	3/4/5	2.95 to 5.5	0.8 to 5	96	-40 to 125	EN, SS	✓	✓	TO-PMOD-7	3.95/4.50/4.95
LMZ12001/02/03	1/2/3	4.5 to 20	0.8 to 6	92	-40 to 125	EN, SS	✓	✓	TO-PMOD-7	4.46/5.10/5.95
LMZ14201/02/03	1/2/3	6 to 42	0.8 to 6	90	-40 to 125	EN, SS	✓	✓	TO-PMOD-7	6.18/7.13/8.95
LMZ12008/10	8/10	6 to 20	0.8 to 6	92	-40 to 125	EN, SS	✓	✓	TO-PMOD-11	10.93/13.30
LMZ13608/10	8/10	6 to 36	0.8 to 6	92	-40 to 125	EN, SS	✓	✓	TO-PMOD-11	15.68/17.10

<sup>1</sup>Additional input filter required.

\*Suggested resale price in U.S. dollars in quantities of 1,000.

#### High Output Voltage Power Modules

The LMZ1420xH SIMPLE SWITCHER power modules have an output voltage range from 5 to 30 V. These power modules are a good choice for intermediate rail conversions, powering fans or other types of non-traditional points of load, and for sensing applications requiring voltages below -6 V.

#### Extended Temperature (EXT) Family of Power Modules

The SIMPLE SWITCHER EXT power modules provide excellent performance in the most extreme conditions, with extended ambient temperatures guaranteed down to -55°C and shock and vibration compliant to meet military MIL-STD-883 standards.

### High Output Voltage and Extended Temperature Power Modules

Device	Output Current (max) (A)	Input Voltage (V)	Adjustable Output Voltage (V)	Peak Efficiency (%)	Operating Junction Temperature (°C)	Features	EMI EN55022/CISPR22 Class B Certification		Shock and Vibration Compliant	Package(s)	Price*
							Radiated	Conducted <sup>1</sup>			
LMZ10503/04/05EXT	3/4/5	2.95 to 5.5	0.8 to 5	96	-55 to 125	EN, SS	✓	✓	✓	TO-PMOD-7	12.60/13.50/14.40
LMZ12001/02/03EXT	1/2/3	4.5 to 20	0.8 to 6	92	-55 to 125	EN, SS	✓	✓	✓	TO-PMOD-7	9.50/11.40/13.80
LMZ14201/02/03EXT	1/2/3	6 to 42	0.8 to 6	94	-55 to 125	EN, SS	✓	✓	✓	TO-PMOD-7	12.40/14.30/17.20
LMZ14201H/02H/03H	1/2/3	6 to 42	5 to 24	97	-40 to 125	EN, SS	✓	✓		TO-PMOD-7	6.18/7.13/8.95

<sup>1</sup>Additional input filter required.

\*Suggested resale price in U.S. dollars in quantities of 1,000.

### SIMPLE SWITCHER® LMZ2-Series Power Modules

Device	Output Current (max) (A)	Input Voltage (V)	Adjustable Output Voltage (V)	Operating Junction Temperature (°C)	Features	EMI EN55022/CISPR22 Class B Certification		Package(s)	Price*
						Radiated	Conducted <sup>1</sup>		
LMZ22003/5	3/5	6 to 20	0.8 to 5	-40 to 125	EN, SS, Freq Sync	✓	✓	TO-PMOD-7	5.50/6.25
LMZ23603/5	3/5	6 to 36	0.8 to 6	-40 to 125	EN, SS, Freq Sync	✓	✓	TO-PMOD-7	9.85/12.50
LMZ22008/10	8/10	6 to 20	0.8 to 6	-40 to 125	EN, SS, Freq Sync, Current Share	✓	✓	TO-PMOD-11	11.50/14.00
LMZ23608/10	8/10	6 to 36	0.8 to 6	-40 to 125	EN, SS, Freq Sync, Current Share	✓	✓	TO-PMOD-11	16.50/18.00

<sup>1</sup>Additional input filter required.

\*Suggested resale price in U.S. dollars in quantities of 1,000.



# Power Modules (Non-Isolated)

## Step-Down (Buck) Modules

### SIMPLE SWITCHER® Nano Modules

The new SIMPLE SWITCHER nano modules combine ease of use and high performance in a tiny solution size. The nano modules boast the smallest 1-A package in the market today. It's the first integrated inductor solution with the IC mounted on the inductor to reduce board space requirements and improve performance, making them superior for space-constrained, point-of-load applications.

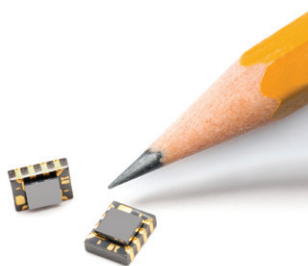

### Easy-to-Use Package

The new nano module packaging size of 2.5 x 3 x 1.2 mm, makes it the tiniest 1-A DC/DC solution in the market. By mounting the IC on a shielded inductor, the nano modules provide a complete solution that requires only an input capacitor, an output capacitor, a  $V_{CON}$  capacitor, and feedback resistors in 35 mm<sup>2</sup> of board space.

### SIMPLE SWITCHER® Nano Modules

Device	Output Current (max) (A)	Input Voltage (V)	Adjustable Output Voltage (V)	Operating Junction Temperature (°C)	Features	Frequency (kHz)	CISPR22 Class B EMI	Package Size (mm)	Price*
LMZ10500	0.65	2.7 to 5.5	0.6 to 3.6	-40 to 125	EN, SS	2000	✓	3.0 x 2.5 x 1.2	1.30
LMZ10501	1	2.7 to 5.5	0.6 to 3.6	-40 to 125	EN, SS	2000	✓	3.0 x 2.5 x 1.2	1.55

\*Suggested resale price in U.S. dollars in quantities of 1,000.

### MicroSiP™ Modules

#### 600-mA, Fully Integrated, Low-Noise Step-Down Converter

#### TPS82671

##### Key Features

- Regulated switching frequency: 5.5 MHz
- Spread spectrum (SSM), PWM frequency dithering, high PSRR and low-ripple Power Save mode
- Automatic Power Save mode transition or forced PWM mode operation
- Input voltage: 2.3 to 4.8 V

##### Applications

- Mid- to high-end cell phones, smartphones
- Portable audio/video
- Fiber optics
- Digital TV, WLAN, GPS and Bluetooth®

##### Benefits

- Allows < 7-mm<sup>2</sup> total solution size, providing 90 mA/mm<sup>2</sup>
- One-stop-shop, reduced hardware-design workload and no more questionable designs

- Allows choice between high efficiency over entire load range (Power Save mode) or regulated fixed frequency
- Supports Li-Ion batteries with extended voltage range

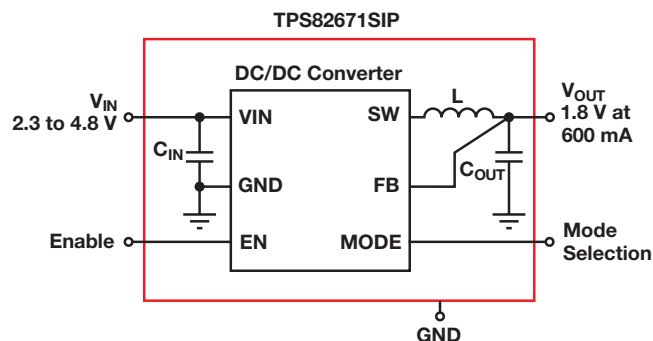
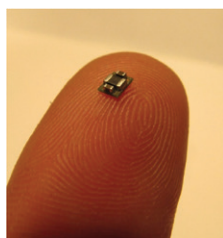

Get more information: [www.ti.com/product/TPS82671](http://www.ti.com/product/TPS82671)

### MicroSiP™ Power Modules Selection Guide

Device	Base Function	I <sub>OUT</sub> (mA)	V <sub>IN</sub> (V)	Fixed V <sub>OUT</sub> (V)	Peak Efficiency (%)	Switching Frequency (typ) (kHz)	Quiescent Current (typ) (µA)	Shutdown Current (typ) (µA)	Synchronous Rectifier	Active Output Capacitor Discharge	Total Solution Size (mm <sup>2</sup> )	MicroSiP Package	EVM	Features and Differentiators	Price*
<b>Fully Integrated Solutions (Inductor plus input/output capacitors on device)</b>															
TPS82695	Step-Down	500	2.3 to 4.35	2.85/2.5	95	4000	24	0.5	✓	✓	6.7	8	✓		1.30
TPS82671	Step-Down	600	2.3 to 4.8	1.1/1.2/1.5/1.8	90	5500	17	0.5	✓	✓	6.7	8	✓	Spread spectrum	1.30
TPS82680	Step-Down	800	2.3 to 5.5	1.0/1.8/3.3	92	6000	15	0.5	✓	✓	6.7	8	✓	Spread spectrum	TBD
TPS82660	Step-Down	1500	2.3 to 5.5	1.0/1.8/3.3	93	6000	15	0.5	✓	✓	6.7	8	✓	Spread spectrum	TBD

All of the above devices have undervoltage lockout and thermal protection built in.

\*Maximum current depends on input and output voltages.

\*Suggested resale price in U.S. dollars in quantities of 1,000.

Preview devices are listed in bold teal.

# Power Modules (Non-Isolated)

## Step-Down (Buck) Modules

### SWIFT™ Power Modules

**TPS84250, TPS84259**

**NEW**

#### Key Features

- Integrated inductor and passives require as few as three external components
- Small low-profile QFN packaging capable of 260°C reflow
- Low package thermal resistance delivers full current at  $T_a = 85^\circ\text{C}$
- Low noise: All modules meet EN55022 Class B emissions
- Wide operating temperature: Up to  $125^\circ\text{C } T_j$

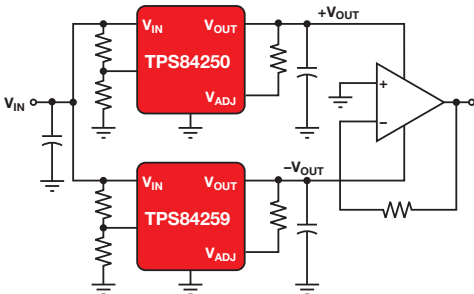

#### TPS84250 Features

- 7- to 50-V input; survives 65-V transients
- 2.5- to 15-V output up to 2.5 A
- Small 9 x 11 x 2.8-mm QFN package

#### TPS84259 Features

- 4.5- to 40-V input
- -3- to -17-V output up to 15 W
- Small 9 x 11 x 2.8-mm QFN package

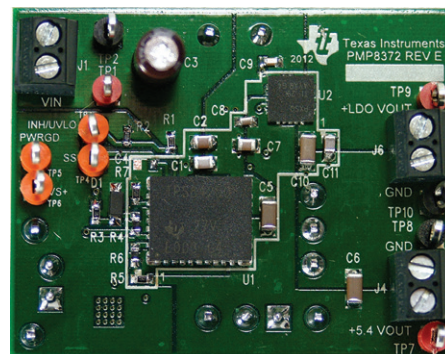

PMP8372 reference design.

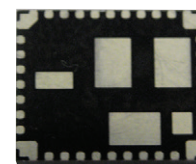
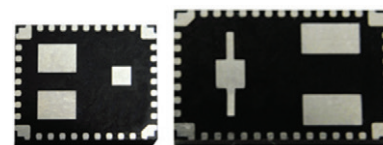
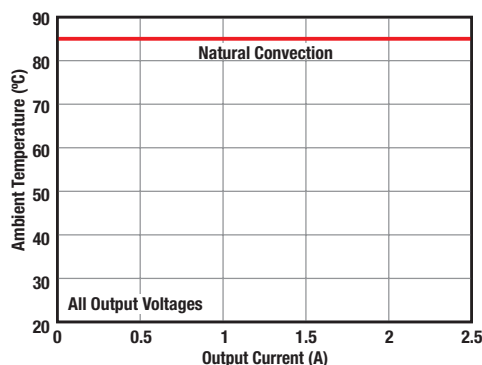

Package options.

Get more information: [www.ti.com/tps84k](http://www.ti.com/tps84k)

[www.ti.com/product/TPS84250](http://www.ti.com/product/TPS84250) or [TPS84259](http://www.ti.com/product/TPS84259)

[www.ti.com/tool/PMP8372](http://www.ti.com/tool/PMP8372)

## SWIFT™ Power Modules Selection Guide

Device	I <sub>OUT</sub> (A)	V <sub>IN</sub> (V)	V <sub>OUT</sub> (V)	Package Theta J <sub>A</sub> (°C/W)	Switching Frequency (kHz)	Features						EVM	Package(s)	Price*	
						Power Good Pin	Sync Pin	Adj. Soft Start	180° Out of Phase	Sequencing/Tracking	Current Sharing				
<b>Low Input Voltage</b>															
TPS84210	2	2.95 to 6.0	0.8 to 3.6	12	500 to 2000	✓	✓	✓		✓		✓	39 QFN (9x11x2.8 mm)	2.95	
TPS84410	4	2.95 to 6.0	0.8 to 3.6	12	500 to 2000	✓	✓	✓		✓		✓	39 QFN (9x11x2.8 mm)	3.80	
TPS84610	6	2.95 to 6.0	0.8 to 3.6	12	500 to 2000	✓	✓	✓		✓	✓	✓	39 QFN (9x11x2.8 mm)	4.15	
<b>Mid Input Voltage</b>															
TPS84320	3	4.5 to 14.5	0.8 to 5.5	13	330 to 780	✓	✓	✓		✓		✓	47 QFN (9x15x2.8 mm)	3.75	
<b>TPS84420</b>	4	2.95 to 17	0.6 to 5.5	TBD	200 to 1200	✓	✓	✓	✓		✓	✓	44 QFN (10x10x4.3 mm)	TBD	
TPS84621	6	4.5 to 14.5	0.6 to 5.5	13	250 to 780	✓	✓	✓		✓	✓	✓	47 QFN (9x15x2.8 mm)	4.15	
<b>TPS84720</b>	7	2.95 to 17	0.6 to 5.5	TBD	200 to 1200	✓	✓	✓	✓		✓	✓	44 QFN (10x10x4.3 mm)	TBD	
<b>TPS84A20</b>	10	2.95 to 17	0.6 to 5.5	TBD	200 to 1200	✓	✓	✓	✓		✓	✓	44 QFN (10x10x4.3 mm)	TBD	
<b>TPS84B20</b>	20	4.5 to 14.5	0.6 to 2.8	TBD	500/900	✓		✓			✓	✓	68 QFN (15x16x5.8 mm)	TBD	
<b>TPS84C20</b>	30	4.5 to 14.5	0.6 to 2.8	TBD	500/900	✓		✓			✓	✓	68 QFN (15x16x5.8 mm)	TBD	
<b>Wide Input Voltage</b>															
<b>TPS84250</b>	2.5	7 to 50	2.5 to 15	12	400 to 1000	✓	✓	✓		✓		✓	41 QFN (9x11x2.8 mm)	5.25	
<b>TPS84259</b>	2	4.5 to 40	-3 to -17	14	700 to 900		✓	✓				✓	41 QFN (9x11x2.8 mm)	6.00	

All of the above devices have undervoltage lockout and thermal protection built in.

\*Suggested resale price in U.S. dollars in quantities of 1,000.

New devices are listed in bold red. Preview devices are listed in bold teal.

WEBENCH® models available for all SWIFT devices: [www.ti.com/webench](http://www.ti.com/webench)

# Power Modules (Non-Isolated)

## Step-Down (Buck) Modules

### Non-Isolated Plug-In Power Modules (POLA™ and Others) Family of Products

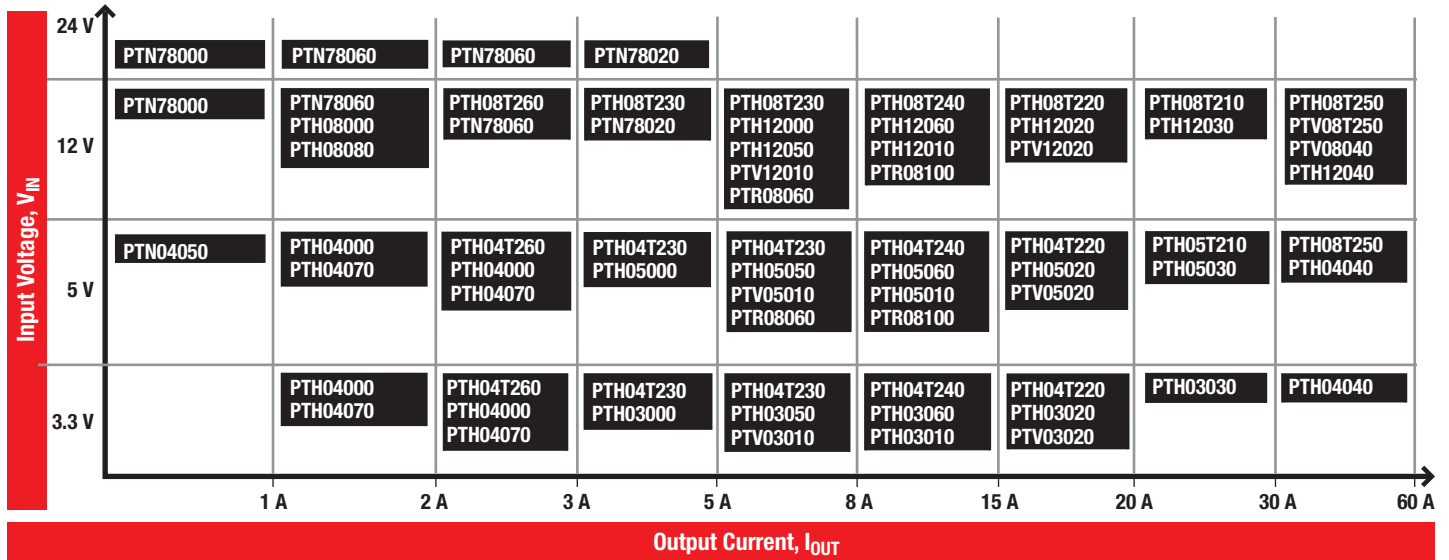

### 16-A, 4.5-V to 14-V Input, POL Module with TurboTrans™ Technology

#### PTH08T220W

The PTH08T220W is a high-performance, 16-A-rated, T2 point-of-load (POL) power module. Operating from an input voltage range of 4.5 V to 14 V, the PTH08T220W requires a single resistor to set the output voltage to any value over the range of 0.7 V to 5.5 V. The PTH08T220W incorporates TurboTrans technology, SmartSync and Auto-Track™ sequencing.

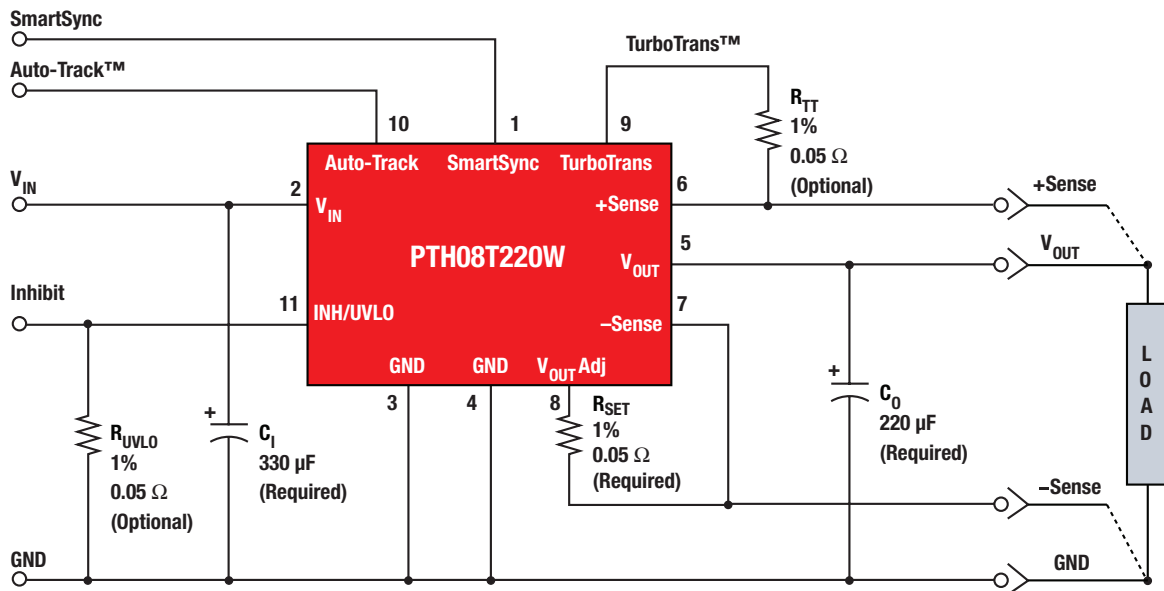

Get more information: [www.ti.com/product/PTH08T220W](http://www.ti.com/product/PTH08T220W)

# Power Modules (Non-Isolated)

## Step-Down (Buck) Modules

### Selection Guide

Device <sup>1</sup>	Input Bus Voltage	Description	P <sub>OUT</sub> or I <sub>OUT</sub>	V <sub>0</sub> Range (V)	V <sub>0</sub> Adj.	Auto-Track™ Sequencing	POLA™	DDR-QDR	Price*
<b>Non-Isolated Single Positive Output</b>									
PTH03000W	3.3 V	3.3-V Input 6-A POL	6 A	0.8 to 2.5	✓				6.90
PTH03010W	3.3 V	3.3-V Input 15-A POL with Auto-Track Sequencing	15 A	0.8 to 2.5	✓	✓	✓		11.60
PTH03020W	3.3 V	3.3-V Input 22-A POL with Auto-Track Sequencing	22 A	0.8 to 2.5	✓	✓	✓		18.15
PTH03030W	3.3 V	3.3-V Input 30-A POL with Auto-Track Sequencing	30 A	0.8 to 2.5	✓	✓	✓		25.00
PTH03050W	3.3 V	3.3-V Input 6-A POL with Auto-Track Sequencing	6 A	0.8 to 2.5	✓	✓	✓		6.90
PTH03060W	3.3 V	3.3-V Input 10-A POL with Auto-Track Sequencing	10 A	0.7 to 2.5	✓	✓	✓		9.80
PTH04000W	3.3 V/5 V	3-V to 5.5-V Input 3-A POL with Auto-Track Sequencing	3 A	0.9 to 3.6	✓	✓	✓		4.50
PTH04070W	3.3 V/5 V	3-V to 5.5-V Input 3-A POL	3 A	0.9 to 3.6	✓				4.28
PTH04040W	3.3 V/5 V	3-V to 5.5-V Input 60-A POL with Auto-Track Sequencing	60 A	0.8 to 3.6	✓	✓	✓		35.00
PTH04T220/221W	3.3 V/5 V	2.2- to 5.5-V Input, 16-A T2 2nd Gen PTH POL with TurboTrans™	16 A	0.7 to 3.6	✓	✓	✓		12.60
PTH04T230/231W	3.3 V/5 V	2.2- to 5.5-V Input, 6-A T2 2nd Gen PTH POL with TurboTrans	6 A	0.7 to 3.6	✓	✓			7.90
PTH04T240/241W	3.3 V/5 V	2.2- to 5.5-V Input, 10-A T2 2nd Gen PTH POL with TurboTrans	10 A	0.7 to 3.6	✓	✓			10.80
PTH04T260/261W	3.3 V/5 V	2.2- to 5.5-V Input, 6-A T2 2nd Gen PTH POL with TurboTrans	3 A	0.7 to 3.6	✓	✓			6.25
PTH05000W	5 V	5-V Input 6-A POL	6 A	0.8 to 3.6	✓				6.90
PTH05010W	5 V	5-V Input 15-A POL with Auto-Track Sequencing	15 A	0.8 to 3.6	✓	✓	✓		11.60
PTH05020W	5 V	5-V Input 22-A POL with Auto-Track Sequencing	22 A	0.8 to 3.6	✓	✓	✓		18.15
PTH05030W	5 V	5-V Input 30-A POL with Auto-Track Sequencing	30 A	0.8 to 3.6	✓	✓	✓		25.00
PTH05050W	5 V	5-V Input 6-A POL with Auto-Track Sequencing	6 A	0.8 to 3.6	✓	✓	✓		6.90
PTH05060W	5 V	5-V Input 10-A POL with Auto-Track Sequencing	10 A	0.8 to 3.6	✓	✓	✓		9.80
PTH05T210W	5 V	5-V Input, 30-A T2 2nd Gen PTH POL with TurboTrans	30 A	0.7 to 3.6	✓	✓	✓		18.00
PTH08000W	5 V/12 V	4.5-V to 18-V Input, 2.25-A POL with Auto-Track Sequencing	2.25 A	0.9 to 5.5	✓	✓	✓		4.50
PTH08080W	5 V/12 V	4.5-V to 18-V Input, 2.25-A POL	2.25 A	0.9 to 5.5	✓				4.28
PTH08T210W	12 V	5.5- to 14-V Input, 30-A T2 2nd Gen PTH POL with TurboTrans	30 A	0.7 to 3.6	✓	✓	✓		18.00
PTH08T220/221W	5 V/12 V	4.5- to 14-V Input, 16-A T2 2nd Gen PTH POL with TurboTrans	16 A	0.7 to 5.5	✓	✓	✓		12.60
PTH08T230/231W	5 V/12 V	4.5- to 14-V Input, 6-A T2 2nd Gen PTH POL with TurboTrans	6 A	0.7 to 5.5	✓	✓			7.90
PTH08T240/241W	5 V/12 V	4.5- to 14-V Input, 10-A T2 2nd Gen PTH POL with TurboTrans	10 A	0.7 to 5.5	✓	✓			10.80
PTH08T240F	5 V/12 V	4.5- to 14-V Input, 10-A T2 2nd Gen PTH POL for 3-GHz DSP Systems	10 A	0.7 to 2.0	✓	✓			10.80
PTH08T250/255W	5 V/12 V	4.5- to 14-V Input, 50-A T2 2nd Gen PTH POL with TurboTrans	50 A	0.7 to 5.5	✓	✓			36.00
PTH08T260/261W	5 V/12 V	4.5- to 14-V Input, 3-A T2 2nd Gen PTH POL with TurboTrans	3 A	0.7 to 5.5	✓	✓			6.25
PTH12000L/W	12 V	12-V Input 6-A POL	6 A	0.8 to 1.8/1.2 to 5.5	✓				6.90
PTH12010L/W	12 V	12-V Input 12-A POL with Auto-Track Sequencing	12 A	0.8 to 1.8/1.2 to 5.5	✓	✓	✓		11.60
PTH12020L/W	12 V	12-V Input 18-A POL with Auto-Track Sequencing	18 A	0.8 to 1.8/1.2 to 5.5	✓	✓	✓		18.15
PTH12030L/W	12 V	12-V Input 26-A POL with Auto-Track Sequencing	26 A	0.8 to 1.8/1.2 to 5.5	✓	✓	✓		25.00
PTH12040W	12 V	12-V Input 50-A POL with Auto-Track Sequencing	50 A	0.8 to 5.5	✓	✓	✓		35.00
PTH12050L/W	12 V	12-V Input 6-A POL with Auto-Track Sequencing	6 A	0.8 to 1.8/1.2 to 5.5	✓	✓	✓		6.90
PTH12060L/W	12 V	12-V Input 10-A POL with Auto-Track Sequencing	10 A	0.8 to 1.8/1.2 to 5.5	✓	✓	✓		9.80
PTH03010Y	3.3 V	3.3-V Input 15-A DDR Terminating Module	15 A	Follows V <sub>REF</sub>	✓		✓	✓	11.60
PTH03050Y	3.3 V	3.3-V Input 6-A DDR Terminating Module	6 A	Follows V <sub>REF</sub>	✓		✓	✓	6.90
PTH03060Y	3.3 V	3.3-V Input 10-A DDR Terminating Module	10 A	Follows V <sub>REF</sub>	✓		✓	✓	9.80
PTH05010Y	5 V	5-V Input 15-A DDR Terminating Module	15 A	Follows V <sub>REF</sub>	✓		✓	✓	11.60
PTH05050Y	5 V	5-V Input 6-A DDR Terminating Module	6 A	Follows V <sub>REF</sub>	✓		✓	✓	6.90
PTH05060Y	5 V	5-V Input 10-A DDR Terminating Module	10 A	Follows V <sub>REF</sub>	✓		✓	✓	9.80
PTH12010Y	12 V	12-V Input 12-A DDR Terminating Module	12 A	Follows V <sub>REF</sub>	✓		✓	✓	11.60
PTH12050Y	12 V	12-V Input 6-A DDR Terminating Module	6 A	Follows V <sub>REF</sub>	✓		✓	✓	6.90
PTH12060Y	12 V	12-V Input 8-A DDR Terminating Module	8 A	Follows V <sub>REF</sub>	✓		✓	✓	9.80
PTN04050C	3.3 V/5 V	3-V/5-V Input, 12-W Output Step-Up (Boost) ISR	12 W	5 to 15	✓				8.00
PTN78000W/H	V <sub>0</sub> + 2 to 36 V	Wide-Input, Wide-Output 1.5-A Positive Step-Down ISR	1.5 A	2.5 to 12/12 to 22	✓				8.00
PTN78060W/H	V <sub>0</sub> + 2 to 36 V	Wide-Input, Wide-Output 3-A Positive Step-Down ISR	3 A	2.5 to 12/12 to 22	✓				11.00
PTN78020W/H	V <sub>0</sub> + 2 to 36 V	Wide-Input, Wide-Output 6-A Positive Step-Down ISR	6 A	2.5 to 12/12 to 22	✓				15.00
PTR08060W	5 V/12 V	4.5- to 14-V Input, 6-A POL	6 A	0.6 to 5.5	✓				6.00
PTR08100W	5 V/12 V	4.5- to 14-V Input, 10-A POL	10 A	0.6 to 5.5	✓				8.00
PTV03010W	3.3 V	5-V Input 8-A Vertical SIP with Auto-Track Sequencing	8 A	0.8 to 2.5	✓	✓	✓		6.90
PTV03020W	3.3 V	5-V Input 18-A Vertical SIP with Auto-Track Sequencing	18 A	0.8 to 2.5	✓	✓	✓		11.60
PTV05010W	5 V	5-V Input 8-A Vertical SIP with Auto-Track Sequencing	8 A	0.8 to 3.6	✓	✓	✓		6.90
PTV05020W	5 V	5-V Input 18-A Vertical SIP with Auto-Track Sequencing	18 A	0.8 to 3.6	✓	✓	✓		11.60
PTV08T250W	12 V	8-V to 14-V Input, 50-A T2 2nd Gen PTH POL with TurboTrans	50 A	0.8 to 3.6	✓	✓			36.00
PTV12010L/W	12 V	12-V Input 8-A Vertical SIP with Auto-Track Sequencing	8 A	0.8 to 1.8/1.2 to 5.5	✓	✓	✓		6.90
PTV12020L/W	12 V	12-V Input 18-A Vertical SIP with Auto-Track Sequencing	16 A	0.8 to 1.8/1.2 to 5.5	✓	✓	✓		11.60

<sup>1</sup>See [www.ti.com/power](http://www.ti.com/power) for a complete product offering.

\*Suggested resale price in U.S. dollars in quantities of 1,000.

# Power Modules (Non-Isolated)

## Step-Up (Boost) and Negative Output Modules

### 3-W, High-Efficiency Step-Up Converter

**NEW**

#### TPS81256

The TPS81256 MicroSiP™ converter is a 3-W boost converter that integrates the inductor and input/output capacitors to achieve a solution less than 9 mm<sup>2</sup> and sub-1 mm high, simplifying design and saving up to 50% more board space than competing solutions. The 4-MHz, 600-mA TPS81256 module supports a 5-V output with a power density of 400 mW/mm<sup>3</sup>. The device extends battery life by reducing the supply current to 43 μA during light-load operation. Over a Li-Ion battery's full voltage range of 2.5 to 5.5 V, the TPS81256 also achieves a power efficiency of up to 91% that enables it to efficiently manage 3 W in a module format of less than 9 cubic millimeters.

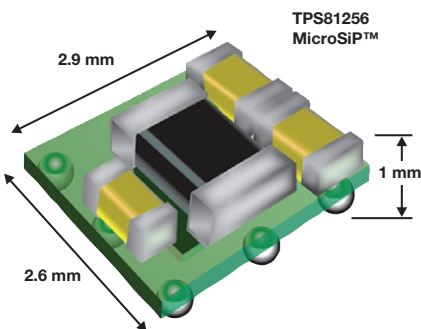
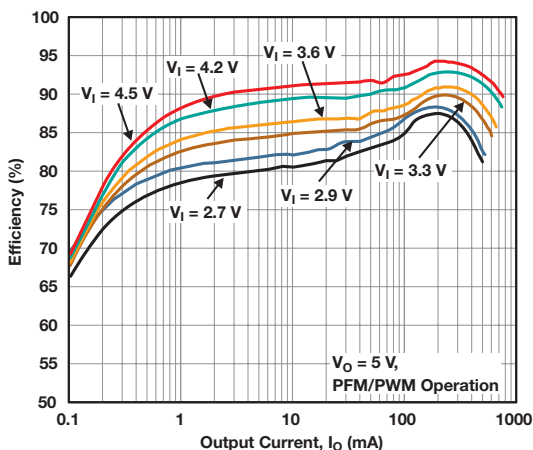

3-W boost converter integrated solution.

#### Key Features

- Smallest solution size: Achieves a solution less than 9 mm<sup>2</sup> and sub-1 mm high, providing a power density of 400 mW/mm<sup>3</sup>
- Simplifies design: High integration, including passives and capacitors, significantly reduces the effort required for hardware design and layout
- High performance: Up to 91% peak efficiency, and high efficiency over a wide load range

#### Applications

- Cell phones, smartphones, tablet PCs
- Powering mono and stereo APA
- Powering USB-OTG, HDMI
- USB charging port (5 V)

Get more information: [www.ti.com/product/TPS81256](http://www.ti.com/product/TPS81256)

### MicroSiP™ Boost Power Module

Device	Base Function	I <sub>OUT</sub> (mA)	V <sub>IN</sub> (V)	Fixed V <sub>OUT</sub> (V)	Peak Efficiency (%)	Switching Frequency (typ) (kHz)	Quiescent Current (typ) (μA)	Shutdown Current (typ) (μA)	Synchronous Rectifier	Active Output Capacitor Discharge	Total Solution Size (mm <sup>2</sup> )	MicroSiP Package	EVM	Features and Differentiators	Price*
<b>Fully Integrated Solutions (Inductor plus input/output capacitors on device)</b>															
<b>TPS81256</b>	Boost	600	2.5 to 5.5	5	95	4000	37	0.85	✓		9	9	✓	True load disconnect	1.70

All of the above devices have undervoltage lockout and thermal protection built in.  
\*Suggested resale price in U.S. dollars in quantities of 1,000.

New devices are listed in bold red.

### Negative Output Modules

Device	Input Bus Voltage	Description	P <sub>OUT</sub> or I <sub>OUT</sub>	V <sub>O</sub> Range (V)	V <sub>O</sub> Adj.	Price*
PTN04050A	3.3 V/5 V	3-V to 5-V Input, 6-W Positive to Negative (Buck-Boost) ISR	6 W	-3.3 to -15	✓	8.00
PTN78000A	7 to 29 V	Wide-Input, Wide-Output 1.5-A Positive to Negative (Buck-Boost) ISR	1.5 A	-3 to -15	✓	8.00
PTN78060A	9 to 29 V	Wide-Input, Wide-Output 15-W Positive to Negative (Buck-Boost) ISR	15 W	-3 to -15	✓	11.00
PTN78020A	9 to 29 V	Wide-Input, Wide-Output 25-W Positive to Negative (Buck-Boost) ISR	25 W	-3 to -15	✓	15.00

\*Suggested resale price in U.S. dollars in quantities of 1,000.

Device	I <sub>OUT</sub> (A)	V <sub>IN</sub> (V)	V <sub>OUT</sub> (V)	Package Theta J <sub>A</sub> (°C/W)	Switching Frequency (kHz)	Features		EVM	Package(s)	Price*
						Sync Pin	Adj. Soft Start			
<b>SWIFT™ Wide Input Power Module</b>										
<b>TPS84259</b>	2 <sup>1</sup>	4.5 to 40	-3 to -17	12	500/800	✓	✓	✓	41 QFN (9x11x2.8 mm)	6.00

All of the above devices have undervoltage lockout and thermal protection built in.

<sup>1</sup>Maximum current depends on input and output voltages.

\*Suggested resale price in U.S. dollars in quantities of 1,000.

New devices are listed in bold red.

# DC/DC Switching Regulators

## Overview

TI's large portfolio of non-isolated DC/DC point-of-load solutions address size, efficiency, performance or cost constraints. Our solutions range from discrete devices to integrated power solutions that contain magnetics within the IC package. Visit [www.ti.com/power](http://www.ti.com/power) to find the latest point-of-load solutions by simply providing the voltages and output current of your system.

**Step-Down DC/DC Converters** — Integrated MOSFET technology has reached high levels of density over the past few years to provide higher efficiency in smaller packages. TI's DC/DC converters offer many compelling solutions up to 30 A.

**Power-Management Units (PMUs)** — Multiple DC/DC converters in one package simplify the power design by

reducing component count. TI's PMUs integrate several inductive step-down converters with linear regulators, charge pumps or other analog circuits such as battery chargers and an I<sup>2</sup>C interface to save space.

**Step-Up Boost Converters** — The datasheet specifies the current limit of the integrated power MOSFET switches. A rough estimate for the actual output current achievable is a function of the duty cycle and can be estimated with the following formula:

$$I_{OUT} = 0.65 \times I_{Switch(min)} \times (V_{IN}/V_{OUT})$$

**Buck-Boost Converters** — A DC/DC converter must be able to regulate the output voltage at all possible input-voltage conditions, whether  $V_{IN}$  is higher or lower than  $V_{OUT}$ . TI's single-inductor buck-boost converters integrate four

power MOSFETs on-chip to save space and to seamlessly transition in between the modes of operation.

**Charge Pumps** — TI's family of low-voltage charge pumps provides a low-noise solution to boost the voltage without an inductor. Charge pumps achieve 90% peak efficiency and are useful for output currents under 300 mA.

**DC/DC Controllers** — The output current is set by external MOSFETs, which allows the designer to optimize the efficiency and performance. Strong MOSFET drivers in TI's controllers can drive more external MOSFETs.

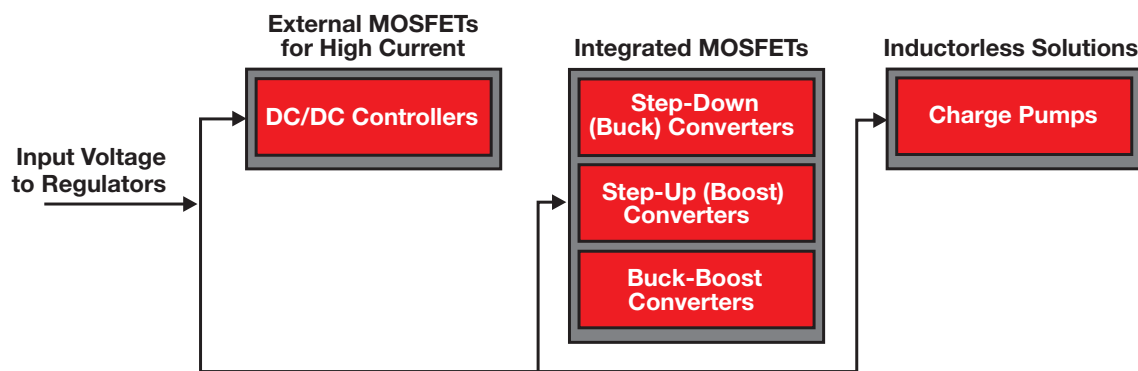

# DC/DC Switching Regulators

## Step-Down Converters (Line and Portable Power)

### SWIFT™ High Power-Density Converters

TI's SWIFT DC/DC converters are switchers with integrated FETs that deliver a high power density, high efficient and high-performance point-of-load power supply. Whether powering a performance processor or advanced analog circuitry, SWIFT DC/DC converters help solve board-space and power-budget challenges. High-frequency operation and low MOSFET on-resistance in a small package allow designers to reduce board space without sacrificing efficiency.

Learn more at [www.ti.com/swift](http://www.ti.com/swift)

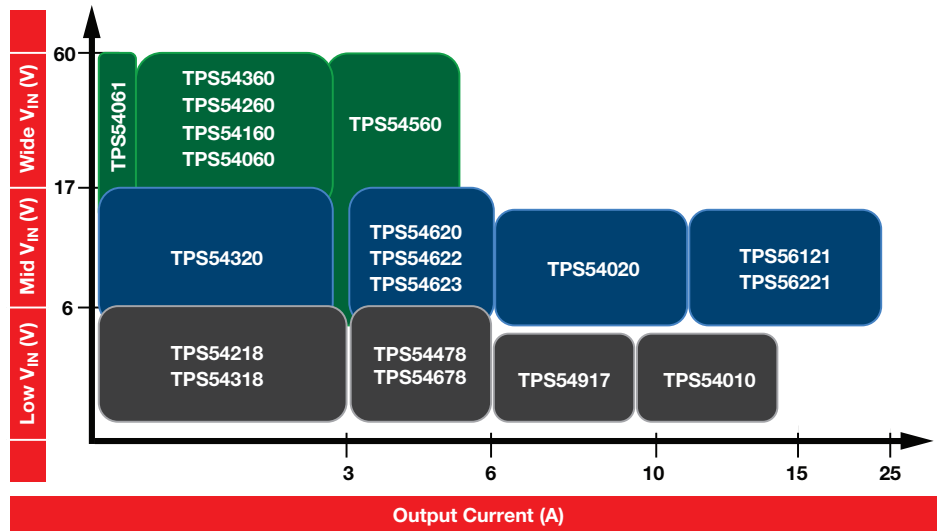

### Highest Power Density SWIFT™ Converter: 10 A, 17 V in HotRod™ QFN package with Eco-mode™

#### TPS54020

**NEW**

The TPS54020 is a 10-A synchronous step-down DC/DC converter in a small 3.5 x 3.5-mm HotRod 15-pad QFN package. The TPS54020 integrates low  $R_{DS(on)}$  MOSFETs. Eco-mode operation is automatically engaged at light loads to save energy. The TPS54020 SWIFT converter has selectable current-limit trip points to optimize inductor size and is supported by TI's WEBENCH® Designer tool.

#### Key Features

- Low-resistance, 8-mΩ high-side MOSFET
- Low-resistance, 6-mΩ low-side MOSFET
- Selectable hiccup or cycle-by-cycle current-limit scheme
- Selectable 6-A, 8-A or 10-A current-limit trip point
- 180° out-of-phase switching
- 0.6-V ref with 1% accuracy over temp
- 200-kHz to 1.2-MHz adjustable switching frequency

#### Applications

- Power for FPGAs, SoCs DSPs and processors
- Wireless, data and cloud infrastructure
- Gaming, DTV and set top boxes

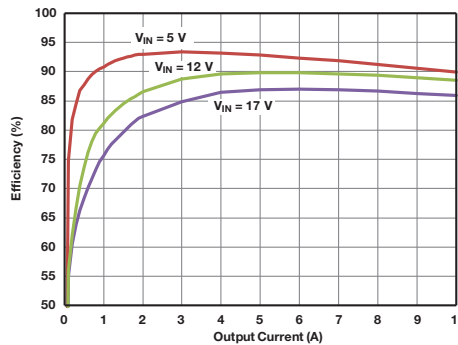
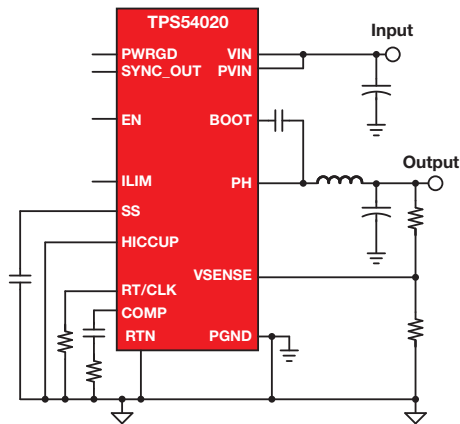

Get more information: [www.ti.com/product/TPS54020](http://www.ti.com/product/TPS54020)

# DC/DC Switching Regulators

## Step-Down Converters (Line and Portable Power)

### Synchronous Step-Down Converters with < 25-V Maximum Input

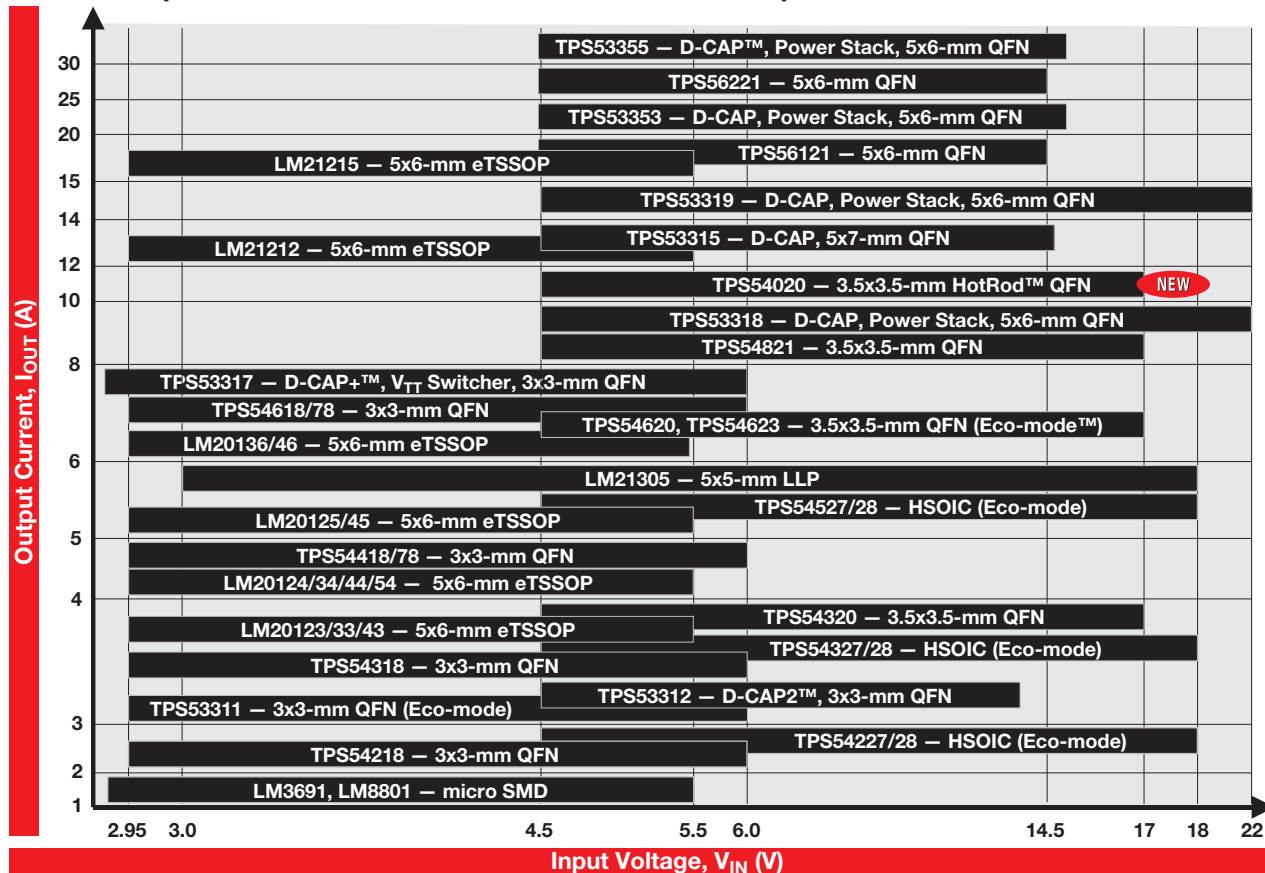

### Step-Down Converters with > 25-V Maximum Input

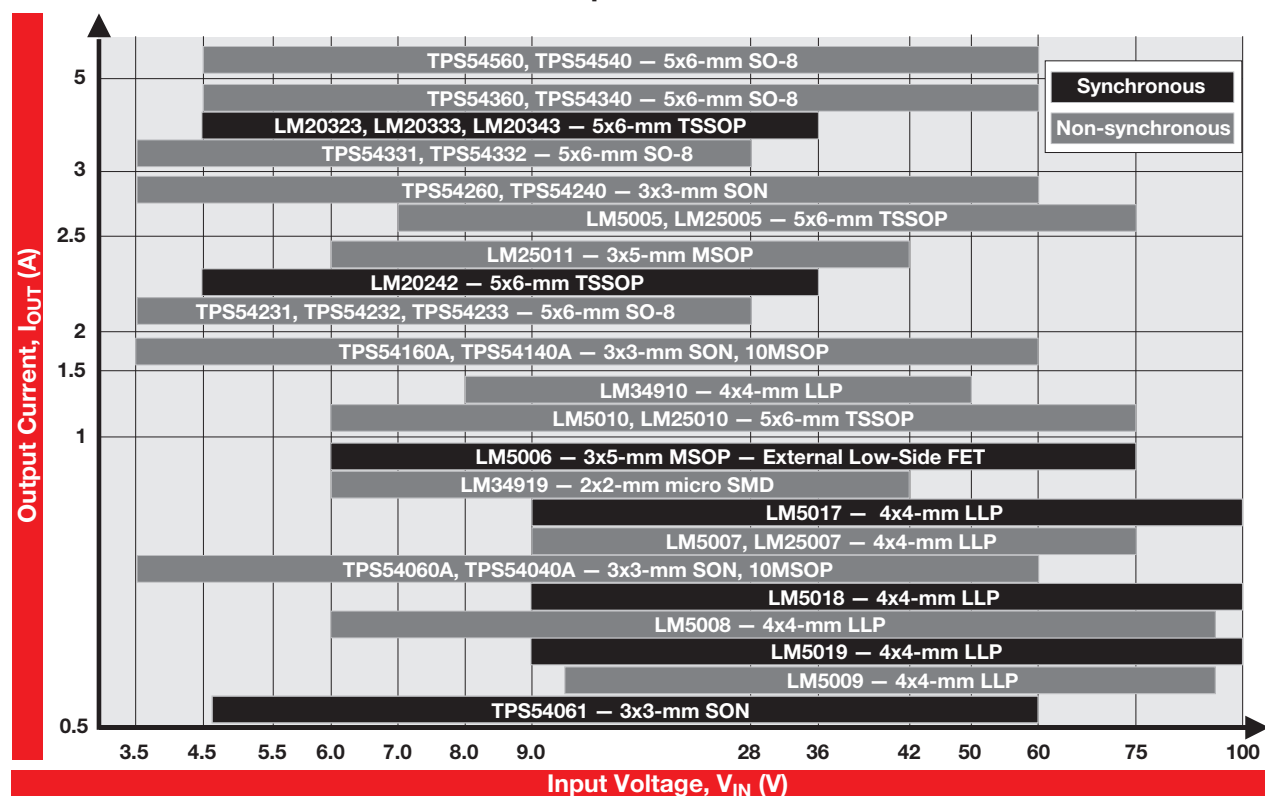



# DC/DC Switching Regulators

## Step-Down Converters (Line and Portable Power)

### 100-V Buck Regulator Enhances Reliability for High-Voltage Applications

#### LM5017

TI's family of high-voltage converters is characterized by a constant-on-time (COT) architecture that reduces the number of required external components to keep solution sizes small and simplify designs. The new LM5017 100-V, 600-mA synchronous buck regulator is the first in a family of the industry's first 100-V converters with integrated high-side and low-side FETs. Continuous conduction mode operation allows for use as a small, isolated bias supply.

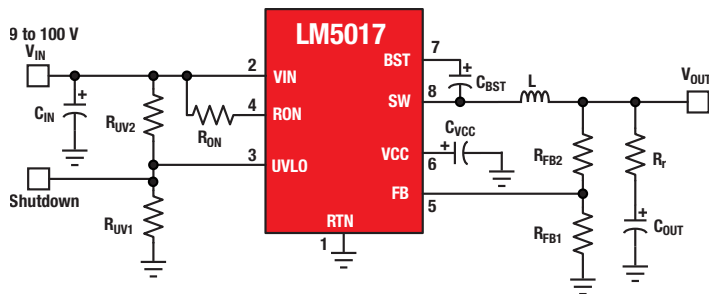

#### Key Features

- Wide 9- to 100-V input-voltage range
- Integrated, 100-V high- and low-side switches
- Fast transient response
- Frequency adjustable to 1 MHz
- Constant-on-time architecture requires no loop compensation

#### Applications

- Telecommunication systems
- Automotive electronics
- Isolated bias supply
- Smart power meters

Reference designs available at [www.ti.com/tool/pmp7315](http://www.ti.com/tool/pmp7315) and [www.ti.com/tool/pmp7316](http://www.ti.com/tool/pmp7316)

Get more information: [www.ti.com/product/LM5017](http://www.ti.com/product/LM5017)

### Selection Guide for Line Power

Device	I <sub>OUT</sub> (mA)	V <sub>IN</sub> (V)	Min V <sub>OUT</sub> (V)	Max Duty Cycle (%)	Switching Frequency (kHz)	Features							EVM	Package(s)	Price*
						Synchronous Rectifier	Power Good Pin	Sync Pin	180° Out-of-Phase Switching	Adj. Soft Start	Light-Load Efficiency	External Compensation			
<b>Low Input Voltage Step-Down Converters (&lt;6 V<sub>IN</sub>)</b>															
TPS54218	2000	2.95 to 6.0	0.8	98	200 to 2000	✓	✓	✓		✓		✓	✓	16 QFN (3x3 mm)	1.50
LM20123/33/43	3000	2.95 to 5.5	0.8	—	250 to 1500	✓	✓	✓		✓		✓	✓	16 eTSSOP	1.36
TPS54318	3000	2.95 to 6.0	0.8	98	200 to 2000	✓	✓	✓		✓		✓	✓	16 QFN (3x3 mm)	2.00
TPS53311	3000	2.9 to 6.0 <sup>1</sup>	0.6	85	1000	✓		✓			✓	✓	✓	16 QFN (3x3 mm)	2.15
LM20124/34/44/54	4000	2.95 to 5.5	0.8	—	250 to 1500	✓	✓	✓		✓		✓	✓	16 eTSSOP	1.50
TPS54418/78	4000	2.95 to 6.0	0.8/0.6	98	200 to 2000	✓	✓	✓		✓		✓	✓	16 QFN (3x3 mm)	2.35
LM20125/45	5000	2.95 to 5.5	0.8	—	250 to 1500	✓	✓			✓		✓	✓	16 eTSSOP	1.56
TPS53316	5000	2.95 to 6	0.6	80	750/1100/2000	✓	✓				✓	✓	✓	16 QFN (3x3 mm)	2.55
LM20136/46	6000	2.95 to 5.5	0.8	—	250 to 1500	✓	✓	✓		✓		✓	✓	16 eTSSOP	1.68
TPS54618/78	6000	2.95 to 6.0	0.8/0.6	98	200 to 2000	✓	✓	✓		✓		✓	✓	16 QFN (3x3 mm)	2.85
LM21212-1	12000	2.95 to 5.5	0.6	100	300 to 1500	✓	✓	✓		✓		✓	✓	20 eTSSOP	3.30
LM21212-2	12000	2.95 to 5.5	0.6	100	300 to 1500	✓	✓			✓		✓	✓	20 eTSSOP	3.30
LM21215	Up to 15000	2.95 to 5.5	0.6	100	500	✓	✓			✓		✓	✓	20 eTSSOP	3.55
LM21215A	15000	2.95 to 5.5	0.6	100	300 to 1500	✓	✓	✓		✓		✓	✓	20 eTSSOP	3.55
<b>Mid Input Voltage Step-Down Converters (&lt;20 V<sub>IN</sub>)</b>															
TPS62170	500	3.0 to 17	0.9	100	2250	✓	✓				✓		✓	8 QFN (2x2 mm)	0.75
TPS62150	1000	3.0 to 17	0.9	100	2250	✓	✓			✓	✓		✓	16 QFN (3x3 mm)	1.00
TPS54227/8	2000	4.5 to 18	0.76	90 <sup>2</sup>	700	✓				✓	-✓		✓	8 HSOIC	1.10/1.15
TPS54320	3000	4.5 to 17	0.8	98	200 to 1200	✓	✓	✓		✓		✓	✓	14 QFN	1.70
TPS54327/8	3000	4.5 to 18	0.76	90 <sup>2</sup>	700	✓				✓	-✓		✓	8 HSOIC	1.20/1.25
TPS54427/8	4000	4.5 to 18	0.76	90 <sup>2</sup>	700					✓	-✓		✓	8 HSOIC	1.30/1.35
LM21305	5000	3 to 18	0.6	100	250 to 1500		✓	✓		✓	✓	✓	✓	28 LLP	2.50
TPS54527/8	5000	4.5 to 18	0.76	90 <sup>2</sup>	700					✓	-✓		✓	8 HSOIC	1.70/1.75
TPS53313	6000	4.5 to 16	0.6	70	250 to 1500		✓	✓		✓		✓	✓	16 QFN (4x4 mm)	2.60

<sup>1</sup>Requires 2.9- to 3.5-V bias input.

<sup>4</sup>Maximum V<sub>OUT</sub> is 5.5 V.

<sup>2</sup>Maximum V<sub>OUT</sub> is 5.5 V.

<sup>5</sup>Requires 4.5- to 25-V bias input.

<sup>3</sup>Maximum V<sub>OUT</sub> is 5.5 V.

\*Suggested resale price in U.S. dollars in quantities of 1,000.

New devices are listed in bold red. Preview devices are listed in bold teal.

# DC/DC Switching Regulators

## Step-Down Converters (Line and Portable Power)

### Selection Guide for Line Power (Continued)

Device	I <sub>OUT</sub> (mA)	V <sub>IN</sub> (V)	Min V <sub>OUT</sub> (V)	Max Duty Cycle (%)	Switching Frequency (kHz)	Features							EVM	Package(s)	Price*
						Synchronous Rectifier	Power Good Pin	Sync Pin	180° Out-of-Phase Switching	Adj. Soft Start	Light-Load Efficiency	External Compensation			
<b>Mid Input Voltage Step-Down Converters (&lt;20 V<sub>IN</sub>) (Continued)</b>															
TPS54620	6000	4.5 to 17	0.8	98	200 to 1600	✓	✓	✓		✓		✓	✓	QFN (3.5x3.5 mm)	2.50
TPS54623	6000	4.5 to 17	0.6	98	200 to 1600	✓	✓	✓		✓		✓	✓	QFN (3.5x3.5 mm)	2.55
TPS54821	8000	4.5 to 17	0.6	98	200 to 1600	✓	✓	✓		✓		✓	✓	QFN (3.5x3.5 mm)	2.75
<b>TPS54020</b>	10000	4.5 to 17	0.6	98	200 to 1200	✓	✓	✓	✓	✓		✓	✓	HotRod™ QFN (3.5x3.5 mm)	3.45
TPS51315	10000	3 to 14 <sup>3</sup>	0.76	100 <sup>4</sup>	100 to 1000	✓	✓			✓		✓	✓	QFN (5x7 mm)	2.65
TPS56121	15000	4.5 to 14	0.6	93	300/500/1000	✓	✓			✓		✓	✓	22 QFN (5x6 mm)	5.25
TPS56221	25000	4.5 to 14	0.6	93	300/500/1000	✓	✓			✓		✓	✓	22 QFN (5x6 mm)	4.35
TPS53355	30000	3 to 15 <sup>5</sup>	0.6	90 <sup>4</sup>	250 to 1000		✓			✓		✓	✓	22 QFN (5x6 mm)	4.65
<b>High Input Voltage Step-Down Converters (&gt;20 V<sub>IN</sub>)</b>															
TPS54062	50	4.7 to 60	0.8	98	100 to 400	✓		✓				✓	✓	8 MSOP	1.10
LM5019	100	9 to 100	1.23	—	250 to 1000								✓	8 LLP, 8 PSOP	1.25
LM5009/A	150	8/6 to 95	—	—	50 to 600								✓	8 LLP, 8 MSOP	1.00/1.10
<b>TPS54061</b>	200	4.7 to 60	0.8	98	50 to 1100	✓		✓		✓	✓	✓	✓	8 SON (3x3 mm)	1.30
LM5018	300	9 to 100	1.23	—	—								✓	8 LLP, 8 PSOP	1.40
LM5008/A	350	8/6 to 95	—	—	50 to 600								✓	8 LLP, 8 MSOP	1.18/1.20
TPS62175	500	4.75 to 28	1.0	100	1000		✓			✓			✓	10 QFN (2x3 mm)	0.95
LM(2)5007	500	9 to 42/75	2.5	—	50 to 800								✓	8 LLP, 8 MSOP	1.05/1.30
TPS54040A/60A	500	3.5 to 42/60	0.8	98	100 to 2500		✓	✓		✓	✓	✓	✓	10 MSOP, 10 SON (3x3mm)	1.15/1.45
LM5017	600	9 to 100	1.23	—	250 to 1000								✓	8 LLP, 8 PSOP	1.65
LM34919/B	600	8/6 to 40	2.5	—	Up to 2600					✓			✓	10 micro SMD	1.20/1.25
LM5006	650	6 to 75	2.5	—	50 to 600								✓	10 MSOP	1.50
LM(2)5010/A	1000	8/6 to 42/75	2.5	—	50 to 1000					✓			✓	10 LLP, 14 eTSSOP	1.15/1.53
TPS5410	1000	5.5 to 36	1.23	87	500								✓	8 SOIC	1.60
LM34917A	1250	8 to 33	2.5	—	2000					✓				12 micro SMD	1.35
LM34910/C	1250	8 to 36/50	2.5	—	1000					✓				10 LLP	1.32
LM26001	1500	3 to 38	1.25	—	150 to 500		✓	✓	✓		✓	✓	✓	16 TSSOP	2.85
TPS54140A/60A	1500	3.5 to 42/60	0.8	98	100 to 2500		✓	✓		✓	✓	✓	✓	10 MSOP, 10 SON (3x3mm)	1.40/1.75
LM25011/A	Up to 2000	6 to 42	2.5	—	Up to 2000		✓			✓			✓	10 MSOP	1.30
LM20242	2000	4.5 to 36	0.8	—	1000		✓			✓		✓	✓	16 eTSSOP	1.46
TPS5420	2000	5.5 to 36	1.23	87	500								✓	8 SOIC	1.70
TPS54231/2/3	2000	3.5 to 28	0.8	93	570/1000/300					✓	✓	✓	✓	8 SOIC	1.25
LM(2)5005	2500	7 to 42/75	1.23	—	50 to 500			✓		✓		✓	✓	20 eTSSOP	1.95
TPS54240/60	2500	3.5 to 42/60	0.8	98	100 to 2500		✓	✓		✓	✓	✓	✓	10 MSOP, 10 SON (3x3mm)	1.55/1.95
LM26003	3000	3 to 38	1.25	—	150 to 500		✓	✓	✓		✓	✓	✓	20 eTSSOP	3.52
LM20323/33/43	3000	4.5 to 36	0.8	—	250 to 1500		✓	✓		✓		✓	✓	20 eTSSOP	1.50
TPS5430	3000	5.5 to 36	1.23	87	500								✓	8 HSOIC	1.85
TPS54331	3000	3.5 to 28	0.8	93	570					✓	✓	✓	✓	8 SOIC	1.35
TPS54332	3500	3.5 to 28	0.8	93	1000					✓	✓	✓	✓	8 HSOIC	1.40
<b>TPS54340/60</b>	3500	4.5 to 42/60	0.8	98	100 to 2500	✓				✓	✓	✓	✓	8 HSOIC	1.75/2.10
TPS5450	5000	5.5 to 36	1.23	87	500								✓	8 HSOIC	2.25
<b>TPS54540/60</b>	5000	4.5 to 42/60	0.8	98	100 to 2500	✓				✓	✓	✓	✓	8 HSOIC	1.95/2.30
<b>Dual-Channel Step-Down Converters</b>															
TPS54290/1/2	1500/2500	4.5 to 18	0.8	90	300/600/1200	✓			✓				✓	16 HTSSOP	2.95
TPS54294/5	2000 each	4.5 to 18	0.76	85	700	✓	✓/-			-/✓			✓	16 HTSSOP	2.40
TPS54283/6	2000 each	4.5 to 28	0.8	90/85	300/600				✓				✓	14 HTSSOP	2.40
TPS55383/6	3000 each	4.5 to 28	0.8	90/85	300/600				✓				✓	16 HTSSOP	2.65
TPS54494/5	4000/2000	4.5 to 18	0.76	85	700	✓	✓/-			-/✓			✓	16 HTSSOP	2.90

<sup>1</sup>Requires 2.9- to 3.5-V bias input.

<sup>4</sup>Maximum V<sub>OUT</sub> is 5.5 V.

<sup>2</sup>Maximum V<sub>OUT</sub> is 5.5 V.

<sup>5</sup>Requires 4.5- to 25-V bias input.

<sup>3</sup>Maximum V<sub>OUT</sub> is 5.5 V.

\*Suggested resale price in U.S. dollars in quantities of 1,000.

New devices are listed in bold red.  
Preview devices are listed in bold teal.

# DC/DC Switching Regulators

## Step-Down Converters (Line and Portable Power)

### SIMPLE SWITCHER® Step-Down (Buck) Nano Regulators

The new SIMPLE SWITCHER nano regulators feature tiny packaging, 1-MHz or greater switching frequency for extremely small surface mount inductors and chip capacitors, and a minimal BOM to reduce board space. All nano regulators are offered in either LLP, SOT-23, or micro SMD packaging for added design flexibility.

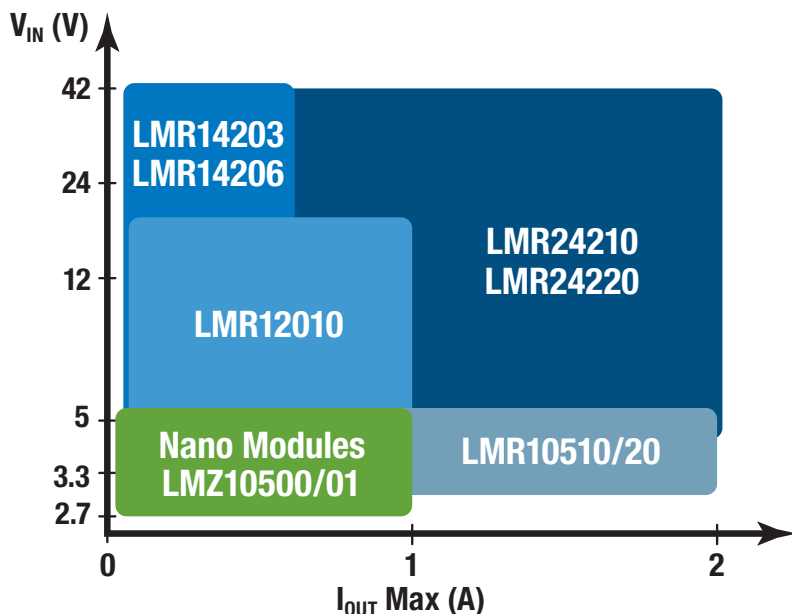

### SIMPLE SWITCHER® Step-Down (Buck) Nano Regulators

Device	Output Current (max) (A)	Input Voltage (V)	Adjustable Output Voltage (V)	Frequency (kHz)	Features	Package(s)	Price*
<b>Nano Step-Down (Buck)</b>							
LMR10510	1	3 to 5.5	0.6 to 4.5	1600, 3000	EN, SS	LLP-6, SOT-23	0.30
LMR10515	1.5	3 to 5.5	0.6 to 4.5	1600, 3000	EN, SS	LLP-6, SOT-23	0.85
LMR10520	2	3 to 5.5	0.6 to 4.5	1600, 3000	EN, SS	LLP-6	0.38
LMR12010	1	3 to 20	0.8 to 16	1600, 3000	EN, SS	TSOT-23	0.79
LMR14203	0.3	4.5 to 42	0.765 to 34	1250	EN, SS	TSOT-23	0.90
LMR14206	0.6	4.5 to 42	0.765 to 34	1250	EN, SS	TSOT-23	1.01
LMR24210	1	4.5 to 42	0.8 to 24	1000 max	EN, SS	micro SMD-28	1.50
LMR24220	2	4.5 to 42	0.8 to 24	1000 max	EN, SS	micro SMD-28	2.00

\*Suggested resale price in U.S. dollars in quantities of 1,000.

# DC/DC Switching Regulators

## Step-Down Converters (Line and Portable Power)

### SIMPLE SWITCHER® Converters

National's award-winning SIMPLE SWITCHER products allow you to design and optimize robust power supplies with a minimum set of external components. Supporting input voltage ranges of 3 to 75 V, each SIMPLE SWITCHER series provides you with multiple products with pin-to-pin compatibility for added design flexibility. Plus, all SIMPLE SWITCHER products utilize the WEBENCH® Power Designer end-to-end design and prototyping tools.

For more information, please visit:  
[www.ti.com/switcher](http://www.ti.com/switcher)

### SIMPLE SWITCHER® Step-Down (Buck) Family

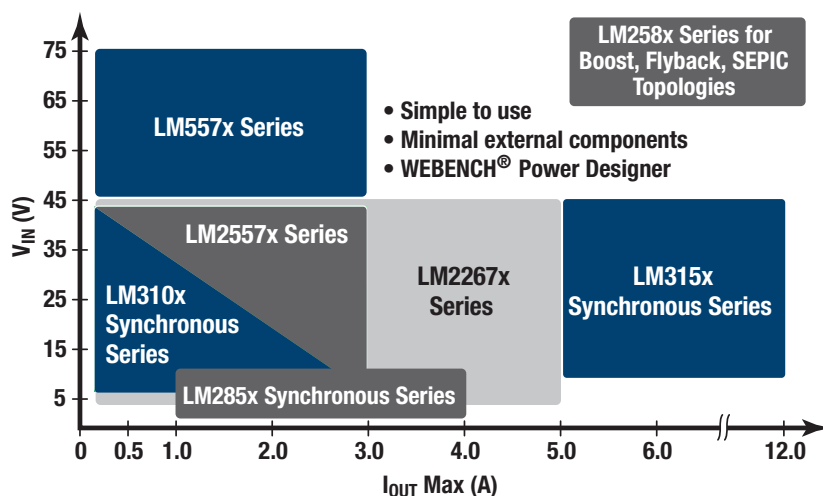

### LM2267x and LM22680 SIMPLE SWITCHER® Non-Synchronous Regulators

Device	Output Current (mA)	V <sub>IN</sub> (max) (V)	V <sub>IN</sub> (min) (V)	V <sub>OUT</sub> (min) (V)	Frequency Range (kHz)	f <sub>sync</sub>	PWM Mode	Package(s)	Price*
LM22671/74	500	42	4.5	1.285	200 to 1000 Adj	✓/–	Voltage	PSOP-8	1.38/1.32
LM22672/75	1000	42	4.5	1.285	200 to 1000 Adj	✓/–	Voltage	PSOP-8	1.78/1.68
LM22680	2000	42	4.5	1.285	200 to 1000 Adj	✓	Voltage	PSOP-8	1.85
LM22670/73/76	3000	42	4.5	1.285	200 to 1000 Adj	✓/–/–	Voltage	T0263-7 Thin, PSOP-8	1.98/1.98/1.92
LM22677/78/79	5000	42	4.5	1.285	200 to 1000 Adj	✓/–/–	Voltage	T0263-7 Thin	3.38/3.25/3.38

\*Suggested resale price in U.S. dollars in quantities of 1,000.

### LM2557x and LM557x SIMPLE SWITCHER® Non-Synchronous Regulators

Device	Output Current (mA)	V <sub>IN</sub> (max) (V)	V <sub>IN</sub> (min) (V)	V <sub>OUT</sub> (min) (V)	V <sub>OUT</sub> (max) (V)	Frequency Range (kHz)	f <sub>sync</sub>	On/Off Pin	PWM Mode	Package(s)	Price*
LM25574	500	42	6	1.23	40	50 to 1000	✓	✓	Current	TSSOP-16	1.48
LM5574	500	75	6	1.23	70	50	✓	✓	Current	TSSOP-16	1.75
LM25575	1500	42	6	1.23	40	50 to 1000	✓	✓	Current	eTSSOP-16	1.76
LM5575	1500	75	6	1.23	70	50	✓	✓	Current	eTSSOP-16	2.20
LM25576	3000	42	6	1.23	40	50 to 1000	✓	✓	Current	eTSSOP-20	2.40
LM5576	3000	75	6	1.23	70	50	✓	✓	Current	eTSSOP-20	3.05

\*Suggested resale price in U.S. dollars in quantities of 1,000.

### SIMPLE SWITCHER® Synchronous Regulators

Device	Output Current (mA)	V <sub>IN</sub> (max) (V)	V <sub>IN</sub> (min) (V)	V <sub>OUT</sub> (min) (V)	V <sub>OUT</sub> (max) (V)	Frequency Range (kHz)	PWM Mode	Package(s)	Price*
LM3103	750	42	4.5	0.6	38	1000	COT <sup>1</sup>	eTSSOP-16	1.80
LM3100	1500	36	4.5	0.8	7	1000	COT	eTSSOP-20	2.35
LM3102	2500	42	4.5	0.8	7	1000	COT	eTSSOP-20	1.90
LM2852	2000	5.5	2.85	0.8	3.3	500, 1500	Voltage	eTSSOP-14	2.59
LM2853	3000	5.5	3	0.8	3.3	550	Voltage	eTSSOP-14	2.00
LM2854	4000	5.5	2.95	0.8	5	500, 1000	Voltage	eTSSOP-16	2.40

<sup>1</sup>COT = Constant ON-time control.

\*Suggested resale price in U.S. dollars in quantities of 1,000.

# DC/DC Switching Regulators

## Step-Down Converters (Line and Portable Power)

### Selection Guide for Portable Power

Device	I <sub>OUT</sub> (mA)	V <sub>IN</sub> (V)	V <sub>OUT</sub> Adjustable/Fixed (V)	Peak Efficiency (%)	Switching Frequency (typ) (kHz)	Recommended Inductor Size (μH)	Quiescent Current (typ) (μA)	Shutdown Current (typ) (μA)	Power Good	Synch. to Ext. CLK (Opt.)	DCS-Control™ Topology	Package(s)	EVM	Features and Differentiators	Price*
<b>General Purpose, Step-Down (Buck) Regulators — Small, Efficient, Low I<sub>q</sub></b>															
TPS62240	300	2.0 to 6.0	Adj. (0.6 to V <sub>IN</sub> )/1.2/1.8	95	2250	2.2	15	0.1				SOT-23, QFN	✓		0.55
LM3670	350	2.5 to 5.5	0.7 to 3.3		1000	10	15	0.1				SOT-23	✓		0.57
LM3671	600	2.7 to 5.5	1.1 to 3.3		2000	2.2	16	0.01				SOT-23, QFN	✓		0.70
TPS62260	600	2.0 to 6.0	Adj. (0.6 to V <sub>IN</sub> )/1.2/1.8	95	2250	2.2	15	0.1				SOT-23, QFN	✓		0.65
TPS62250	700	2.0 to 6.0	Adj. (0.6 to V <sub>IN</sub> )	95	2250	2.2	15	0.1				QFN		USB applications	0.90
TPS62290	1000	2.3 to 6.0	Adj. (0.6 to V <sub>IN</sub> )/1.8/3.3	95	2250	2.2	15	0.1				QFN	✓		0.85
TPS62080	1200	2.3 to 6.0	Adj. (0.5 to 4.0)/1.8/3.3	94	2000	1	5	6.5	✓		✓	QFN, MSOP	✓	Snooze mode, active discharge	0.90
TPS62510	1500	1.8 to 3.8	Adj. (0.6 to V <sub>IN</sub> )	97	1500	2.2	18	0.1				QFN	✓	Output-voltage tracking	1.15
TPS62060	1600	2.3 to 6.0	Adj. (0.6 to V <sub>IN</sub> )/1.8/3.3	94	3000	1.0	18	0.1				QFN	✓		0.95
TPS62065	2000	2.3 to 6.0	Adj. (0.6 to V <sub>IN</sub> )	94	3000	1.0	18	0.1				QFN	✓		1.05
TPS62067	2000	2.9 to 6.0	Adj. (0.6 to V <sub>IN</sub> )	97	3000	1.0	18	0.1	✓			QFN	✓		1.10
TPS62090	3000	2.0 to 5.5	Adj. (0.8 to V <sub>IN</sub> )/1.8/2.5/3.3	96	2800/1400	0.47	20	0.6	✓		✓	QFN	✓	Adj. soft start, frequency select	1.15
<b>General Purpose, Step-Down (Buck) Regulators — Value Line, Relaxed Specification</b>															
TPS62560	600	2.5 to 5.5	Adj. (0.6 to V <sub>IN</sub> )/1.8	95	2250	2.2	15	0.1				SOT-23, QFN	✓	3% V <sub>OUT</sub> tolerance	0.50
TLV62080	1200	2.5 to 5.5	Adj. (0.5 to 4.0)	94	2000	1	30	0.6	✓		✓	QFN	✓		0.70
TLV62065	2000	2.9 to 6	Adj. (0.6 to V <sub>IN</sub> )	97	3000	1	18	0.1				QFN			0.75
TLV62090	3000	2.5 to 5.5	Adj. (0.8 to V <sub>IN</sub> )	96	1400	0.47	20	0.6	✓		✓	QFN		Adj. soft start	0.85
TLV62150	1000	4.0 to 17	Adj. (0.9 to 5.0)	96	2250	2.2	19	1.5	✓		✓	QFN		Adj. soft start (opt.)	0.75
TLV62130	3000	4.0 to 17	Adj. (0.9 to 5.0)	96	2250	2.2	19	1.5	✓		✓	QFN		Adj. soft start (opt.)	0.90
<b>Special-Function Step-Down (Buck) Regulators</b>															
TPS62730	100	1.9 to 3.9	1.9/2.1/2.3	95	3000	2.2	25	0.03			✓	QFN	✓	Bypass switch; for BLE and RF4CE	0.75
TPS62736	50	2.0 to 5.5	Adj. (1.3 to 5.0)	96	2000 (max)	10	0.35	0.02				QFN	✓	Ultra-low I <sub>q</sub> , low battery indicator	TBD
TPS62750	1300	2.9 to 6.0	Adj. (0.8 to 0.85 × V <sub>IN</sub> )	94	2250	2.2	745	0.3				QFN	✓	Powered by USB; progr. input-current limit	1.05
TPS62120	75	2.0 to 15	Adj. (1.2 to 5.5)	96	800	22	11	0.3	✓		✓	SOT-23, QFN	✓	Ext. UVLO hysteresis	0.75
TPS62125	250	3.0 - 17	Adj. (1.2 to 10)	93	1000	10	5	0.3	✓		✓	QFN		Program. EN threshold and hysteresis	0.85
<b>Extended Input-Voltage Range</b>															
TPS62170	500	3.0 to 17	Adj. (0.9 to 6)/1.8/3.3/5.0	92	2500	2.2	17	1.5	✓		✓	QFN	✓		0.75
TPS62175	500	4.75 to 28	Adj. (1 to 6)/3.3/5.0	90	1000	10	4.8	1.5	✓		✓	QFN		SLEEP mode	0.95
TPS62050	800	2.7 to 10.0	Adj. (0.7 to 6)/1.5/1.8/3.3	95	850	10	12	1.5	✓	✓		MSOP	✓	Low-battery indicator	1.10
TPS62150	1000	3.0 to 17	Adj. (0.9 to 6)/1.8/3.3/5.0	96	2500/1250	2.2	17	1.5	✓		✓	QFN	✓	Soft start (opt.), tracking, voltage and frequency select pin	1.00
TPS62160	1000	3.0 to 17	Adj. (0.9 to 6)/1.8/3.3/5.0	92	2500	2.2	17	1.5	✓		✓	QFN, VSSOP	✓		0.95
TPS62110	1500	3.1 to 17	Adj. (1.2 to 16)/3.3/5	95	1000	6.8	18	1.5	✓	✓		QFN	✓	Low-battery indicator	1.40
TPS62140	2000	3.0 to 17	Adj. (0.9 to 6)/1.8/3.3/5.0	96	2500/1250	2.2	17	1.5	✓		✓	QFN	✓	Soft start (opt.), tracking, voltage and frequency select pin	1.15
TPS62130	3000	3.0 to 17	Adj. (0.9 to 6)/1.8/3.3/5.0	96	2500/1250	2.2	17	1.5	✓		✓	QFN	✓	Soft start (opt.), tracking, voltage and frequency select pin	1.30
<b>Dual Output, 180° Out-of-Phase</b>															
TPS62400	400 + 600	2.5 to 6.0	Adj. (0.6 to V <sub>IN</sub> )/1.1 to 1.9/3.3	95	2250	3.3	30	0.1				QFN		EasyScale™ interface	0.95
TPS62410	800 + 800	2.6 to 6.0	Adj. (0.6 to V <sub>IN</sub> )	95	2250	3.3	30	0.1				QFN		EasyScale interface	1.15
TPS62420	600 + 1000	2.6 to 6.0	Adj. (0.6 to V <sub>IN</sub> )	95	2250	3.3	30	0.1				QFN	✓	EasyScale interface	1.15
<b>Smallest Solution Size, High Switching Frequency</b>															
TPS62619	350	2.3 to 5.5	1.2/1.5/1.8/2.15	90	6000	0.47	31	0.2				CSP		0.4-mm solution height	0.55
TPS62690	500	2.3 to 4.8	2.85	95	4000	1.0	19	0.2				CSP	✓	Spread spectrum	0.70
TPS62230	500	2.05 to 6.0	1.0 to 3.3	94	3000	1	22	0.1			✓	QFN	✓	Up to 90-dB PSRR	0.50
TPS62674	500	2.3 to 4.8	1.2/1.26/1.5/1.8	92	5500	0.47	17	0.2				CSP	✓	Spread spectrum	0.70
LM8801	600	2.3 to 5.5	1.0 to 2.9		6000							CSP	✓		0.80

All of the above devices have an on-chip soft start, undervoltage lockout and thermal protection built in.  
\*Suggested resale price in U.S. dollars in quantities of 1,000.

New devices are listed in **bold red**.  
Preview devices are listed in **bold teal**.

# DC/DC Switching Regulators

## Step-Down Converters (Line and Portable Power)

### Selection Guide for Portable Power (Continued)

Device	I <sub>OUT</sub> (mA)	V <sub>IN</sub> (V)	V <sub>OUT</sub> Adjustable/Fixed (V)	Peak Efficiency (%)	Switching Frequency (typ) (kHz)	Recommended Inductor Size (μH)	Quiescent Current (typ) (μA)	Shutdown Current (typ) (μA)	Power Good	Synch. to Ext. CLK (Opt.)	DCS-Control™ Topology	Package(s)	EVM	Features and Differentiators	Price*
<b>Smallest Solution Size, High Switching Frequency (Continued)</b>															
<b>TPS62620</b>	600	2.3 to 5.5	1.82/1.8/1.5/1.2	90	6000	0.47	31	0.2				CSP	✓		0.70
<b>LM3691</b>	1000	2.3 to 5.5	0.75 to 3.3		4000							CSP	✓		0.80
<b>TPS62660</b>	1000	2.3 to 5.5	1.2/1.8	91	6000	0.47	31	0.2				CSP	✓	Active cap discharge	0.90
<b>LM3678</b>	1500	2.5 to 5.5	0.8 to 3.3		3300							QFN	✓		1.15
<b>Processor Power, Dynamic Voltage Scaling</b>															
<b>TPS62270</b>	400	2.0 to 6.0	1.15/0.9, 3.3/2.1, 3.3/2.5	95	2250	2.2	15	0.1				QFN	✓	V <sub>SEL</sub> pin	0.70
<b>TPS62650</b>	800	2.3 to 5.5	Adj. (0.75 to 1.44)	86	6000	0.47	38	0.5				CSP		I <sup>2</sup> C interface	0.90
<b>TPS62360</b>	3000	2.5 to 5.5	Adj. (0.5 to 1.77)	91	2500	1	56	0.5			✓	CSP	✓	I <sup>2</sup> C interface, different. sense	1.45
<b>TPS62366</b>	4000	2.5 to 5.5	Adj. (0.5 to 1.77)	91	2500	1	56	0.5			✓	CSP	✓	I <sup>2</sup> C interface, different. sense	1.60
<b>TPS623850</b>	4700	2.5 to 5.5	Adj. (0.5 to 1.77)	91	4000	0.47	80	0.1	✓		✓	CSP		I <sup>2</sup> C interface; dual phase; phase shading; different. sense	TBD
<b>TPS623860</b>	6800	2.5 to 5.5	Adj. (0.5 to 1.77)	91	4000	0.47	80	0.1	✓		✓	CSP		I <sup>2</sup> C interface; dual phase; phase shading; different. sense	TBD
<b>TPS62387A</b>	8200	2.5 to 5.5	Adj. (0.5 to 1.77)	91	4000	0.47	80	0.1	✓		✓	CSP		I <sup>2</sup> C interface; dual phase; phase shading; different. sense	TBD

All of the above devices have an on-chip soft start, undervoltage lockout and thermal protection built in.  
 \*Suggested resale price in U.S. dollars in quantities of 1,000.

New devices are listed in **bold red**.  
 Preview devices are listed in **bold teal**.

### DC/DC Converter with DCS-Control™ Topology and Snooze Mode

#### TPS62080

The DCS-Control™ architecture (Direct Control with seamless transition into Power Save mode) used in TI's DC/DC converters is an advanced regulation topology that combines the advantages of hysteretic, voltage and current mode control.

- Immediate response to dynamic load changes: AC control loop takes information about output voltage changes and feeds it directly to a fast comparator stage.
- Voltage feedback loop achieves accurate DC load regulation.
- Internally compensated regulation network achieves fast and stable operation with small external components and low ESR capacitors.

The DCS-Control topology supports pulse-width modulation (PWM) for medium and heavy loads and seamlessly transitions to the Power Save mode to maintain high efficiency during light-load operation. This smoother transition overcomes the random jitter observed on older generations.

#### Key Features

- DCS-Control architecture for fast transient regulation
- Snooze mode for 6.5-μA ultra-low I<sub>Q</sub>
- 2.3- to 6-V input voltage range
- 100% duty cycle for lowest dropout
- Power save mode for light-load efficiency
- Output discharge function
- Short circuit protection
- Power Good output
- Thermal shutdown
- Available in 2x2-mm, 8-pin SON and VSSOP packages

#### Applications

- Battery-powered portable devices
- Point-of-load regulators
- System power rail voltage conversion

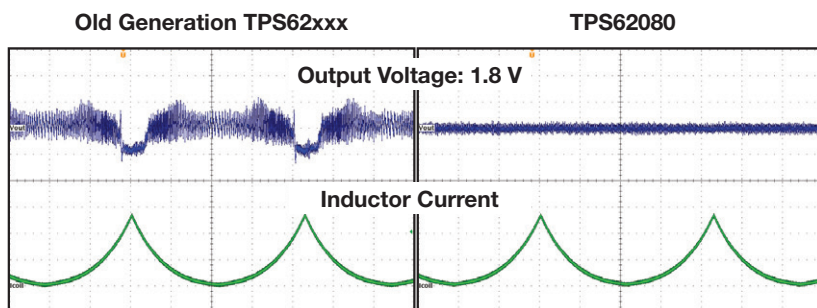

Seamless transition between PWM and Power Save mode with V<sub>IN</sub> = 3.6 V and a 0- to 500-mA triangle load sweep.

Get more information: [www.ti.com/product/TPS62080](http://www.ti.com/product/TPS62080) or [www.ti.com/dcs-control](http://www.ti.com/dcs-control)

# DC/DC Switching Regulators

## Step-Up (Boost)/Flyback/SEPIC and Inverting Converters

### DC/DC Step-Up Converters (Integrated Switch) Family of Products

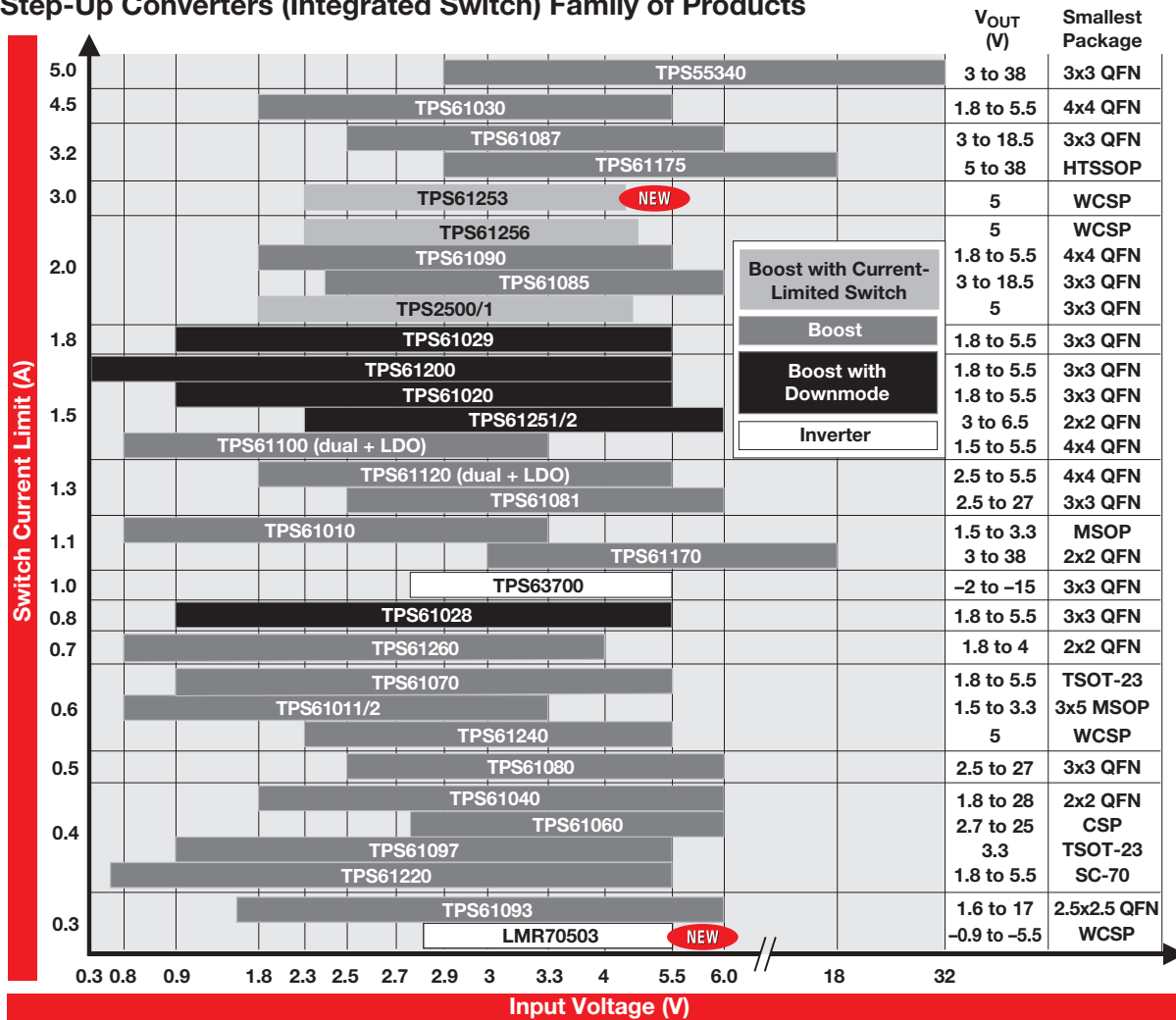

### 3.5-MHz, 1.5-A Boost Converter with Adjustable Input-Current Limit

#### TPS61252

Systems supplied from a current limited source, such as a battery or USB port, can face the problem of collapsing input voltage or under-voltage shutdown if the load draws a very high current for a short period of time. In the past, these systems used a capacitor bank with a current-limiting switch on the input to limit the average input current to a value that can be supplied by the source. This was necessary even if the load would not face a problem with a voltage drop of several hundred millivolts.

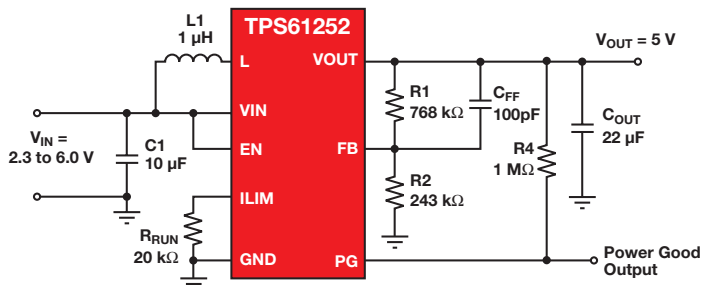

TPS61252 typical application.

#### Key Features

- Resistor-programmable input-current-limit protection:
  - ±20% current accuracy at 500 mA over full temperature range
  - Programmable from 100 mA up to 1500 mA
- Up to 92% efficiency
- V<sub>IN</sub> range from 2.3 to 6.0 V
- Adjustable output voltage up to 6.5 V
- 100% duty-cycle mode when V<sub>IN</sub> > V<sub>OUT</sub>
- Load disconnect and reverse-current protection
- Power Good
- Short circuit protection.
- Available in a 2x2-mm QFN-8 package

Get more information: [www.ti.com/product/TPS61252](http://www.ti.com/product/TPS61252)

# DC/DC Switching Regulators

## Step-Up (Boost)/Flyback/SEPIC and Inverting Converters

### Selection Guide for Step-Up (Boost) Converters

Device	I <sub>OUT</sub> (mA) <sup>1</sup>	Switch Current Limit (typ) (mA)	V <sub>IN</sub> (V)	V <sub>OUT</sub> Adj. (V)	V <sub>OUT</sub> Fixed (V)	Peak Efficiency (%)	Switching Frequency (typ) (kHz)	Recommended Inductor Size (µH)	Quiescent Current (typ) (µA)	Shutdown Current (typ) (µA)	Integrated LDO I <sub>OUT</sub> (mA)/V <sub>OUT</sub> (V)	Synchronous Rectification	Low Battery	Power Good	Undervoltage Lockout	Thermal and/or Short-Circuit Protection	Package(s)					EVM	Price*
																	WCGSP (Chip scale)	SOT-23	MSOP	QFN/LLP	TSSOP		
<b>Step-Up Regulators — Up to 6-A Switch Limit</b>																							
TPS61220/21/22	50	400	0.7 to 5.5	1.8 to 5.5	3.3/5	95	—	4.7	5.5	0.2	—	✓			✓	✓					✓	0.65	
TPS61041	50	250	1.8 to 6.0	V <sub>IN</sub> to 28	—	87	1000	10	28	0.1	—				✓	✓		5			✓	0.65	
TPS61040	90	400	1.8 to 6.0	V <sub>IN</sub> to 28	—	87	1000	10	28	0.1	—				✓	✓		5			✓	0.70	
TPS61260/61	100	700	0.8 to 4.0	1.8 to 4.0	3.3	95	2.3	4.7	29	0.1	—	✓			✓	✓			6		✓	0.70	
TL497A	—	500	4.5 to 12	(V <sub>IN</sub> + 2) to 30	—	85	—	—	11 mA	6000	—									14	14	0.90	
TPS61097-33	150	350	0.9 to 5.5	—	3.3	90	—	10	4	0.005	—	✓			✓	✓		5	6			0.75	
TPS61080	—	500	2.5 to 6.0	V <sub>IN</sub> to 27	—	87	1200	4.7	—	—	—				✓	✓			10		✓	1.35	
TPS61014/5/6	200	1000/1100/ 1130	0.8 to 3.3	—	2.8/3/3.3	95	500	10	36	1	—	✓	✓		✓	✓			10			1.10	
TPS61010	200	1130	0.8 to 3.3	1.5 to 3.3	—	95	500	10	36	1	—	✓	✓		✓	✓			10		✓	1.10	
TPS61028	200	800	0.9 to 5.5	1.8 to 5.5	—	96	720	6.8	25	0.1	—	✓	✓		✓	✓			10		✓	0.85	
TPS61070/1/2/3	250	700	0.9 to 5.5	1.8 to 5.5	—	90	1200 <sup>2</sup>	4.7	19	1	—	✓			✓	✓		6				0.80	
TPS61093	300	1100 <sup>3</sup>	1.6 to 6	V <sub>IN</sub> to 17	—	88	1200	10	0.9 mA	1	—				✓	✓			10		✓	1.30	
TPS61081	450	1200	2.5 to 6.0	V <sub>IN</sub> to 27	—	87	1200	4.7	—	—	—				✓	✓			6		✓	1.45	
TPS61240/41	450	600/700	2.3 to 5.5	—	5	90	3500	1	30	1.5	—	✓			✓	✓		6	6		✓	0.80	
TPS61170	500	1200	3.0 to 18	V <sub>IN</sub> to 38	—	93	1200	10	—	1	—				✓	✓						1.40	
TPS61020	500	1500	0.9 to 5.5	1.8 to 5.5	—	96	720	6.8	25	0.1	—	✓	✓		✓	✓			10		✓	0.95	
TPS61024/5/7	500	1500	0.9 to 5.5	1.8 to 5.5	3/3.3/5	96	720	6.8	25	0.1	—	✓	✓		✓	✓			10		✓	0.95	
TPS61251	500	1500	2.3 to 6	3 to 6	—	92	3500	1	30	0.85	—	✓		✓	✓	✓			8		✓	1.60	
TPS61252	500	1500	2.3 to 6	3 to 6	—	92	3500	1	30	0.85	—	✓		✓	✓	✓			8		✓	1.25	
LM5002	500	—	3.1 to 75	1.26 and up	—	95	1500	330	3100	95	—				✓	✓			8	8	✓	1.70	
TPS61026/9	600	1800	0.9 to 5.5	1.8 to 5.5	—	96	720	6.8	25	0.1	—	✓	✓		✓	✓			10		✓	1.10	
TPS61090	700	2200	1.8 to 5.5	1.8 to 5.5	—	96	600	6.8	20	0.1	—	✓	✓		✓	✓			16		✓	1.70	
TPS61091/2	700	2000	1.8 to 5.5	—	3.3/5	96	600	6.8	20	0.1	—	✓	✓		✓	✓			16		✓	1.70	
MC34063A	750	1500	3 to 40	3 to 39.5	—	—	100	—	—	1	—				✓	✓			8	8	✓	0.21	
TPS61200/1/2	800	1500	0.3 to 5.5	0 to V <sub>IN</sub>	3.3/5	90	1250	2.2	50	1	—	✓			✓	✓			10		✓	0.95	
<b>TPS61254/6</b>	1000	2150	2.5 to 4.35/4.85	—	4.5/5	93	3500	1	22	0.85	—	✓			✓	✓		9			✓	1.60	
TPS61030/1/2	1000	4500	1.8 to 5.5	1.8 to 5.5	3.3/5	96	600	6.8	20	0.1	—	✓	✓		✓	✓			16	16	✓	2.10	
LM5001	1000	—	3.1 to 75	1.26 and up	—	96	1500	100	3100	95	—				✓	✓			8	8	✓	1.85	
LM27313	1000	—	2.7 to 14	V <sub>IN</sub> to 28	—	90	1600	10	2100	—	—				✓	✓		5			✓	0.61	
LM2733	1000	—	2.7 to 14	V <sub>IN</sub> to 40	—	90	1600	10	2100	—	—				✓	✓		5			✓	1.04	
LM4510	1200	—	2.7 to 5.5	V <sub>IN</sub> to 18	—	85	1000	4.7	1700	—	—				✓	✓			10		✓	1.80	
TPS61175	1300	3800	2.9 to 18	V <sub>IN</sub> to 38	—	95	2200	10	—	<1.5	—				✓	✓				14	✓	1.80	
LM2698	1350	—	2.7 to 12	V <sub>IN</sub> to 17	—	94	1250	10	1300	—	—				✓	✓			8		✓	1.83	
<b>TPS61253/58/59</b>	1500	3150	2.5 to 4.5	—	4.5/5/5.1	94	3500	1	22	0.85	—	✓			✓	✓		9			✓	1.45	
LM2731	1500	—	2.7 to 14	V <sub>IN</sub> to 22	—	90	1600	10	2000	—	—				✓	✓		5			✓	1.08	
LM2622	1600	—	2 to 12	V <sub>IN</sub> to 18	—	90	1300	10	1300	—	—				✓	✓			8		✓	0.91	
LM5000	2000	—	3.1 to 40	1.26 and up	—	90	1300	33	2000	18	—				✓	✓			16	16	✓	2.00	
LM3310	2000	—	2.5 to 7	V <sub>IN</sub> to 20	—	93	1280	10	3100	—	—				✓	✓			24		✓	1.38	
LM3311	2000	—	2.5 to 7	V <sub>IN</sub> to 20	—	93	1280	10	3100	—	—				✓	✓			24		✓	1.38	
TPS61230	2000	5500	2.3 to 5.5	2.4 to 5.25	3.3/5	96	2000	1	35	1	—	✓			✓	✓			10		✓	TBD	
LM2623	2200/ 1200	—	0.8 to 14	1.24 to 14	—	90	2000	4.7	80	—	—				✓	✓			8	14	✓	1.09	
LM2735	2250	—	2.7 to 5.5	V <sub>IN</sub> to 24	—	90	1600	15	3400	—	—				✓	✓		5	8	6	✓	1.25	
LM3224	2600	—	2.7 to 7	V <sub>IN</sub> to 20	—	90	1250	10	1300	—	—				✓	✓			8		✓	1.10	
LM2700	3600	—	2.2 to 12	1.26 to 17.5	—	92	1250	4.7	1300	—	—				✓	✓			14	14	✓	1.71	
<b>TPS55340</b>	5000	6600	2.9 to 32	3 to 38	—	95	1200	10	500	2.7	—			✓	✓	✓			16	14	✓	1.80	

<sup>1</sup>For boost converters, max. I<sub>OUT</sub> can be estimated with 0.65 × switch limit × (V<sub>IN</sub>/V<sub>OUT</sub>).

<sup>2</sup>PWM/PFM (TPS61070); PWM only (TPS61071).

<sup>3</sup>Output current is limited to 300 mA.

\*Suggested resale price in U.S. dollars in quantities of 1,000.

New devices are listed in **bold red**.  
Preview devices are listed in **bold teal**.



# DC/DC Switching Regulators

## Step-Up (Boost)/Flyback/SEPIC and Inverting Converters

### Selection Guide for Step-Up (Boost) Converters (Continued)

Device	I <sub>OUT</sub> (mA) <sup>1</sup>	Switch Current Limit (typ) (mA)	V <sub>IN</sub> (V)	V <sub>OUT</sub> Adj. (V)	V <sub>OUT</sub> Fixed (V)	Peak Efficiency (%)	Switching Frequency (typ) (kHz)	Recommended Inductor Size (µH)	Quiescent Current (typ) (µA)	Shutdown Current (typ) (µA)	Integrated LDO I <sub>OUT</sub> (mA)/V <sub>OUT</sub> (V)	Synchronous Rectification	Low Battery	Power Good	Undervoltage Lockout	Thermal and/or Short-Circuit Protection	Package(s)					EVM	Price*
																	WGSP (Chip scale)	SOT-23	MSOP	QFN/LLP	TSSOP		
<b>Step-Up (Boost) Regulators with Integrated LDO (Dual Output)</b>																							
TL499A	100	—	1.1 to 10	2.9 to 30	—	85	—	—	—	15	100/Adj.									8		1.20	
TPS61100	200	1500	0.8 to 3.3	1.5 to 5.5	—	95	500	10	65	0.5	120/Adj.	✓	✓	✓	✓	✓				24	20	✓	1.50
TPS61103/6/7	200	1500	0.8 to 3.3	—	3.3/3.3/3.3	95	500	10	65	0.5	120/Adj., 1.5, 1.8	✓	✓	✓	✓	✓				24	20		1.50
TPS61120	500	1300	1.8 to 5.5	2.5 to 5.5	—	95	500	10	40	0.2	200/Adj.	✓	✓	✓	✓	✓				16	16	✓	1.65
TPS61121/2	500	1300	1.8 to 5.5	—	3.3/3.6	95	500	10	40	0.2	200/1.5, 3.3	✓	✓	✓	✓	✓				16	16		1.65
<b>Inverting Regulators</b>																							
LMR70503	—	300	2.8 to 5.5	-0.9 to -5.5	—	79	500	—	0.245 mA	0.01	—				✓	✓	6					✓	1.15
TL497A	—	500	4.5 to 12	-1.2 to -25	—	85	—	—	11 mA	6000	—									14	14		0.90
TPS63700	360	1000	2.7 to 5.5	-2 to -15	—	84	1400	4.7	—	0.014	—									10		✓	1.30
MC34063A	750	1500	3 to 38	-1.25 to -36.3	—	—	100	—	0.330 mA	—	—				✓	✓				8	8	✓	0.21

<sup>1</sup>For boost converters, max. I<sub>OUT</sub> can be estimated with 0.65 × switch limit × (V<sub>IN</sub>/V<sub>OUT</sub>).

<sup>3</sup>Output current is limited to 300 mA.

\*Suggested resale price in U.S. dollars in quantities of 1,000.

New devices are listed in bold red. Preview devices are listed in bold teal.

<sup>2</sup>PWM/PFM (TPS61070); PWM only (TPS61071).

### SIMPLE SWITCHER<sup>®</sup> Boost/Flyback/SEPIC

Device	I <sub>OUT</sub> (A)	V <sub>IN</sub> (max) (V)	V <sub>IN</sub> (min) (V)	V <sub>OUT</sub> (min) (V)	Frequency Range (kHz)	Package(s)	Price*
LM2585	3	40	4	1.23	100	TO-220, TO-263	3.17
LM2586	3	40	4	1.23	100 to 200	TO-220, TO-263	3.27
LM2587	5	40	4	1.23	100	TO-220, TO-263	4.17
LM2588	5	40	4	1.23	100 to 200	TO-220, TO-263	4.50

\*Suggested resale price in U.S. dollars in quantities of 1,000.

### SIMPLE SWITCHER<sup>®</sup> Step-Up (Boost) Nano Regulators

The new SIMPLE SWITCHER nano regulators feature tiny packaging, 1-MHz or greater switching frequency for extremely small surface mount inductors and chip capacitors, and a minimal BOM to reduce board space. All nano regulators are offered in either LLP, SOT-23, or micro SMD packaging for added design flexibility.

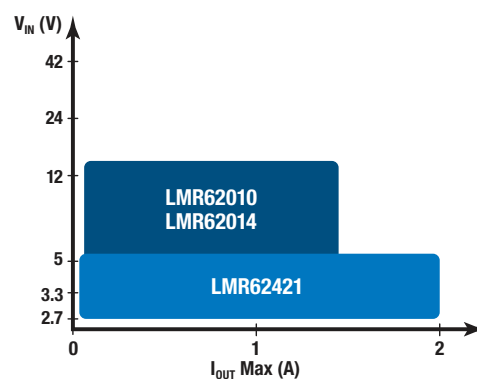

### SIMPLE SWITCHER<sup>®</sup> Step-Up (Boost) Nano Regulators

Device	Output Current (max) (A)	Input Voltage (V)	Adjustable Output Voltage (V)	Frequency (kHz)	Features	Package(s)	Price*
LMR62421	2.1	2.7 to 5.5	3 to 24	1600	EN, SS	SOT-23, LLP-6	0.74
LMR62014	1.4	2.7 to 14	3 to 20	1600	EN	SOT-23	0.54
LMR64010	1	2.7 to 14	3 to 40	1600	EN	SOT-23	0.59

\*Suggested resale price in U.S. dollars in quantities of 1,000.

# DC/DC Switching Regulators

## Buck-Boost Converters

### Industry's Smallest High-Efficiency, Single-Inductor Buck-Boost Converter

#### TPS63036

The TPS63036 is the smallest single-inductor buck-boost converter in the industry. It has a 1.6 x 1.0-mm footprint, achieving a total solution size of less than 21 mm<sup>2</sup> (see block diagram). The device features a 1-A switch current limit and can reach a 94% conversion efficiency over a wide load range due to its reduced operating quiescent current of less than 30 µA (typical). The TPS63036 has a wide input-voltage range, supporting new Li-Ion batteries as well as two- and three-cell alkaline, NiCd or NiMH batteries.

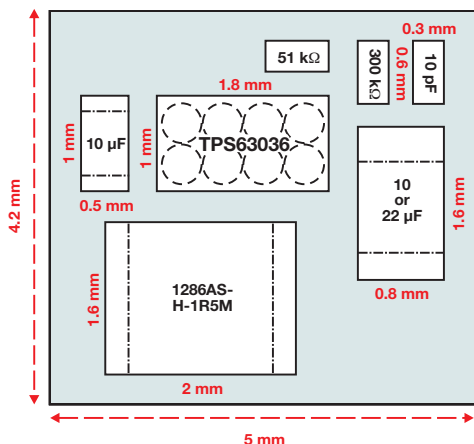

Buck-boost converter total solution size of less than 21 mm<sup>2</sup>.

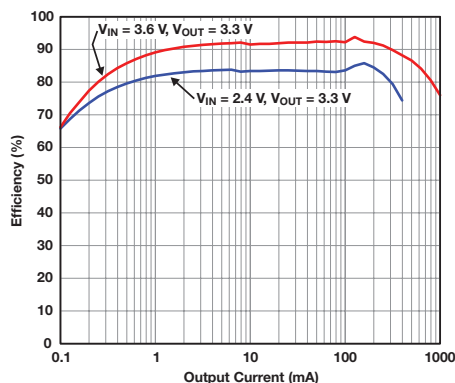

Efficiency versus output current.

#### Key Features

- Automatic transition between step-down and boost mode
- With  $V_{OUT} = 3.3$  V, the TPS63036 delivers up to 450 mA from a 1.8-V source, up to 550 mA from a 2.5-V source, and up to 1000 mA from a 5-V source
- Power-save mode at light loads with  $I_q < 30$  µA (typ)
- 2.4-MHz switching frequency, externally synchronizable ( $\pm 20\%$ )
- Load disconnect during shutdown

#### Applications

- All 2- and 3-cell alkaline, NiCd or NiMH or single-cell Li-Ion battery powered products
- Cellular phones
- Tablet PCs
- Portable players
- Personal medical products
- White LEDs

Get more information: [www.ti.com/product/TPS63036](http://www.ti.com/product/TPS63036)

### Selection Guide

Device	$I_{OUT}$ (mA)	Switch-Current Limit (typ) (mA)	$V_{IN}$ (V)	$V_{OUT}$ Adj. (V)	$V_{OUT}$ Fixed (V)	Peak Efficiency (%)	Switching Frequency (typ) (kHz)	Recommended Inductor Size (µH)	Quiescent Current (typ) (µA)	Shutdown Current (typ) (µA)	Integrated LDO $I_{OUT}$ (mA)/ $V_{OUT}$ (V)	Low Battery	Power Good	Undervoltage Lockout	Thermal and/or Short-Circuit Protection	Package(s)			EVM	Price*
																WCSP (Chip scale)	QFN	TSSOP		
<b>TPS61130</b>	300	1300	1.8 to 5.5	2.5 to 5.5	—	90	500	10	40	0.2	200/Adj.	✓	✓	✓	✓	16	16	✓	1.55	
<b>TPS61131/2</b>	300	1300	1.8 to 5.5	—	3.3/3.3	90	500	10	40	0.2	200/1.5, 3.3	✓	✓	✓	✓	16	16	✓	1.55	
<b>TPS63030/31/36</b>	800	1000	1.8 to 5.5	1.2 to 5.5	3.3	96	2400	1.5	25	0.1	—	✓	✓	✓	✓	8	10	✓	1.20	
<b>TPS63050</b> <sup>1</sup>	800	1000	2.5 to 5.5	2.5 to 5.5	3.3	98	2500	1.5	25	0.1	—	✓	✓	✓	✓	12	—	✓	TBD	
<b>LM3668</b>	1000	1850	2.8 to 5.5	2.8 to 5.0	—	96	2200	2.2	45	0.01	—	—	—	✓	✓	12	—	✓	2.25	
<b>TPS63000/1/2</b>	1200	1800	1.8 to 5.5	1.2 to 5.5	3.3/5.0	90	1400	2.2	30	0.1	—	—	—	✓	✓	10	—	✓	1.50	
<b>TPS63010/11/12</b>	1200	2200	2 to 5.5	1.2 to 5.5	3.3/3.4/2.8/2.9	96	2400	1.5	30	0.1	—	—	—	✓	✓	20	—	✓	1.50	
<b>TPS63060/1</b>	1200	1800	2.5 to 8	2.5 to 12	5	93	2400	2.2	30	—	—	✓	✓	✓	✓	10	—	✓	1.40	
<b>TPS63020</b>	3000	4000	1.8 to 5.5	1.2 to 5.5	3.3	96	2400	1.5	30	0.1	—	✓	✓	✓	✓	14	—	✓	2.50	

<sup>1</sup>Adjustable average input-current limit and soft start.

\*Suggested resale price in U.S. dollars in quantities of 1,000.

New devices are listed in bold red. Preview devices are listed in bold teal.

# DC/DC Switching Regulators

## Controllers (External Switch)

### 3- to 20-V PMBus Synchronous Buck Controller

#### TPS40400

The TPS40400 is a cost-optimized flexible synchronous buck controller that operates from a nominal 3- to 20-V supply. This controller is an analog PWM controller that allows programming and monitoring via the PMBus interface. Flexible features found on this device include programmable soft-start time, programmable short circuit limit and programmable undervoltage lockout (UVLO).

#### Key Features

- Input operating voltage: 3 to 20 V
- PMBus enabled analog controller
- Reference 600 mV  $\pm$  1%
- Remote voltage sense amplifier
- Internal 6-V regulator and 6-V gate drive
- Programmable overcurrent protection
- Inductor resistance or series resistance used for current sensing
- Programmable switching frequency: 200 kHz to 2 MHz

#### Applications

- Powergood indicator
  - Thermal shutdown
  - Programmable soft-start
  - Internal bootstrap diode
  - Pre-bias output safe
  - 24-pin QFN package
- #### Applications
- Smart power systems
  - Power supply modules
  - Communications equipment
  - Computing equipment

Get more information: [www.ti.com/product/TPS40400](http://www.ti.com/product/TPS40400)

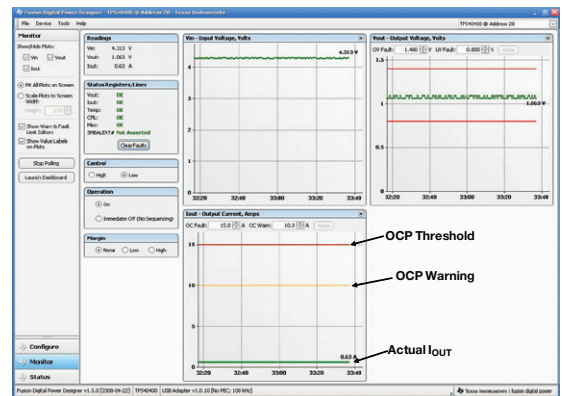
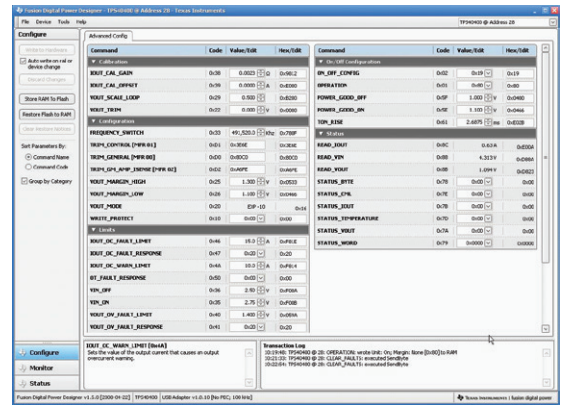

TPS40400 evaluation module GUI.

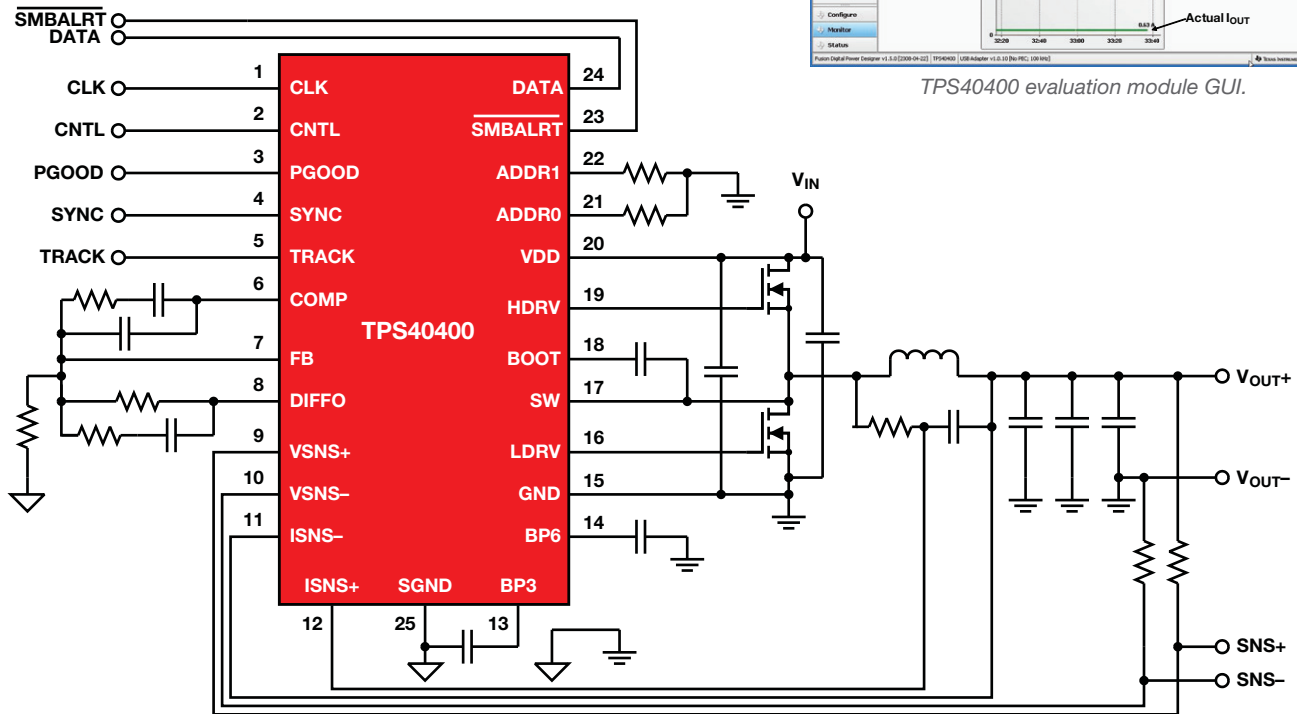

TPS40400 typical application.

# DC/DC Switching Regulators

## Controllers (External Switch)

### High-Voltage Synchronous Buck Controllers with Analog Current Monitor

#### LM(2)5117

The LM(2)5117 are synchronous buck controllers intended for step-down regulator applications from a high-voltage or widely varying input supply. The control method is based upon current mode control utilizing an emulated current ramp. Current mode control provides inherent line feed-forward, cycle-by-cycle current limiting and ease of loop compensation. The use of an emulated control ramp reduces noise sensitivity of the pulse-width modulation circuit, allowing reliable control of very small duty cycles necessary in high-input-voltage applications.

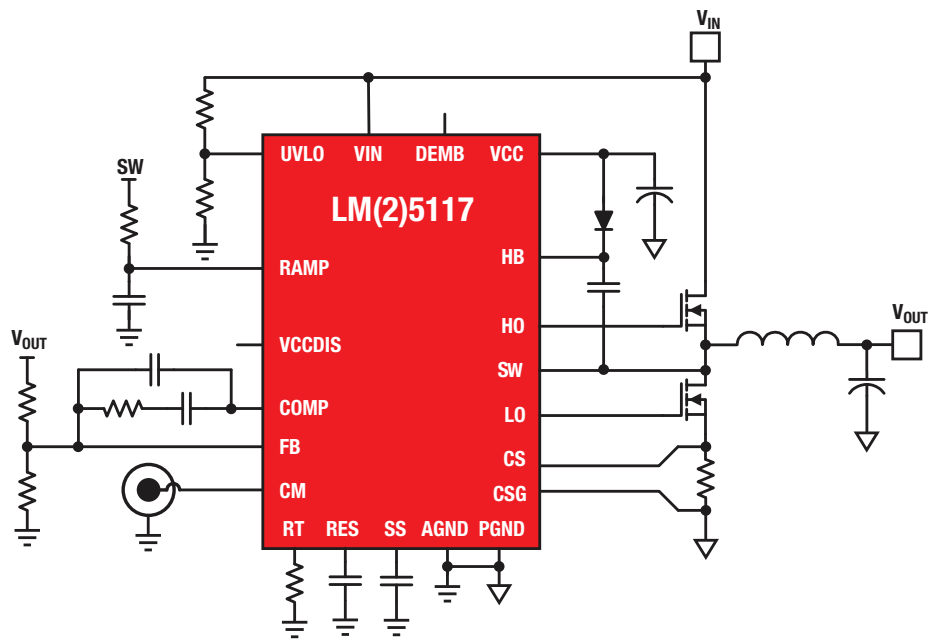

#### Key Features

- AECQ-100 Grade 1 qualified
- Emulated current mode (ECM)
- Wide operating range:
  - 5.5 to 65 V (LM5117)
  - 4.5 to 42 V (LM25117)
- Analog current monitor
- Robust 3.3-A peak gate drives
- Optional diode emulation mode
- Programmable output from 0.8 V

#### Applications

- Base stations
- Servers
- Routers
- Systems with widely changing input voltage
- Systems that require large step-down conversions
- Automotive infotainment systems

Get more information: [www.ti.com/product/LM5117](http://www.ti.com/product/LM5117) or [LM25117](http://www.ti.com/product/LM25117)

### SIMPLE SWITCHER® Synchronous Controllers

Device	V <sub>IN</sub> (max) (V)	V <sub>IN</sub> (min) (V)	V <sub>OUT</sub> (min) (V)	V <sub>OUT</sub> (max) (V)	Feedback Tolerance (%)	Frequency Range (kHz)	Package(s)	Price*
LM3150	42	6	0.6	Adj	1.50	Adj to 1 MHz	eTSSOP-14	2.30
LM3151	42	6	3.3	3.3	1.50	250 kHz	eTSSOP-14	2.30
LM3152	33	6	3.3	3.3	1.50	500 kHz	eTSSOP-14	2.30
LM3153	18	6	3.3	3.3	1.50	750 kHz	eTSSOP-14	2.30

\*Suggested resale price in U.S. dollars in quantities of 1,000.

# DC/DC Switching Regulators

## Controllers (External Switch)

### Selection Guide

All parts have soft start, short-circuit protection, and undervoltage lockout functions.

Device	Mode of Control <sup>1</sup>	V <sub>IN</sub> (min/max) (V)	V <sub>O</sub> (min/max) (V)	Driver Current (A)	Output Current (A) <sup>2</sup>	Frequency (kHz)	V <sub>REF</sub> Tol (%)	Internal Bootstrap	Package(s)	Pwr Good	Source and Sink <sup>3</sup>	Pre-biased Operation	Ext Synchron Pin	Predictive Gate Drive™	DDR <sup>4</sup>	Remote Sense	Price*
<b>General-Purpose DC/DC Step-Down Controllers</b>																	
TPS40000/2	V	2.25 to 5.5	0.7 to 4	1	15	300/600	1	Yes	10 MSOP			Yes		Yes			0.99
TPS40007/9	V	2.25 to 5.5	0.7 to 4	1	15	300/600	1	Yes	10 MSOP		Yes <sup>10</sup>	Yes		Yes			1.20
TPS40040	V	2.25 to 5.5	0.6 to 4.95	1	15	300	1	Yes	8 SON		Yes <sup>10</sup>	Yes					0.90
TPS40041	V	2.25 to 5.5	0.6 to 4.88	1	15	600	1	Yes	8 SON		Yes <sup>10</sup>	Yes					0.90
TPS40042	V	3 to 5.5	0.7 to 4.95	1.2	15	600	Ext	Yes	10 SON		Yes <sup>10</sup>	Yes			Yes		0.90
TPS40020/21	V	2.25 to 5.5	0.7 to 4	2	25	Adj. to 1000	1	Yes <sup>8</sup>	16 HTSSOP	Yes	21 <sup>10</sup>	20	Yes	Yes			1.45
LM3743	V	3 to 5.5	0.8 to 4.6	3.1	10	300 to 1000	1.75		10 MSOP				Yes				1.10
LM2745	V	1 to 17	0.6	1.9	20	50 to 1000	1.5		14 TSSOP	Yes		Yes	Yes				1.15
LM3475	Hysteretic	2.7 to 10	0.8 to V <sub>IN</sub>	0.5	5	0 to 2000	1.5		5 SOT23								0.52
TPS40190	V	4.5 to 15	0.59 to 12.75	1.2	20	300	1	Yes	10 SON		Yes <sup>10</sup>	Yes					1.00
LM2742	V	1 to 16	0.6	1.6	20	50 to 2000	1.5		14 TSSOP	Yes							1.25
LM2743	V	1 to 16	0.6	1.6	20	50 to 1000	2		14 TSSOP	Yes							1.15
LM2744	V	1 to 16	0.6	1.6	20	50 to 1000	1.5		14 TSSOP	Yes							1.15
LM2748	V	1 to 16	0.6	1.9	20	50 to 1000	1.5		14 TSSOP	Yes		Yes	Yes				1.15
LM2747	V	1 to 17	0.6	1.9	20	50 to 1000	1		14 TSSOP	Yes		Yes	Yes				1.45
TPS40100 <sup>5</sup>	C	4.5 to 18	0.7 to 5.5	1.3	20	600	1		24 QFN	Yes	Yes <sup>10</sup>	Yes	Yes			Yes	1.95
TPS40101 <sup>5</sup>	V	4.5 to 18	0.7 to 5.5	1.3	20	1000	1		24 QFN	Yes	Yes <sup>10</sup>	Yes	Yes			Yes	1.95
LM3753/54	V	4.5 to 18	0.6 to 3.6	1.9	50	200 to 1000	1		32 LLP	Yes		Yes	Yes			Yes	2.95
TPS40192/3	V	4.5 to 18	0.59 to 14.4	1.2	15/20	600/300	0.5	Yes	10 SON	Yes	Yes <sup>10</sup>	Yes					1.05
TPS40195 <sup>6</sup>	V	4.5 to 20	0.59 to 17	1.2	20	Adj. to 600	0.5	Yes	16 TSSOP, 16 QFN	Yes	Yes <sup>10</sup>	Yes	Yes <sup>7</sup>				1.50
TPS40400	VFF, PMBus	3 to 20	0.6 to 12	2	25	Adj. to 2000	1	Yes	24 QFN	Yes	Yes	Yes	Yes			Yes	2.15
TPS40303/4/5	V	3 to 20	0.6 to 18	2	25	300/600/1200	1	Yes	10 SON	Yes	Yes <sup>10</sup>	Yes					1.50
LM27402	V	3 to 20	0.6 to 19	2.6	30	200 to 1200	1		LLP-16, 16 TSSOP	Yes		Yes	Yes				1.68
TPS53124 (dual output)	D-CAP™ Mode	4.5 to 26	0.76 to 5.5	0.7	12	380	1	Yes	24 QFN, 28 TSSOP		Yes	Yes					1.95
TPS53125/26/27 (dual output)	D-CAP2™ Mode	4.5 to 26	0.76 to 5.5	0.7	12	350/700	1	Yes	24 QFN, 24 TSSOP		Yes	Yes					2.35
TPS53114	D-CAP2 Mode	4.5 to 27	0.76 to 5.5	0.7	12	350/700	1	Yes	16 TSSOP, 16 HTSSOP		Yes	Yes					1.00
TPS40075	VFF	4.5 to 28	0.7 to 23	1	20	Adj. to 1000	1	Yes	20 QFN	Yes	Yes <sup>10</sup>	Yes	Yes	Yes		Yes	1.80
TPS40077	VFF	4.5 to 28	0.7 to 23	1	20	Adj. to 1000	1	Yes	16 PowerPAD™	Yes	Yes <sup>10</sup>	Yes		Yes			1.60
LM3485	Hysteretic	4.5 to 35	1.242 to V <sub>IN</sub>	0.4	4	0 to 1400	2		8 MSOP								0.55
LM3489	Hysteretic	4.5 to 35	1.239 to V <sub>IN</sub>	0.4	4	0 to 1400	2		8 MSOP								0.62
LM3477	C	2.97 to 35	1.265 to 30.8	1.0	6	500	1.5		8 MSOP								0.92
TPS40054/55/57	VFF	8 to 40	0.7 to 35	1	20	Adj. to 1000	1	Yes	16 PowerPAD		55, 57 <sup>10</sup>	57	Yes				1.65
TPS40056	V	10 to 40	0.7 to 35	1	20	Adj. to 1000	Ext	Yes	16 PowerPAD		Yes		Yes		Yes		1.65
TPS40200 <sup>7</sup>	VFF	4.5 to 52	0.7 to 46	0.2	3	Adj. to 500	1	Note 9	8 SOIC				Yes				0.75
TPS40170	VFF	4.5 to 60	0.6 to 58	1.2	15	Adj. to 600	1	Yes	20 QFN	Yes	Yes <sup>10</sup>	Yes	Yes				2.25
LM(2)5117	ECM	4.5 to 65	0.8 to 60	2.2	20	50 to 750	1.5		20 TSSOP, 24 LLP				Yes				1.75/2.04
LM(2)5085/A	COT	4.5 to 42/75	1.25/0.9 to V <sub>IN</sub>	1.5	10	1000	2		8 MSOP, 8 LLP								0.79/0.85/1.00
LM(2)5088	ECM	4.5 to 42/75	1.2 to 40/70	1.5	10	50 to 1000	1.5		e16 TSSOP				Yes				1.40/1.84
LM(2)5115/A	V	4.5 to 42/75	0.75 to 13.5	2.5	20	100 to 1000	1.7		16 TSSOP				Yes				1.40/1.85
LM(2)5116	ECM	6 to 100	1.2 to 80	3.5	20	50 to 1000	1.5		20 eTSSOP				Yes				1.85/2.42

<sup>1</sup>V = Voltage-mode control, C = Current-feedback control, VFF = Voltage mode with voltage feed-forward compensation, ECM = Emulated current mode and COT = Constant ON-time control.

<sup>2</sup>Current levels of this magnitude can be supported with commonly available commercial FETs.

<sup>3</sup>The controller of choice for most applications will be the source/sink version, which has two-quadrant operation and will source or sink output current.

<sup>4</sup>DDR = Supports DDR memory.

<sup>5</sup>Provides advanced start-up sequencing and output voltage margining.

<sup>6</sup>Bidirectional 180° out-of-phase synchronization.

<sup>7</sup>Non-synchronous, drives P-FETs.

<sup>8</sup>Integrated voltage-doubler charge pump for higher drive voltage.

<sup>9</sup>Drives high-side P-FET.

<sup>10</sup>During soft start: source only.

\*Suggested resale price in U.S. dollars in quantities of 1,000.

# DC/DC Switching Regulators

## Controllers (External Switch)

### Selection Guide (Continued)

All parts have soft start, short-circuit protection, and undervoltage lockout functions.

Device	Mode Control <sup>1</sup>	Switched Outputs	Phases	V <sub>IN</sub> (min/max) (V)	V <sub>O</sub> (min/max) (V)	Driver Current (A)	Output Current (A) <sup>2</sup>	Frequency (kHz)	V <sub>REF</sub> Tol (%)	Package(s)	Pwr Good	Overshoot Protection	Source and Sink <sup>3</sup>	Pre-biased Operation	Ext Synch Pin	Remote Sense	Price*
<b>Multiphase Synchronous DC/DC Buck Controllers</b>																	
LM2642	C	1 or 2	1 or 2	4.5/30	1.3/96% x V <sub>IN</sub>	1.1	25/phase	300	1.8	28L TSSOP	Yes	Yes	—	—	No	—	1.48
LM2647	VFF	1 or 2	1 or 2	5.5/28	0.6/7.8	2	25/phase	Adj. 200 to 500	1.5	28L TSSOP	Yes	Yes	—	—	No	—	1.80
LM2657	VFF	1 or 2	1 or 2	4.5/28	0.6/7.4	2	25/phase	Adj. 200 to 500	1.5	28L TSSOP	Yes	Yes	—	—	No	—	1.80
LM3000	ECM	1 or 2	1 or 2	3.3/18.5	0.6/80% x V <sub>IN</sub>	—	25/phase	Adj. 200 to 1500	1.5	32L LLP	Yes	Yes	—	Yes	No	—	2.75
LM3753	VFF	1 or 2	1 or 2	4.5/18	0.6/3.6	4	25/phase	Adj. 200 to 1000	1	32L LLP	Yes	Yes	—	Yes	Yes	—	2.75
LM3754	VFF	1 or 2	1 or 2	4.5/18	0.6/3.6	4	25/phase	Adj. 200 to 1000	1	32L LLP	Yes	Yes	—	Yes	Yes	—	2.75
LM(2)5119	ECM	1	2	4.5/5.5 to 42/65	0.8 to 38/59	2.2	50	50 to 750	1.5	32 LLP	—	—	—	—	Yes	—	2.60/3.25
LM5642	C	1 or 2	1 or 2	4.5/36	1.3/90% x V <sub>IN</sub>	1.1	25/phase	200	1.7	28L TSSOP	No	Yes	—	—	Yes	—	1.75
LM5642x	C	1 or 2	1 or 2	4.5/36	1.3/90% x V <sub>IN</sub>	1.1	25/phase	375	1.7	28L TSSOP	No	Yes	—	—	Yes	—	1.75
TPS40132	C	1	2	1/40	0.6/5.8	1	50	Adj. to 1000	0.8	32 QFN	Yes	Yes	Yes	Yes	Yes	Yes	2.95
TPS40140 <sup>4</sup>	C	1 or 2	1 or 2	2/40	0.7/5.8	1.2	25/phase	Adj. to 1000	0.5	36 QFN	Yes	Yes	Yes	Yes	Yes	Yes	3.05
TPS40180 <sup>5</sup>	C	1	1	2/40	0.7/5.8	1.2	25	Adj. to 1000	0.75	24 QFN	Yes	Yes	Yes	Yes	Yes	Yes	2.05
TPS40322	VFF	1 or 2	1 or 2	3/20	0.6/5.6	2	25/phase	Adj. to 1000	1	32 QFN	Yes	Yes	Yes	Yes	Yes	Yes	2.40
TPS40422	VFF/PMBus	1 or 2	1 or 2	4.5/20	0.6/5.6	2	25/phase	Adj. to 1000	1	40 QFN	Yes	Yes	Yes	Yes	Yes	Yes	3.10
TPS51631	D-CAP+™	1	3	4.5/28	0.5/2.3	—	30	Adj. 400 to 1000	0.5	32 QFN	Yes	Yes	Yes	—	No	Yes	1.65
TPS59621	D-CAP+	1	2	3/28	0.3/1.5	8	30	Adj. 200 to 500	0.5	40 QFN	Yes	Yes	Yes	—	No	Yes	1.80
TPS59640	D-CAP+	2	4	3/28	0.25/1.52	6	30	Adj. 250 to 500	0.5	48 QFN	Yes	Yes	Yes	—	No	Yes	2.25
TPS59641	D-CAP+	2	4	3/28	0.25/1.52	6	30	Adj. 250 to 500	0.5	48 QFN	Yes	Yes	Yes	—	No	Yes	2.25
TPS59650	D-CAP+	2	5	3/28	0.25/1.52	6	30	Adj. 250 to 600	0.5	48 QFN	Yes	Yes	Yes	—	No	Yes	2.65

Device	Switched Outputs	LDO Outputs	Phases	V <sub>IN</sub> (min/max) (V)	V <sub>O</sub> (min/max) (V)	Driver Current (A)	Output Current (A) <sup>2</sup>	Frequency (kHz)	V <sub>REF</sub> Tol (%)	Control Method	Bootstrap Diode	Package(s)	Overshoot Protection	Power Good	DDR <sup>6</sup>	Price*
<b>DC/DC Synchronous Buck Controllers with Light-Load Efficiency</b>																
TPS51220A	2	2	1	4.5/32	1.0/12.0	2	8	200 to 1000	1	Current or D-CAP™ Mode	Yes	32 QFN	Yes	Yes	No	2.25
TPS51225/B/C	2	2	1	5.5/24	3.3/5.0 <sup>7</sup>	1.7	8	300 to 335	1	D-CAP Mode	Yes	20 QFN	Yes	Yes	No	1.05
TPS51275/C	2	2	1	5.0/24	3.3/5.0 <sup>7</sup>	1.7	7	330 to 335	1	D-CAP Mode	Yes	20 QFN	Yes	Yes	No	1.05
TPS53211	1	0	1	4.5/15	0.8/0.7 x V <sub>IN</sub>	2	25	200 to 600	0.5	Voltage	Yes	16 QFN	Yes	Yes	No	2.00
TPS53219	1	0	1	4.5/28	0.6/5.5	2	25	Select up to 1000	0.5	D-CAP Mode	Yes	16 QFN	Yes	Yes	No	1.35
TPS59116	1	1	1	3/28	1.5/3.0	0.8	10	Up to 400	1	Current, D-CAP Mode	No	20 PowerPAD™, 24 QFN	Yes	Yes	Yes	1.30
TPS59124	2	0	1	3/28	0.76/5.5	3	10	300, 360, 420	1	D-CAP Mode	No	24 QFN	Yes	Yes	No	1.90
TPS59610/11	1	0	1	3/30	0.3/1.5	8	27	200 to 500	0.5	D-CAP+	Yes	32 QFN	Yes	Yes	No	1.40
TPS59621	1	0	2	3/30	0.3/1.5	8	54	250 to 500	0.5	D-CAP+	Yes	40 QFN	Yes	Yes	No	1.80

Device	V <sub>IN</sub> (min/max) (V)	V <sub>O</sub> (min) (V)	Frequency Range (kHz)	f <sub>sync</sub>	On/Off Pin	Topology	Package(s)	Price*
<b>Boost and Buck-Boost Controllers</b>								
LM3430	6.0/40	1.25	50 to 2000	✓	—	Boost	12 LLP	1.00
LM3478	2.95/40	1.26	100 to 1000	✓	✓	Boost, SEPIC, flyback	8 MSOP	0.93
LM3481	2.97/48	1.275	100 to 1000	✓	✓	Boost, SEPIC, flyback	10 MSOP	0.95
LM3488	2.95/40	1.26	100 to 1000	✓	✓	Boost, SEPIC, flyback	8 MSOP	0.99
LM5020	13/100	Set by external feedback network		50 to 1000	✓	Flyback, inverting, buck, boost, forward	10 MSOP, 10 LLP	0.99
LM5021	8.0/30	Set by external feedback network		50 to 1000	✓	Flyback, forward	8 MSOP	0.66
LM5022/C	6.0/60	1.25	50 to 2000	✓	✓	Boost, SEPIC	10 MSOP	1.13
LM(2)5118	3.0/(42/75)	1.23	50 to 500	✓	✓	Buck-boost	20 eTSSOP	2.00/2.38
TPS40210/1 <sup>8</sup>	4.5/52	5	Adj. to 1000	✓	✓	Boost, SEPIC, flyback	10 MSSOP/SON	1.10
TPS43000 <sup>9</sup>	1.8/9	0.8	Adj. to 2000	✓	✓	Boost, SEPIC, flyback	16 TSSOP	2.25
TPS43060 <sup>9</sup>	4.5/38	0.8	50 to 1000	✓	✓	Synchronous boost (60 V)	3x3-mm QFN	1.40

<sup>1</sup>C = Current-feedback control and VFF = voltage mode with voltage feed-forward compensation.

<sup>2</sup>Current levels of this magnitude can be supported with commonly available commercial FETs.

<sup>3</sup>The controller of choice for most applications will be the source/sink version, which has two-quadrant operation and will source or sink output current.

<sup>4</sup>Stackable to 16 phases.

<sup>5</sup>Stackable to 8 phases, reference is trimmable.

<sup>6</sup>DDR = Supports DDR memory.

<sup>7</sup>Fixed range: OUT1 = 5.0 V ±10% and OUT2 = 3.3 V ±10%.

<sup>8</sup>Overshoot protection, source only.

<sup>9</sup>External synch pin.

\*Suggested resale price in U.S. dollars in quantities of 1,000.

**New devices are listed in bold red.**

# DC/DC Switching Regulators

## Charge Pumps

### Inductorless DC/DC Regulators (Charge Pumps) Family of Products

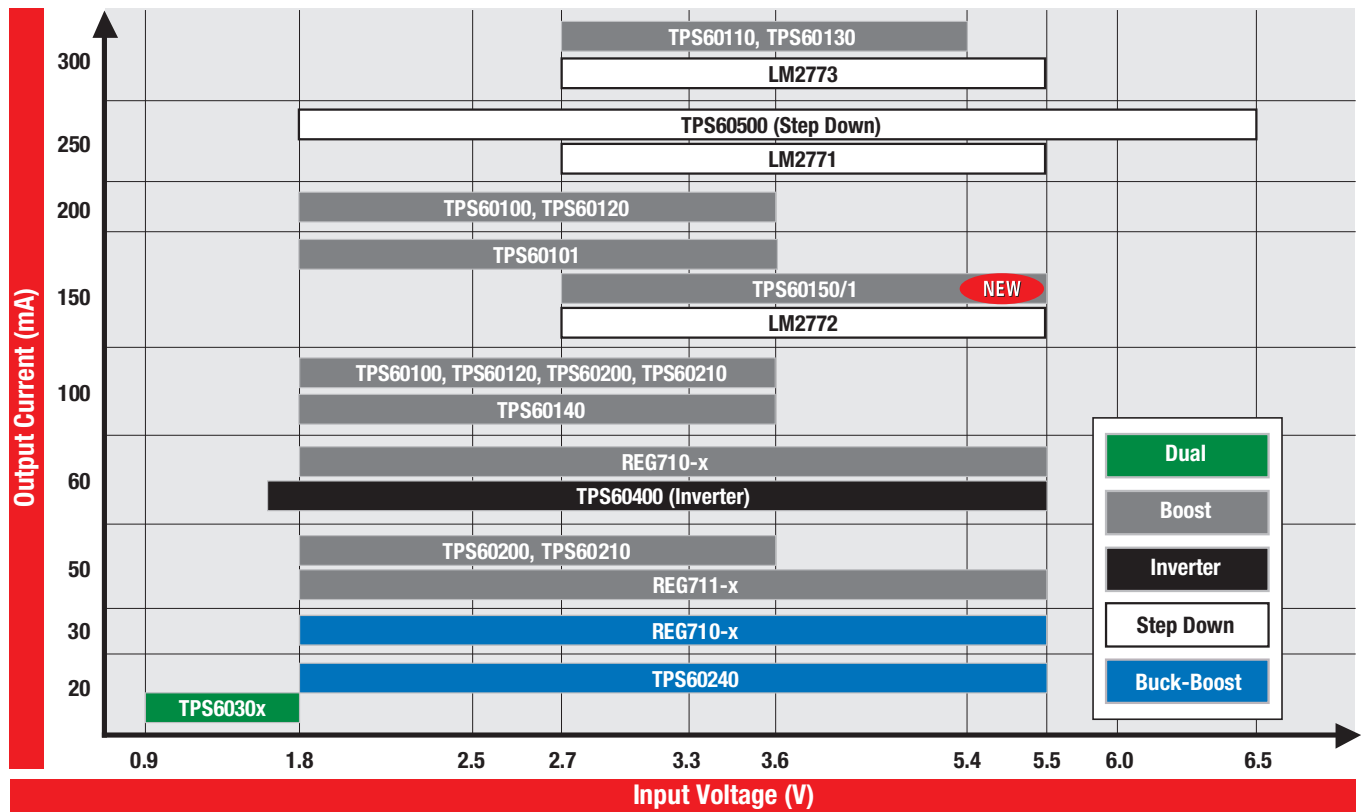

## Selection Guide

Device	I <sub>OUT</sub> (mA)	V <sub>IN</sub> (V)	V <sub>OUT</sub> Adj. (V)	V <sub>OUT</sub> Fixed (V)	Efficiency (%)	Switching Frequency (max) (kHz)	Quiescent Current (typ) (μA)	Shutdown Current (typ) (μA)	Features						Package(s)	EVM	Price*
									Shutdown	Low Battery	Power Good	Undervoltage Lockout	Current Limit	Thermal Limit			
<b>Step-Down (Buck) Regulators</b>																	
LM2772	150	2.7 to 5.5	—	1.2	—	1100	45	—	✓						QFN-10	✓	0.75
TPS60500	250	1.8 to 6.5	0.8 to 3.3	1.5, 1.8, 3.3	90	1200	40	0.05	✓		✓	✓	✓	✓	MSOP-10	✓	0.55
LM2771	250	2.7 to 5.5	—	1.5	—	1100	45	—	✓						QFN-10		0.85
LM2773	300	2.5 to 5.5	1.6 to 1.8	—	—	1150	48	—	✓						micro SMD-9	✓	0.90
<b>Boost Regulators</b>																	
TL7660	20	1.5 to 10	—	< 2V <sub>IN</sub>	99	10.35	80	—							SOT-23, MSOP-8		0.80
TPS6020x	50, 100 <sup>1</sup>	1.8 to 3.6	—	3.3	90	400	40	0.05	✓	✓ <sup>1</sup>	✓ <sup>1</sup>	✓			MSOP-10		0.65
TPS6021x	50, 100 <sup>1</sup>	1.8 to 3.6	—	3.3	90	400	35	2	Snooze	✓ <sup>1</sup>	✓ <sup>1</sup>	✓			MSOP-10		0.65
TPS60101	100	1.8 to 3.6	—	3.3	90	300	50	0.05	✓			✓	✓		TSSOP-20		0.65
TPS6012x	100, 200 <sup>1</sup>	1.8 to 3.6	—	3.0, 3.3 <sup>1</sup>	85	450	55	0.05	✓	✓ <sup>1</sup>	✓ <sup>1</sup>	✓	✓		TSSOP-20		0.65, 0.80 <sup>1</sup>
TPS6014x	100	1.8 to 3.6	—	5.0	70	450	65	0.05	✓	✓ <sup>1</sup>	✓ <sup>1</sup>	✓	✓		TSSOP-20	✓	0.65
TPS6020x	100	1.8 to 3.6	—	3.3	90	400	35	0.05	✓	✓ <sup>1</sup>	✓ <sup>1</sup>	✓			MSOP-10	✓	0.65
TPS60210	100	1.8 to 3.6	—	3.3	90	400	35	2	Snooze	✓ <sup>1</sup>	✓ <sup>1</sup>	✓			MSOP-10	✓	0.65
TPS60150	140	2.7 to 5.5	—	5.0	90	1500	4.7	0.01	✓					✓	QFN-6	✓	0.50
TPS60111	150	2.7 to 5.4	—	5.0	90	300	60	0.05	✓			✓	✓		TSSOP-20		0.70
TPS6013x	150, 300 <sup>1</sup>	2.7 to 5.4	—	5.0	90	450	60	0.05	✓	✓ <sup>1</sup>	✓ <sup>1</sup>	✓			TSSOP-20		0.70, 0.80 <sup>1</sup>
TPS60100	200	1.8 to 3.6	—	3.3	90	300	50	0.05	✓			✓	✓		TSSOP-20	✓	0.65
TPS60110	300	2.7 to 5.4	—	5.0	90	300	60	0.05	✓			✓	✓		TSSOP-20	✓	0.80

<sup>1</sup> Device parameter, feature and/or price may vary with each device number in family.  
 \*Suggested resale price in U.S. dollars in quantities of 1,000.

# DC/DC Switching Regulators

## Charge Pumps

### Selection Guide (Continued)

Device	I <sub>OUT</sub> (mA)	V <sub>IN</sub> (V)	V <sub>OUT</sub> Adj. (V)	V <sub>OUT</sub> Fixed (V)	Efficiency (%)	Switching Frequency (max) (kHz)	Quiescent Current (typ) (μA)	Shutdown Current (typ) (μA)	Features						Package(s)	EVM	Price*
									Shutdown	Low Battery	Power Good	Undervoltage Lockout	Current Limit	Thermal Limit			
<b>Dual-Output Regulators</b>																	
TPS6030x	20, 40	0.9 to 1.8	—	3.0, 3.3, 2V <sub>IN</sub> <sup>1</sup>	90	900	35	1	✓		✓	✓			MSOP-10	✓	0.70
TPS6031x	20, 40	0.9 to 1.8	—	3.0, 3.3, 2V <sub>IN</sub> <sup>1</sup>	90	900	35	2	Snooze		✓	✓			MSOP-10		0.65
<b>Buck-Boost Regulators</b>																	
REG710	30	1.8 to 5.5	—	2.5, 2.7, 3, 3.3, 5	90	1000	65	0.01	✓				✓	✓	SOT-23		0.45
REG71050	60	2.7 to 5.5	—	5.0	90	1000	65	0.01	✓				✓	✓	SOT-23	✓	0.50
REG711	50	1.8 to 5.5	—	2.5, 2.7, 3, 3.3, 5	90	1000	60	0.01	✓				✓	✓	MSOP-8		0.48
TPS60240	12	1.8 to 5.5	—	3.3	90	160	25	0.1					✓	✓	MSOP-8		0.55
<b>Inverting Regulators</b>																	
TPS60400	60	1.6 to 5.5	-16.6 to -5.25	—	99	50 to 250	125	—							SOT-23	✓	0.33
TPS60401	60	1.6 to 5.5	-16.6 to -5.25	—	99	20	70	—							SOT-23		0.33
TPS60402	60	1.6 to 5.5	-16.6 to -5.25	—	99	50	275	—							SOT-23		0.33
TPS60403	60	1.6 to 5.5	-16.6 to -5.25	—	99	250	400	—							SOT-23		0.33

<sup>1</sup>Device parameter, feature and/or price may vary with each device number in family.

\*Suggested resale price in U.S. dollars in quantities of 1,000.



# RF Power Solutions

## Overview

### RF Front End Power Solutions for 2G, 3G and 4G Portable Devices

Operation of the radio circuitry in a portable device accounts for a significant amount of the total power consumption—leading to less battery life and more heat. Traditionally, the RF power amplifier (PA), which is used to drive the antenna, is connected directly to the battery. However, this approach wastes a significant amount of energy as the

PA is supplied with maximum power when often only a fraction is required to reliably ensure wireless voice and data connection. TI's portfolio of RF power management products delivers energy and heat saving solutions that enable higher performing RFFE systems. Supply for Power Amplifier products are dynamically adjustable power supplies for RF power amplifiers that optimize power usage—especially when maximum PA power is not needed—to extend battery

life and reduce heat dissipation. TI's family of RF detectors provides transmit power control so that only the necessary amount of power is used, saving power and increasing transmission range. These RF detectors feature high linearity and accuracy over temperature to reduce PA power guard-band requirements for more coverage range, battery power savings, and increased channel quality.

Get more information: [www.ti.com/rfpower](http://www.ti.com/rfpower)

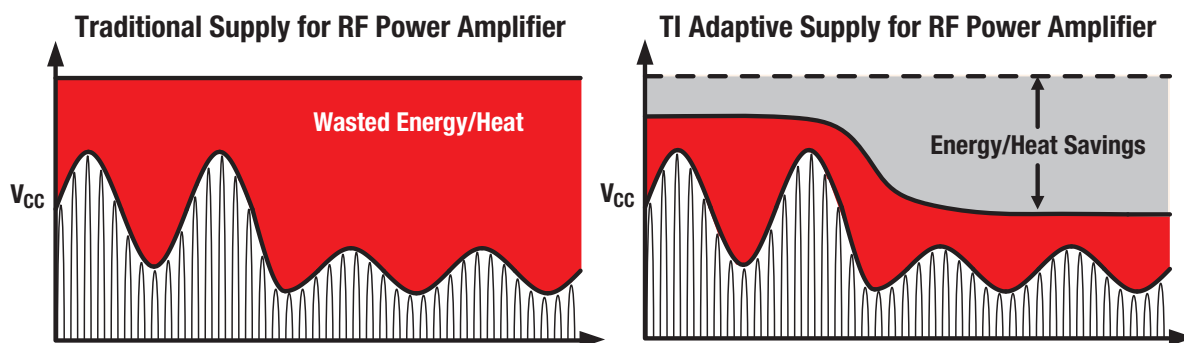
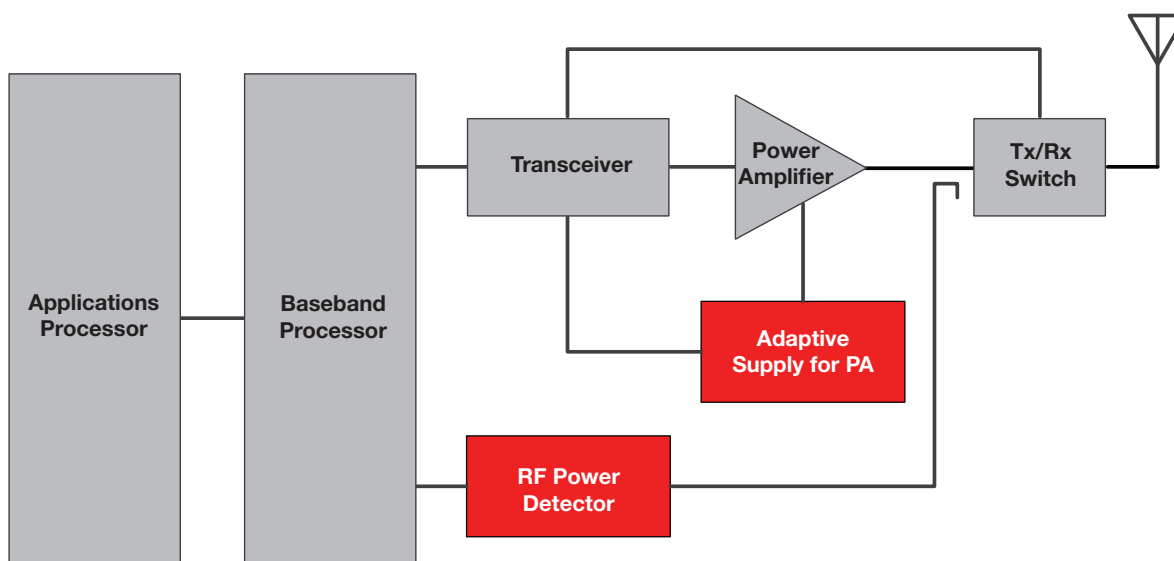

RF power solutions from TI enable efficient RF front-end designs.

# RF Power Solutions

## RF DC/DC Converters

### 6-MHz, 750-mA Miniature, Adjustable, Step-Down Converter for 3G/4G RF Power Amplifiers

#### LM3242

TI's Supply for Power Amplifier products are dynamic power supplies for RF power amplifiers. Converters like the LM3242 enable active adjustment of the power delivered to the RF power amplifier in order to optimize the power usage—especially when maximum power is not required—to drastically increase efficiency. These energy savings extend battery life for more talk and data usage time and reduce heat dissipation by up to 30°C for a more reliable, easier-to-design system.

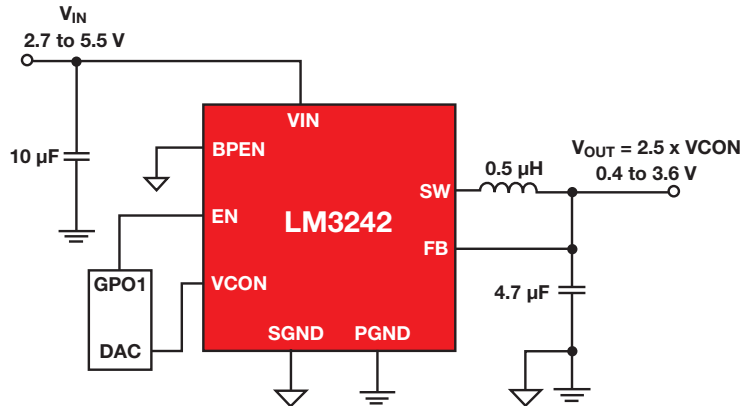

LM3242 application circuit with just three tiny surface-mount components.

#### Key Features

- Operates from a single Li-Ion cell (2.7 to 5.5 V)
- Adjustable output voltage (0.4 to 3.6 V) maximizes RF PA power savings
- 750-mA maximum load capability (up to 1 A in bypass) increases performance reliability during transients
- 6-MHz (typ) PWM switching frequency minimizes inductor footprint
- Automatic ECO/PWM/BP mode change for optimal operation during all load requirements and battery conditions
- Current and thermal overload protection
- Small solution size

#### Thermal Imaging—RF Power Amplifier

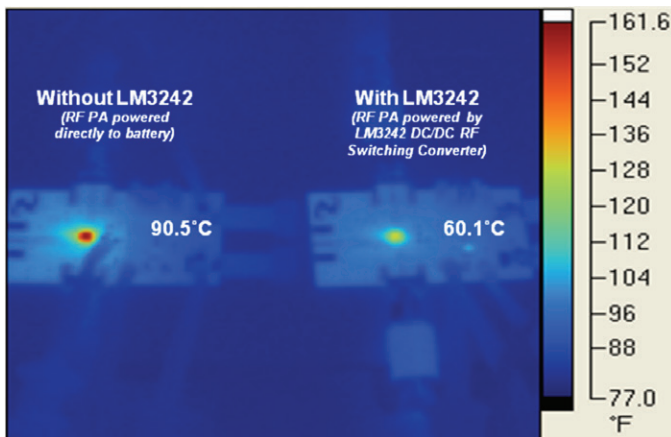

LM3242 reduces PA heat by 30°C at maximum RF power (28 dBm).

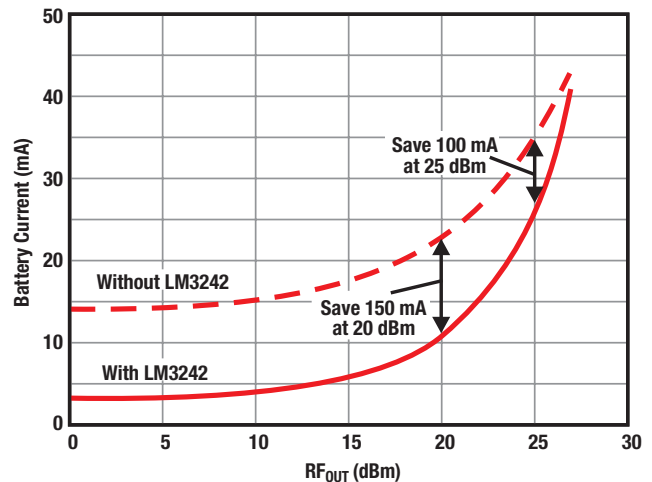

LM3242 extends battery life with dramatically reduced current consumption.

Get more information: [www.ti.com/product/LM3242](http://www.ti.com/product/LM3242)

### RF DC/DC Switching Converters with Adjustable Output Power for RF Power Amplifiers

Device	Topology	V <sub>IN</sub> (V)	V <sub>OUT</sub> (V)	I <sub>OUT</sub> (max) (mA)	Bypass Modes	Soft Start	Switching Frequency (MHz)	Package(s)	Description/Features	Price*
LM3209-G3	Buck-Boost	2.7 to 5.5	0.6 to 4.2	1000	None	No	2.4	12-bump micro SMD		0.90
LM3269	Buck-Boost	2.7 to 5.5	0.6 to 3.8	1000	None	No	2.4	12-bump micro SMD		0.75
LM3212	Buck	2.7 to 5.5	0.5 to 3.4	2500	Forced and Active	No	1.6	16-bump micro SMD		1.10
TPS62730	Buck	1.9 to 3.9	1.9/2.1/2.3	100	Active	Yes	3	6-QFN (1x1.5 mm)	BLE, RF4CE	0.75
LM3241	Buck	2.7 to 5.5	0.6 to 3.4	750	None	Yes	6	6-bump micro SMD		0.40
LM3242	Buck	2.7 to 5.5	0.4 to 3.6	750	Forced and Auto	Yes	6	9-bump micro SMD		0.37
LM3262	Buck	2.5 to 5.5	0.4 to 3.6	800	Forced and Auto	Yes	6	9-bump micro SMD		0.40
LM3243	Buck	2.7 to 5.5	0.4 to 3.6	2500	Forced and Active	No	2.7	16-bump micro SMD		0.45

\*Suggested resale price in U.S. dollars in quantities of 1,000.

# RF Power Solutions

## RF Power Detectors

### 8-GHz LOG/LIN RMS RF Power Detector

#### LMH2110, LMH2120

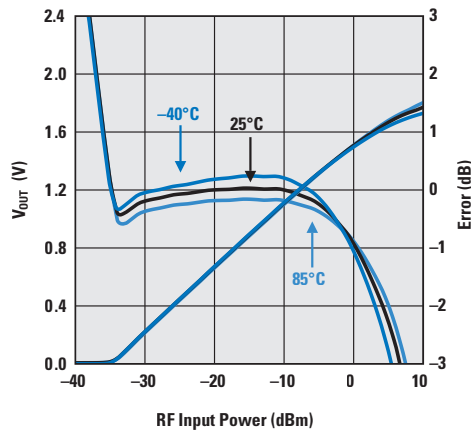

#### Key Features

- LMH2110: 40-dB linear-in-dB power detection range
- LMH2120: 40-dB linear-in-V power detection range
- > 30-dB dynamic range, 1900 MHz,  $n = 50$ 
  - $\pm 0.3$ -dB log conformance error
  - $\pm 0.3$ -dB variation over temperature
  - 0.05-dB (typ) output variation due to modulation, WCDMA

- Shutdown pin
- Multi-band operation from 50 MHz up to 8 GHz
- Available in micro SMD-6 packaging (0.84 x 1.24 mm)

Get more information: [www.ti.com/product/LMH2110](http://www.ti.com/product/LMH2110) or [LMH2120](http://www.ti.com/product/LMH2120)

### 50-MHz to 4-GHz 40-dB Logarithmic Power Detector for CDMA and WCDMA

#### LMV221, LMH2100

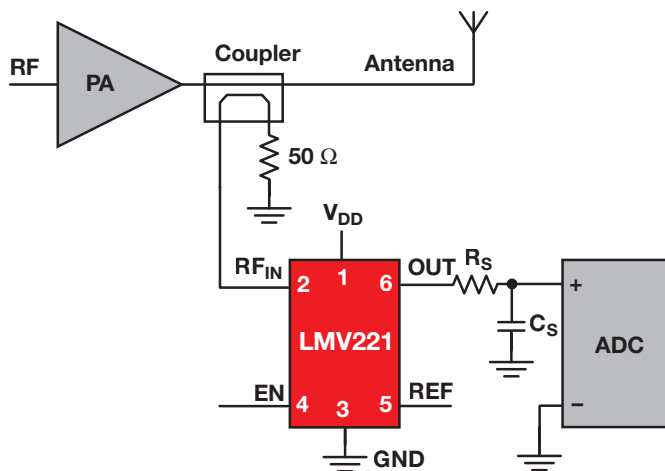

Typical application circuit.

#### Key Features

- 40-dB linear-in-dB power detection range
- 0.3-V to 2-V output voltage range
- Shutdown pin
- Multi-band operation from 50 MHz to 3.5 GHz
- 0.5-dB accurate temperature compensation
- External configurable output filter bandwidth
- Available in LLP-6 packaging, 2.2 x 2.5 x 0.8 mm (LMV221)
- Available in micro SMD-6 packaging, 0.85 x 1.25 x 0.6 mm (LMH2100)

Get more information: [www.ti.com/product/LMV221](http://www.ti.com/product/LMV221) or [LMH2100](http://www.ti.com/product/LMH2100)

## RF Power Detectors

Device	Application	Channels	Supply Voltage Range (V)	Dynamic Range (dB)	Frequency Range (MHz)	Type	Package(s)	EVM	Price*
LMV221	CDMA, WCDMA, GSM, GPRS	1	2.7 to 3.3	40	50 to 3500	LOG Amp	LLP-6	✓	0.90
LMV225	CDMA, WCDMA, GSM, EDGE, GPRS, TDMA	1	2.7 to 5.5	>30	450 to 2000	LOG Amp	micro SMD-4, LLP-6	✓	0.32
LMV226	CDMA, WCDMA, GSM, EDGE, GPRS, TDMA	1	2.7 to 5.5	>30	450 to 2000	LOG Amp	micro SMD-4	✓	0.42
LMV228	CDMA, WCDMA, GSM, EDGE, GPRS, TDMA	1	2.7 to 5.5	>30	450 to 2000	LOG Amp	micro SMD-4	✓	0.36
LMV232	3G, UMTS, WCDMA, CDMA2000, LAN, GPS	2	2.5 to 3.3	20	50 to 2000	LIN MS Amp	micro SMD-8	✓	0.85
LMV242	GSM, GPRS, TDMA, LAN	2	2.6 to 5.5	50	450 to 2000	LOG Amp	LLP-10	✓	0.55
LMH2100	CDMA, WCDMA, GSM, GPRS	1	2.7 to 3.3	40	50 to 4000	LOG Amp	micro SMD-6	✓	0.95
LMH2110	LTE, UMTS, WCDMA, CDMA2000, GSM/EDGE	1	2.7 to 5	45	50 to 8000	LOG RMS	micro SMD-6	✓	0.80
LMH2120	LTE, UMTS, WCDMA, CDMA2000, GSM/EDGE	1	2.7 to 5	40	50 to 6000	LIN RMS	micro SMD-6	✓	0.80
LMH2121	LTE, UMTS, WCDMA	1	2.7 to 5	40	100 to 3000	Fast LIN Amp	micro SMD-4	✓	0.60

\*Suggested resale price in U.S. dollars in quantities of 1,000.

# NexFET™ Power MOSFETs

TI's premier power management innovation called NexFET™ technology combines vertical current flow with a lateral power MOSFET. It provides a low on-resistance and requires an extremely low gate charge with industry-standard package outlines—a combination not previously possible with existing silicon platforms.

NexFET technology delivers high performance for both N- and P-channel power MOSFET devices. Designers are able to achieve 90% power supply efficiencies from light to full loads with high output currents and low duty cycles, representing a breakthrough in discrete designs.

	NexFET™ Technology	Industry Standard
Control FET	$R_{DS(on)} = 5.8 \text{ m}\Omega$	$R_{DS(on)} = 6.6 \text{ m}\Omega$
	$Q_G = 6.5 \text{ nC}$	$Q_G = 12.3 \text{ nC}$
Sync FET	$R_{DS(on)} = 2.5 \text{ m}\Omega$	$R_{DS(on)} = 2.3 \text{ m}\Omega$
	$Q_G = 13.2 \text{ nC}$	$Q_G = 39.8 \text{ nC}$

## 90% Efficiency from Light to Full Load

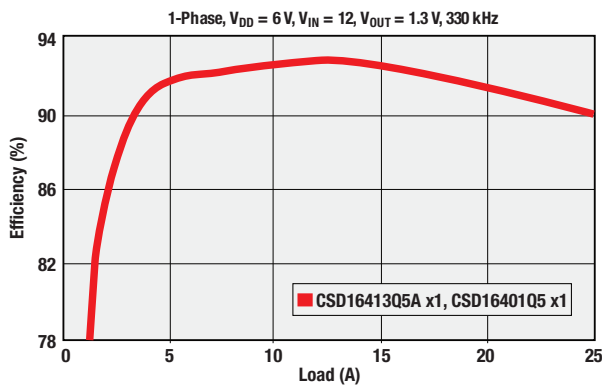

## Same Power Loss, Double the Frequency

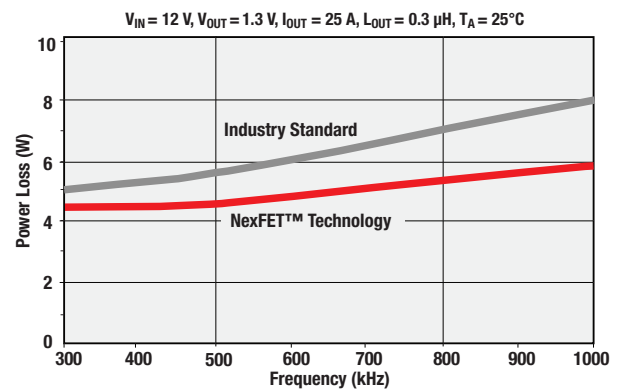

## System Block Diagram of TI Electronics in a Power System Design

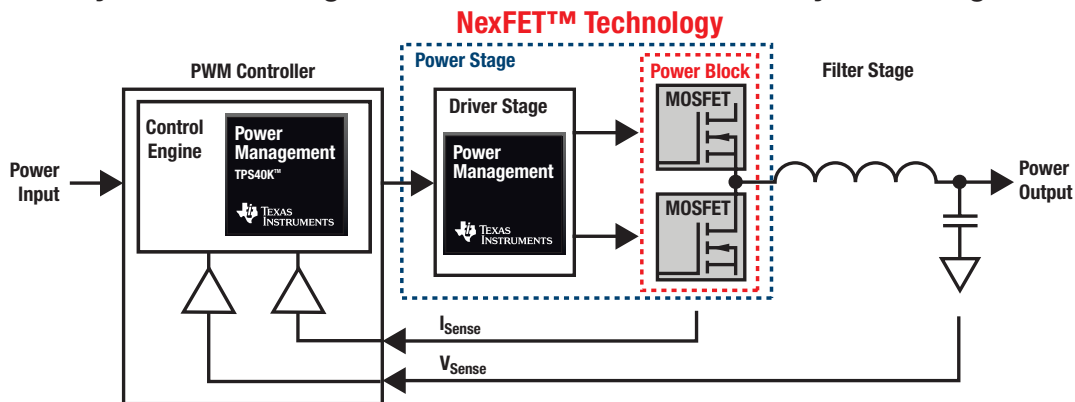

## Selection Guide

Device	Channel	$V_{DS}$ (V)	$V_{GS}$ (V)	Typical $V_{GS(th)}$ (V)	Typical $R_{DS(on)}$ (m $\Omega$ )						Maximum $I_D$ (A)	Typical $Q_G$ at 4.5 V (nC)	Typical $Q_{GS}$ (nC)	Typical $Q_{GD}$ (nC)	Typical $R_G$ ( $\Omega$ )	Price*
					at 10 V	at 4.5 V	at 3 V	at 2.5 V	at 1.8 V	at 1.5 V						
<b>WLP 1x1</b>																
<b>Single</b>																
<b>CSD23201W10</b>	P	12	6	0.6	—	66	—	77	—	110	2.2	1.9	0.28	0.26	—	0.20
<b>WLP 1x1.5</b>																
<b>Single</b>																
<b>CSD25211W1015</b>	P	20	6	0.80	—	27	—	36	—	—	3.2	3.4	1.1	0.2	—	0.25
CSD25301W1015	P	20	8	0.75	—	62	—	80	—	175	2.2	1.9	0.35	0.4	—	0.25
CSD25303W1015	P	20	8	0.75	—	46	—	56	—	72	3	3.3	0.6	0.6	—	0.25
<b>Common Source</b>																
CSD75205W1015	P	20	6	0.65	—	95	—	115	145	—	1.2	1.6	0.3	0.4	—	0.26
CSD75301W1015	P	20	8	0.7	—	80	—	105	150	—	1.2	1.5	0.28	0.3	—	0.26

\*Suggested resale price in U.S. dollars in quantities of 1,000.

New devices are listed in bold red.

# NexFET™ Power MOSFETs

## Selection Guide (Continued)

Device	Channel	V <sub>DS</sub> (V)	V <sub>GS</sub> (V)	Typical V <sub>GS(th)</sub> (V)	Typical R <sub>DS(on)</sub> (mΩ)						Maximum I <sub>D</sub> (A)	Typical Q <sub>G</sub> at 4.5 V (nC)	Typical Q <sub>GS</sub> (nC)	Typical Q <sub>GD</sub> (nC)	Typical R <sub>G</sub> (Ω)	Price*
					at 10 V	at 4.5 V	at 3 V	at 2.5 V	at 1.8 V	at 1.5 V						
<b>WLP 1.5x1.5</b>																
<b>Single</b>																
CSD25201W15	P	20	6	0.7	—	33	—	42	52	—	4	4.3	1	0.7	—	0.28
<b>Common Source</b>																
CSD75204W15	P	20	6	0.7	—	80	—	105	140	—	3	2.8	0.5	0.6	—	0.30
<b>WLP 1.7x2.3</b>																
<b>Dual</b>																
CSD86311W1723	N	25	10	1	—	31	—	37	—	—	4.5	2.8	0.7	0.6	—	0.43
CSD75211W1723	P	20	8	0.7	—	32	—	61	80	—	4.5	4.5	0.9	0.9	—	0.43
<b>SON 2x2</b>																
<b>Single</b>																
CSD16301Q2	N	25	10	1.1	—	23	27	—	—	—	5	2	0.6	0.4	1.3	0.15
CSD17313Q2	N	30	10	1.3	—	26	31	—	—	—	5	2.1	0.7	0.4	1.3	0.15
CSD25302Q2	P	20	8	0.65	—	39	—	56	71	—	5	2.6	0.54	0.5	—	0.15
<b>SON 3x3</b>																
<b>Single</b>																
CSD16411Q3	N	25	16	2	8	12	—	—	—	—	56	2.9	1.5	0.7	0.8	0.30
CSD16409Q3	N	25	16	2	6.2	9.5	—	—	—	—	60	4	2.1	1	0.9	0.33
CSD16406Q3	N	25	16	1.8	4.2	5.9	—	—	—	—	60	5.8	2.5	1.5	1.2	0.33
CSD16323Q3	N	25	10	1.1	—	4.4	5.4	—	—	—	60	6.2	1.8	1.1	1.4	0.39
CSD16327Q3	N	25	10	1.1	—	4	—	—	—	—	60	6.2	1.8	1.1	1.4	0.39
<b>CSD16340Q3</b>	N	25	10	0.85	—	4.3	—	6.1	—	—	60	6.5	2.1	1.2	1.5	0.39
CSD17308Q3	N	30	10	1.3	—	9.4	12.5	—	—	—	47	3.9	1.3	0.8	0.9	0.30
CSD17304Q3	N	30	10	1.3	—	6.9	9.8	—	—	—	56	5.1	1.8	1.1	1.1	0.32
CSD17309Q3	N	30	10	1.2	—	4.9	6.3	—	—	—	60	7.5	2.5	1.7	1.2	0.39
<b>CSD17551Q3A</b>	N	30	20	1.60	7.8	9.6	—	—	—	—	48	6.0	2.3	1.5	1.5	0.24
<b>CSD17552Q3A</b>	N	30	20	1.50	5.5	6.5	—	—	—	—	60	9.0	3.6	2.3	0.9	0.27
<b>CSD87312Q3E</b>	N	30	10	1.00	27	31	—	—	—	—	27	6.3	1.9	0.7	5.0	0.35
CSD25401Q3	P	20	12	0.85	—	8.8	—	13.5	—	—	60	8.8	2.1	2.1	1.2	0.41
<b>SON 5x6</b>																
<b>Single</b>																
CSD16412Q5A	N	25	16	2	9	13	—	—	—	—	52	2.9	1.4	0.7	0.7	0.30
CSD16410Q5A	N	25	16	1.9	6.8	9.6	—	—	—	—	59	3.9	1.8	1.1	0.7	0.32
CSD16404Q5A	N	25	16	1.8	4.1	5.7	—	—	—	—	81	6.5	3	1.7	0.9	0.39
CSD16408Q5	N	25	16	1.8	3.6	5.4	—	—	—	—	113	6.7	3.1	1.9	0.8	0.45
CSD16413Q5A	N	25	16	1.6	3.1	4.1	—	—	—	—	100	9	3.5	2.5	0.9	0.44
CSD16403Q5A	N	25	16	1.6	2.2	2.9	—	—	—	—	100	13.3	5.5	3.5	1.2	0.60
CSD16407Q5	N	25	16	1.6	1.8	2.5	—	—	—	—	100	13.3	5.3	3.5	1.2	0.65
CSD16414Q5	N	25	16	1.6	1.5	2.1	—	—	—	—	100	16.6	7.3	4.4	1.4	0.75
CSD16401Q5	N	25	16	1.5	1.3	1.8	—	—	—	—	100	21	8.3	5.2	1.2	0.95
CSD16322Q5	N	25	10	1.1	—	4.6	5.4	—	—	—	97	6.8	2.4	1.3	1.1	0.41
CSD16321Q5	N	25	10	1.1	—	2.1	2.8	—	—	—	100	14	4	2.5	1.5	0.65
CSD16325Q5	N	25	10	1.1	—	1.7	2.1	—	—	—	100	18	6.6	3.5	1.6	0.95
CSD16342Q5A	N	25	10	0.85	—	4.3	—	6.1	—	—	60	6.5	2.1	1.2	1.5	0.42
<b>CSD16556Q5B</b>	N	25	20	1.40	0.9	1.2	—	—	—	—	100	36	11	12	0.7	0.81
CSD17307Q5A	N	30	10	1.3	—	9.7	12.8	—	—	—	73	4	1.3	1	0.9	0.30
CSD17302Q5A	N	30	10	1.2	—	7.3	9.5	—	—	—	87	5.4	1.7	1.2	0.8	0.32
CSD17310Q5A	N	30	10	1.3	—	4.5	5.7	—	—	—	100	8.9	2.7	2.1	0.9	0.39
CSD17306Q5A	N	30	10	1.1	—	3.3	4.2	—	—	—	100	11.8	3.5	2.4	1	0.44
CSD17305Q5A	N	30	10	1.1	—	2.8	3.9	—	—	—	100	14.1	4.5	3	1	0.49
CSD17301Q5A	N	30	10	1.1	—	2.3	2.9	—	—	—	100	19	5.7	4.3	1.3	0.60

\*Suggested resale price in U.S. dollars in quantities of 1,000.

New devices are listed in bold red.

# NexFET™ Power MOSFETs

## Selection Guide (Continued)

Device	Channel	V <sub>DS</sub> (V)	V <sub>GS</sub> (V)	Typical V <sub>GS(th)</sub> (V)	Typical R <sub>DS(on)</sub> (mΩ)						Maximum I <sub>D</sub> (A)	Typical Q <sub>G</sub> at 4.5 V (nC)	Typical Q <sub>GS</sub> (nC)	Typical Q <sub>GD</sub> (nC)	Typical R <sub>G</sub> (Ω)	Price*
					at 10 V	at 4.5 V	at 3 V	at 2.5 V	at 1.8 V	at 1.5 V						
<b>SON 5x6 (Continued)</b>																
<b>Single (Continued)</b>																
CSD1730Q5	N	30	10	1.1	—	2	2.7	—	—	—	100	18	5.6	4	1.4	0.65
CSD1731Q5	N	30	10	1.2	—	1.8	2.3	—	—	—	100	24	6.6	5.2	1.2	0.75
CSD1731Q5	N	30	10	1.1	—	1.4	1.8	—	—	—	100	28	8.4	6	1.1	0.95
CSD17501Q5A	N	30	20/–20	1.3	2.4	3	—	—	—	—	187	13.2	5.4	3.5	—	0.60
CSD17505Q5A	N	30	20/–20	1.3	2.9	3.7	—	—	—	—	153	10	3.5	2.7	—	0.49
CSD17506Q5A	N	30	20/–20	1.3	3.2	4.2	—	—	—	—	150	8.3	3.1	2.3	—	0.44
CSD17507Q5A	N	30	20/–20	1.6	9	11.8	—	—	—	—	85	2.8	1.3	0.7	—	0.30
CSD17510Q5A	N	30	20/–20	1.5	4.1	5.4	—	—	—	—	129	6.4	2.7	1.9	—	0.39
CSD17322Q5A	N	30	10	1.6	—	10	—	—	—	—	87	3.6	1.6	1.1	4.7	0.32
CSD17327Q5A	N	30	10	1.6	—	12.5	—	—	—	—	65	2.8	1.2	0.8	4.7	0.30
CSD17527Q5A	N	30	20/–20	1.6	—	12.5	—	—	—	—	65	2.8	1.2	0.8	4.7	0.30
CSD17522Q5A	N	30	20/–20	1.6	—	10	—	—	—	—	87	3.6	1.6	1.1	4.7	0.32
<b>CSD17551Q5A</b>	N	30	20	1.70	7.0	9.0	—	—	—	—	48	6.0	2.8	1.4	1.4	0.26
<b>CSD17552Q5A</b>	N	30	20	1.60	5.1	6.1	—	—	—	—	60	9.0	3.6	2.0	0.9	0.29
<b>CSD17553Q5A</b>	N	30	20	1.50	2.7	3.5	—	—	—	—	100	17.5	5.8	4.7	0.7	0.36
<b>CSD17555Q5A</b>	N	30	20	1.50	2.3	2.8	—	—	—	—	100	23	7.5	5.0	0.8	0.46
<b>CSD17559Q5</b>	N	30	20	1.40	0.95	1.15	—	—	—	—	100	39	14.4	9.3	1.2	0.92
<b>CSD18501Q5A</b>	N	40	20	1.8	2.5	3.3	—	—	—	—	155	20	8.1	5.9	1.2	0.80
<b>CSD18502Q5B</b>	N	40	20	1.8	3.4	4.7	—	—	—	—	145	13	4.5	4.3	1.2	0.65
<b>CSD18503Q5A</b>	N	40	20	1.8	1.8	2.5	—	—	—	—	204	25	10.3	8.4	1.2	1.01
<b>CSD18504Q5A</b>	N	40	20	1.9	5.3	7.5	—	—	—	—	75	7.7	3.2	2.4	1.4	0.50
<b>CSD18531Q5A</b>	N	60	20	1.8	3.5	4.4	—	—	—	—	134	18	6.9	5.9	1.2	0.80
<b>CSD18532Q5B</b>	N	60	20	1.8	2.5	3.3	—	—	—	—	172	21	6.3	10	1.2	1.01
<b>CSD18533Q5A</b>	N	60	20	1.9	4.7	6.5	—	—	—	—	77	14	6.6	5.4	1.3	0.63
<b>CSD18534Q5A</b>	N	60	20	1.9	7.8	9.9	—	—	—	—	69	8.5	3.2	3.5	1.5	0.50
<b>TO-220</b>																
<b>Single</b>																
<b>CSD18502KCS</b>	N	40	20	1.8	3.4	3.3	—	—	—	—	200	25	10.3	8.4	1.2	0.97
<b>CSD18503KCS</b>	N	40	20	1.9	3.6	5.4	—	—	—	—	130	15	7.7	4.6	1.4	0.71
<b>CSD18504KCS</b>	N	40	20	1.9	5.5	8	—	—	—	—	85	9.2	4.4	3.5	1.5	0.58
<b>CSD18532KCS</b>	N	60	20	1.8	3.3	4.2	—	—	—	—	169	21	10	6.9	1.3	0.97
<b>CSD18533KCS</b>	N	60	20	1.9	5	6.9	—	—	—	—	114	14	9.4	3.9	1.4	0.71
<b>CSD18534KCS</b>	N	60	20	1.9	7.6	10.2	—	—	—	—	71	93	4.8	3.1	1.5	0.58
<b>DualCool™ SON 5x6</b>																
<b>Single</b>																
CSD16408Q5C	N	25	16	1.8	3.6	5.4	—	—	—	—	113	6.7	3.1	1.9	0.8	0.49
CSD16407Q5C	N	25	16	1.6	1.8	2.5	—	—	—	—	100	13.3	5.3	3.5	1.2	0.75
CSD16322Q5C	N	25	10	1.1	—	4.6	5.4	—	—	—	97	6.8	2.4	1.3	1.1	0.45
CSD16321Q5C	N	25	10	1.1	—	2.1	2.8	—	—	—	100	14	4	2.5	1.5	0.75
CSD16325Q5C	N	25	10	1.1	—	1.7	2.1	—	—	—	100	18	6.6	3.5	1.6	1.05
<b>DualCool SON 3x3</b>																
<b>Single</b>																
CSD16323Q3C	N	25	10	1.1	—	4.6	5.4	—	—	—	60	6.2	1.8	1.1	1.4	0.43

\*Suggested resale price in U.S. dollars in quantities of 1,000.

New devices are listed in bold red.

# NexFET™ Power MOSFETs

**CSD8xxx NexFET™ Power Block**  
contains two MOSFETs in TI's  
PowerStack™ package

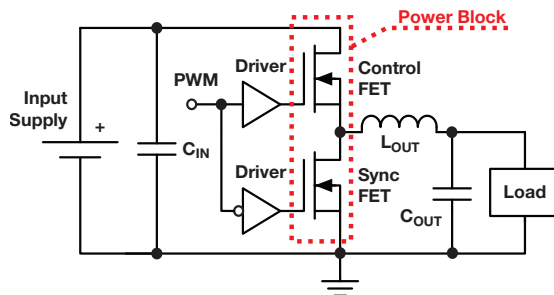

**CSD9xxx NexFET Power Stage** integrates  
enhanced gate drivers with two MOSFETs  
in TI's PowerStack™ package

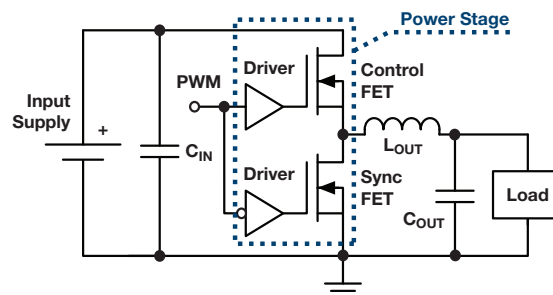

## Selection Guide

Device	Channel	Integrated Driver	V <sub>DS</sub> (V)	V <sub>GS</sub> (V)	Power Loss (W)	P <sub>loss</sub> Current (A)	Max Current (A)	Max f <sub>SW</sub> (MHz)	High Duty Cycle Applications	Price*
<b>SON 3x3 Power Block</b>										
CSD87330Q3D	N	No	30	10	2	15	20	1.5	No	0.75
CSD87331Q3D	N	No	30	10	1.3	10	15	1.5	No	0.65
<b>SON 5x6 Power Block and SON 5x6 Power Stage</b>										
CSD86360Q5D	N	No	25	10	2.6	25	50	1.5	No	1.15
CSD87350Q5D	N	No	30	10	3	25	40	1.5	No	1.05
CSD87351Q5D	N	No	30	10	2.5	20	32	1.5	No	0.95
CSD87352Q5D	N	No	30	10	1.8	15	25	1.5	No	1.00
CSD87353Q5D	N	No	30	10	3.3	25	120	1.5	Yes	1.50
CSD96370Q5M	N	Yes	25	—	2.6	25	40	2.0	—	1.35
CSD96371Q5M	N	Yes	25	—	3.4	30	50	2.0	—	1.35
CSD97370Q5M <sup>1</sup>	N	Yes	30	—	2.8	25	40	2.0	—	1.35

<sup>1</sup>3.3-V and 5-V PWM signal compatible.

\*Suggested resale price in U.S. dollars in quantities of 1,000.

# Linear Regulators

## New Wide- $V_{IN}$ Linear Regulators Remove Switching Noise

### TPS7A3001, TPS7A4901

The waveforms show two examples of connecting an LDO to the output of a switching DC/DC converter with magnetics, which improves the ripple voltage by removing inherent switching noise. The voltage can now be used in noise-sensitive applications to greatly increase the performance of analog sensing circuitry.

The wide-input-voltage TPS54060 DC/DC converter shown in the block diagram is configured in an inverting buck/boost topology with an off-the-shelf coupled inductor to generate a positive and negative output voltage. Linear regulators TPS7A4901 and TPS7A3001 provide clean positive and negative power to highly noise-sensitive analog circuitry.

### Key Features

- Wide input voltages:  $\pm 3.0$  to  $\pm 36$  V
- 1.5% nominal accuracy
- Stable with  $>2.2\text{-}\mu\text{F}$  ceramic output capacitor
- Low noise/high PSRR:
  - Output noise as low as  $16\text{ }\mu\text{V}_{\text{RMS}}$
  - PSRR of 72 dB at 1 kHz and 55 dB at 10 to 700 kHz

### Key Benefits

- Better precision for VCOs, PLLs and ADCs
- Smaller size and lower cost than tantalums
- Improved dynamic range in RF applications, filters and handling DC/DC spikes

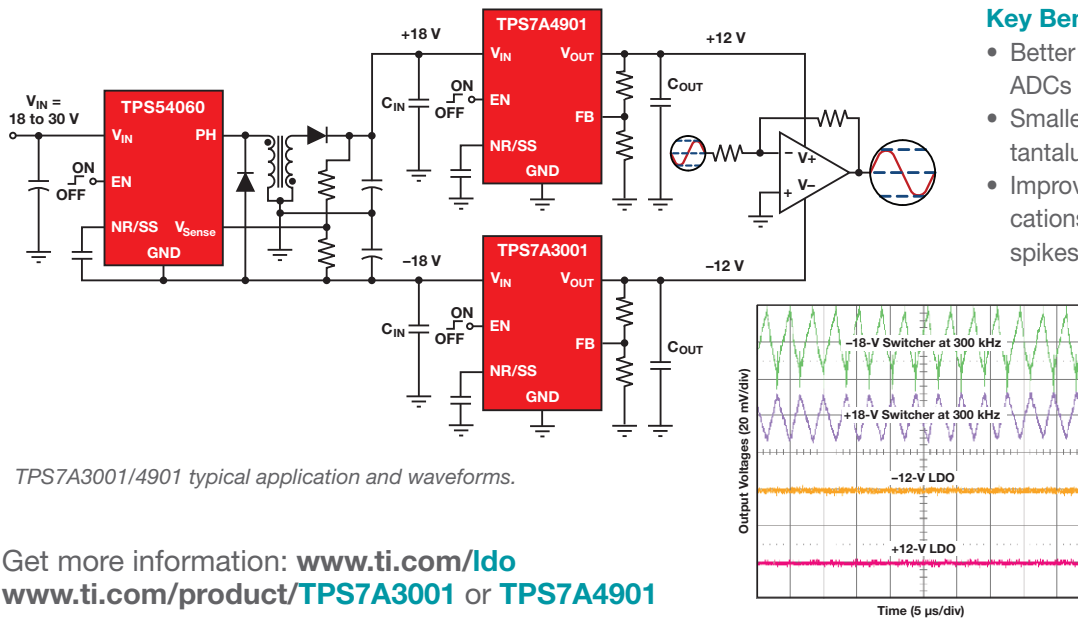

TPS7A3001/4901 typical application and waveforms.

The reference design is available at:  
[www.ti.com/tool/pmp5863.1](http://www.ti.com/tool/pmp5863.1)

Get more information: [www.ti.com/lldo](http://www.ti.com/lldo)  
[www.ti.com/product/TPS7A3001](http://www.ti.com/product/TPS7A3001) or [TPS7A4901](http://www.ti.com/product/TPS7A4901)

## Industry's Cleanest, Ultra-Low-Noise LDO

NEW

### TPS7A4700

The TPS7A4700 is a positive-voltage ( $+36$  V), ultra-low-noise ( $4.17\text{ }\mu\text{V}_{\text{RMS}}$ ) linear regulator capable of sourcing a 1-A load. In addition, the LDO output voltage is fully user adjustable via a PCB layout without the need of external resistors or feed-forward capacitors, reducing overall component count.

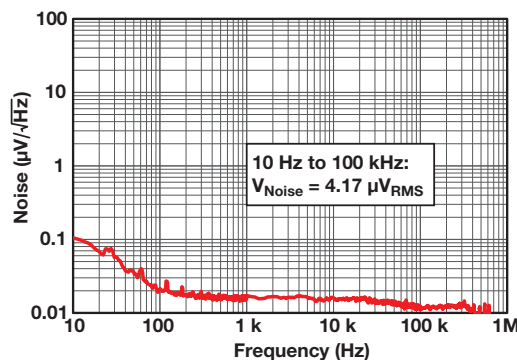

TPS7A4700 spectral noise plot

### Key Features

- Extremely low noise/high PSRR
- Robust for high-line voltage transients
- Higher precision for VCO/PLL/ADC
- Improved size/cost
- No external resistors required to set  $V_{\text{out}}$

Get more information: [www.ti.com/product/TPS7A4700](http://www.ti.com/product/TPS7A4700)



# Linear Regulators

## Ultra-Low Noise, 150-mA Linear Regulator for RF/Analog Circuits

### LP5900

The LP5900 is a linear regulator capable of supplying 150-mA output current. Designed to meet the requirements of RF/analog circuits, the LP5900 device provides low noise, high PSRR, low quiescent current, and low line transient response figures. Using new innovative design techniques the LP5900 offers class-leading device noise performance without a noise bypass capacitor.

The device is designed to work with 0.47- $\mu\text{F}$  input and output ceramic capacitors. (No bypass capacitor is required) The device is available in micro SMD package and LLP package. Also available in Exteme Thin micro SMD package.

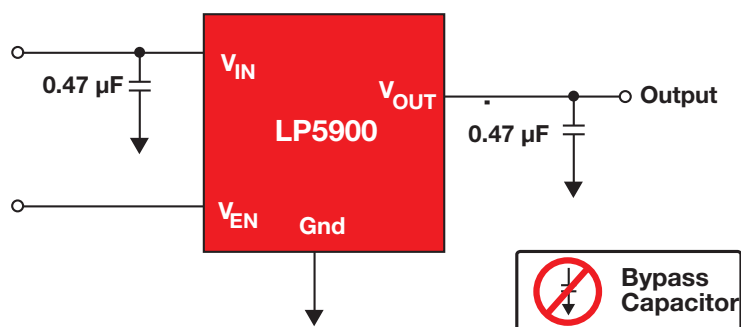

Get more information: [www.ti.com/product/LP5900](http://www.ti.com/product/LP5900)

### Key Features

- Stable with 0.47- $\mu\text{F}$  ceramic input and output capacitors
- No noise bypass capacitor required
- Logic controlled enable
- Thermal-overload and short-circuit protection
- $-40^{\circ}\text{C}$  to  $+125^{\circ}\text{C}$  junction temperature range for operation

### Applications

- Cellular phones
- PDA handsets
- Wireless LAN devices

## High-Voltage, Low- $I_Q$ Linear Voltage Regulator for Battery Packs

### TPS7A16xx

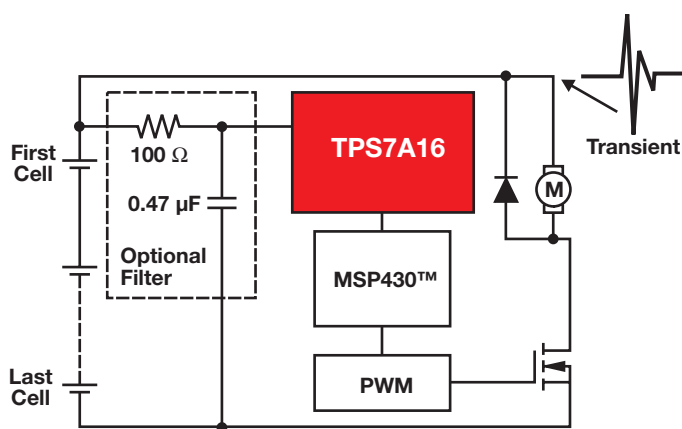

Get more information: [www.ti.com/product/TPS7A1601](http://www.ti.com/product/TPS7A1601)

### Key Features

- $V_{\text{IN}}$ : 3 to 60 V
- $I_{\text{OUT}}$ : 100 mA
- $V_{\text{DO}}$ : 60 mV at 20 mA
- $I_Q$  of 5  $\mu\text{A}$
- High- $V_{\text{IN}}$  LDO with EN and PG
- MSOP-8 PowerPAD™ package

### Applications

- E-metering
- Remote controllers
- Portable electronics powered from 9- to 12-V battery
- Smoke detectors/security
- Automotive
- High-cell-count battery packs for power tools

# Linear Regulators

## Low Dropout (LDO) Regulators Selection Guide

Device	I <sub>Q</sub> (no load) (A)	V <sub>IN</sub> Range (V)	I <sub>OUT</sub> (mA)	Price*
<b>Low I<sub>Q</sub></b>				
TPS780/2xx	0.42	2.2 to 5.5	150	0.25
TPS709xx	1	2.5 to 30	150	0.39
TPS797xx	1.2	2.7 to 5.5	50	0.34
TPS715A	3.2	2.5 to 24	80	0.40
TPS7A16xx	5	3 to 60	100	1.40
TPS727xx	7.9	2 to 5.5	400	0.48

Device	Drop Out (V)	V <sub>IN</sub> Range (V)	I <sub>OUT</sub> (A)	Price*
<b>Low Dropout Voltage (With Bias Control Input)</b>				
TPS74701	50	0.8 to 5.5	0.5	0.75
TPS742/3/8	55	0.8 to 5.5	1.5	1.00
TPS744/9	115	0.8 to 5.5	3	2.00
LP38851	115	0.95 to 5.5	0.8	0.71
TPS720xx	130	1.1 to 4.5	0.32	0.37
LP38852/5/8	130	1.15 to 5.5	1.5	0.85
LP38853/6/9	240	1.15 to 5.5	3	1.60

Device	V <sub>IN</sub> Range (V)	I <sub>OUT</sub> (mA)	Price*
<b>Wide V<sub>IN</sub></b>			
TPS7A40xx	7 to 100	50	1.05
LM9076	5.35 to 70	150	0.82
TPS7A16xx	3 to 60	100	1.40
LM2936HV	4 to 60	50	0.70
TPS709	3 to 30	150	0.39
TPS715A	2.5 to 24	80	0.40
LMS1585A	5 to 13	5000	1.00
LM1084	5 to 27	5000	1.00

\*Suggested resale price in U.S. dollars in quantities of 1,000.

## Dual Output LDOs Selection Guide

Device	I <sub>O1</sub> (mA)	I <sub>O2</sub> (mA)	V <sub>DO1</sub> at I <sub>O1</sub> (mV)	V <sub>DO2</sub> at I <sub>O2</sub> (mV)	I <sub>Q</sub> (µA)	Output Options		Accuracy (%)	Package(s)	V <sub>O</sub>		Enable	V <sub>IN</sub>		Comments	Price*
						Fixed Voltage (V)				(min) (V)	(max) (V)		(min) (V)	(max) (V)		
LP2967	200	200	240	240	200	1.8/2.5, 1.8/3.3, 2.5/2.8, 2.5/3.3, 2.6/2.6, 2.8/2.8		1.25	Mini-SO8, micro SMD	1.8	3.3	EN		16		0.99
LP2966	150	150	135	135	300	1.8/3.3, 2.5/1.8, 2.5/2.5, 2.8/2.8, 3.3/2.5, 5.0/5.0		1	Mini-SO8	1.8	5	EN		7		0.70
LP3996	150	300	110	210	35	0.8 to 3.3			LLP10			EN	2	6	Power-on reset	0.30
LP5996	150	300	110	210	35	0.8 to 3.3			LLP10			EN	2	6		0.30
LP8900	200	200	110	110	35	1.2 to 3.6		1	WCSP			EN	1.8	5.5		0.30
TLV710	200	200	175	175	70	1.8/2.8		2	SON 6	1.2	4.8	EN	2.0	5.5	Value-priced dual LDO	0.32
TLV711	200	200	175	175	70	3.3/3.3		2	SON 6	1.2	4.8	EN	2.0	5.5	TLV710xx w/ active output pulldown	0.32
TPS719xx	200	200	230	230	100	1.3/2.8, 1.8/1.2, 1.8/1.3, 2.1/2.2, 2.6/1.5, 2.8/2.8, 2.85/2.85, 3.3/2.8, 3.3/3.3, 3.6/3.15 See Note 1		3	QFN/WCSP	0.9	3.6	EN	2.5	6.5	TPS718xx w/ active output pulldown	0.55
TPS718xx	200	200	230	230	100	1.2/3.3, 1.8/2.7, 1.8/3.3, 2.5/1.2, 2.8/2.8, 2.8/3.0 See Note 1		3	QFN/WCSP	0.9	3.6	EN	2.5	6.5	High PSRR, low V <sub>OUT</sub>	0.55
TPS712xx	250	250	145	145	400	1.8/2.85, 1.8/Adj., 2.8/2.8, 2.8/Adj., 2.85/2.85		2	QFN	1.2	5.5	EN	2.7	5.5		0.80

<sup>1</sup>EEPROM programmable at the factory, allowing production of custom fixed voltages. Minimum quantities apply. Please contact TI.

\*Suggested resale price in U.S. dollars in quantities of 1,000.

Device	Noise (µV)	PSRR at 1 kHz (dB)	V <sub>IN</sub> Range (V)	I <sub>OUT</sub> (A)	Price*
<b>Ultra-Low Noise/High PSRR</b>					
TPS7A4700	4.17	82	3 to 36	1	2.10
LP5900/4/7	6.5	75	2.2 to 5.5	0.15/0.2/0.25	0.20
TPS742/3/4	12	73	0.8 to 5.5	1.5/3	2.00
TPS7A4901	15	72	3 to 36	0.15	1.10
TPS7A3001	15	72	-3 to -36	0.2	1.50
TPS7A3301	16	72 at 10 kHz	-3 to -36	0.15	2.70
LP2989/LV	18	60	2.1 to 16	0.5	0.70
TPS3878-ADJ	18	60	2.5 to 16	0.8	0.80
TPS7A8101	23.5	80	2.2 to 6.5	1	1.00
TPS71701	33.5	70	2.5 to 6.5	0.15	0.36

Device	Drop Out (V)	V <sub>IN</sub> Range (V)	I <sub>OUT</sub> (A)	Price*
<b>Low Dropout Voltage (Without Bias Control Input)</b>				
TPS731/2/6	30/40/75	1.7 to 5.5	0.15/0.25/0.40	0.33
TPS799xx	100	2.7 to 6.5	0.2	0.30
TPS7A71/2/3	200	1.5 to 7.0	1/2/3	1.05
LP3881/2/3	75/110/210	1.5 to 5.5	0.8/1.5/3	1.95
TPS735/7	280/130	2.2 to 5.5	0.5/1	0.60
LP38511/2/3	135/250/425	2.25 to 5.5	0.8/1.5/3	0.75

Device	Load Transient (mV)	V <sub>IN</sub> Range (V)	I <sub>OUT</sub> (A)	Price*
<b>Fast Transient Response</b>				
LP5907	± 20	2.2 to 5.5	0.25	0.23
TPS727	± 50	2 to 5.5	0.25	0.48
TPS742/3/4	± 50	0.8 to 5.5	1.5/3	2.00
LP3851x	± 50	2.25 to 5.5	0.8/1.5/3	0.60
TPS717	± 65	2.5 to 5.5	0.15	0.36

# Battery Management Products

## Overview

TI battery management solutions support a wide range of battery chemistries and cell counts, from popular Lithium-Ion (Li-Ion) technologies to industry-standard nickel-metal-hydride and lead-acid batteries. Because space is of utmost importance in portable applications, TI offers advanced solutions that incorporate QFN and wafer-level chip-scale packaging and feature a high degree of integration to reduce solution size. In addition to reducing board space, many of these solutions provide lower power dissipation and increase overall efficiency.

TI products support applications such as mobile phones, smartphones, tablets, portable consumer devices, portable navigation devices, notebook computers and many industrial and medical applications. TI also offers evaluation modules, application notes, samples and

data sheets needed to get your design to market faster.

### Design Factors

**Battery Chemistry** — Each battery chemistry has different operating characteristics, such as discharge profiles and self-discharge rate. TI gas-gauge ICs are developed to account for these differences and accurately display remaining energy in the battery. Also, each battery chemistry has unique requirements for its charge algorithm, which is critical for maximizing its capacity, cycle life and safety.

**Charge-Control Topology** — A simple linear topology works well in applications with low-power (e.g., one- or two-cell Li-Ion) battery packs that are charged at less than 1 A. A switch-mode topology is well-suited for fast charging from USB ports or for large battery packs that

require charge rates >1 A. The switch-mode conversion minimizes heat generation during charging. A wireless power topology uses shared magnetic fields to provide the benefit of contactless power transfer. Wireless charging provides an additional battery-charging option for portable devices or as a replacement for other 5-V charging sources.

**Input Voltage** — Wide input-voltage range of the IC and input overvoltage protection offer maximum safety and allow use of low-cost unregulated wall adapters.

**Number of Series Cells** — A battery pack is constructed from a string of series and parallel cells. Each series cell, or group of parallel cells, requires protection from overcharge, overdischarge and short-circuit conditions.

## Battery Management

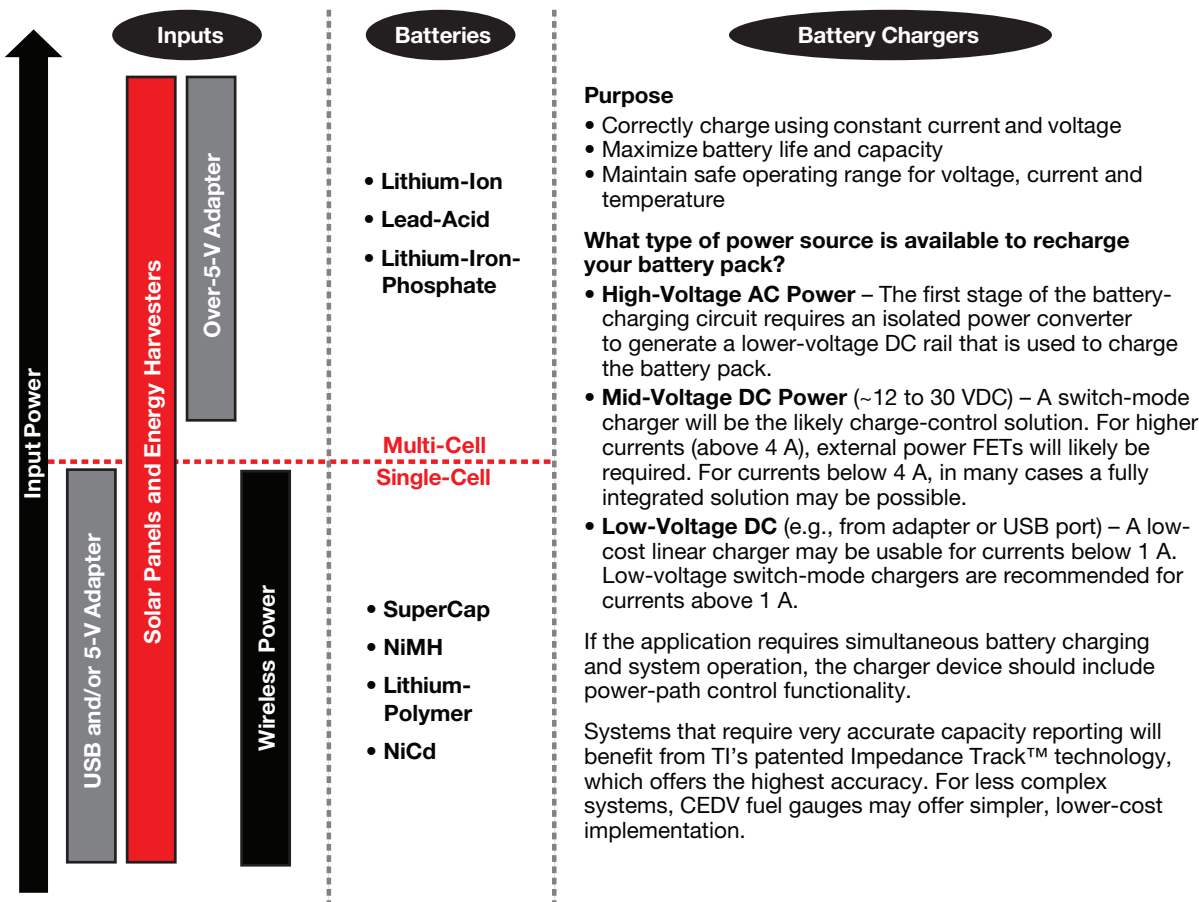

# Battery Management Products

## Battery Charger Solutions

### Industry's Most Efficient Boost Charger for Nanopower Energy-Harvesting Applications

#### bq25504

The bq25504 is a highly efficient boost charger IC for nano (ultra-low) power energy-harvesting and management applications. The device manages microwatts ( $\mu\text{W}$ ) to milliwatts (mW) of power generated from a variety of sources such as solar, thermal electric, electromagnetic and vibration energy.

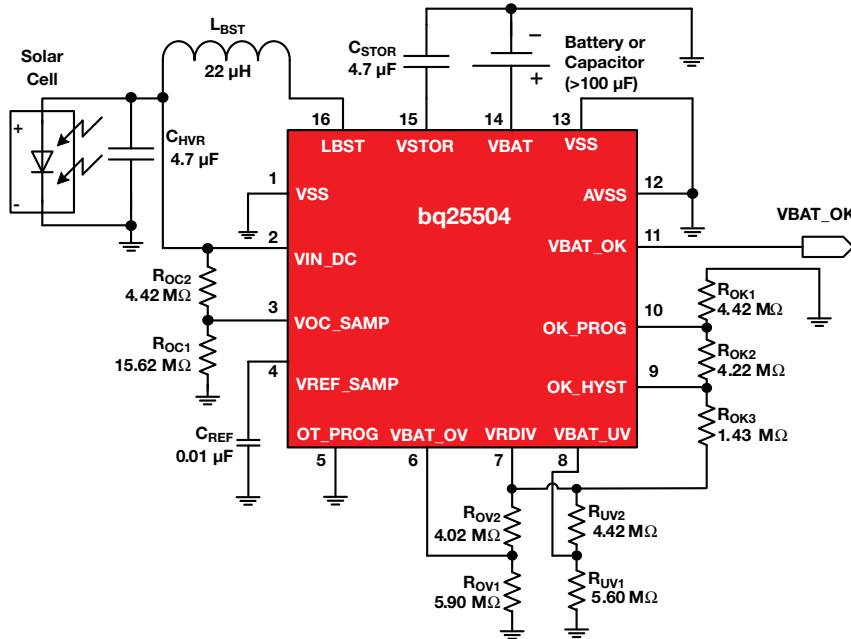

#### Key Features

- Low quiescent current (330 nA typ) and high conversion efficiency
- Maximum power point tracking (MPPT) optimizes energy extracted from DC harvesters such as solar panels and thermoelectric generators
- User-programmable settings support a variety of energy sources and energy storage elements
- Low cold-start voltage (330 mV typ) supports start-up from single-cell solar panels (under low light) and other low-voltage sources.
- Battery status outputs allow conditional enabling of external loads and protects the storage element

#### Applications

- Solar charger
- Thermal electric generator (TEG) harvesting
- Wireless sensor networks
- Industrial and environmental monitoring and smart building controls
- Portable and wearable health devices
- Remote controls

Get more information: [www.ti.com/product/bq25504](http://www.ti.com/product/bq25504)

### 1-A, Single-Input, Single-Cell LiFePO<sub>4</sub> Linear Battery Charger with 50-mA LDO

#### bq25070

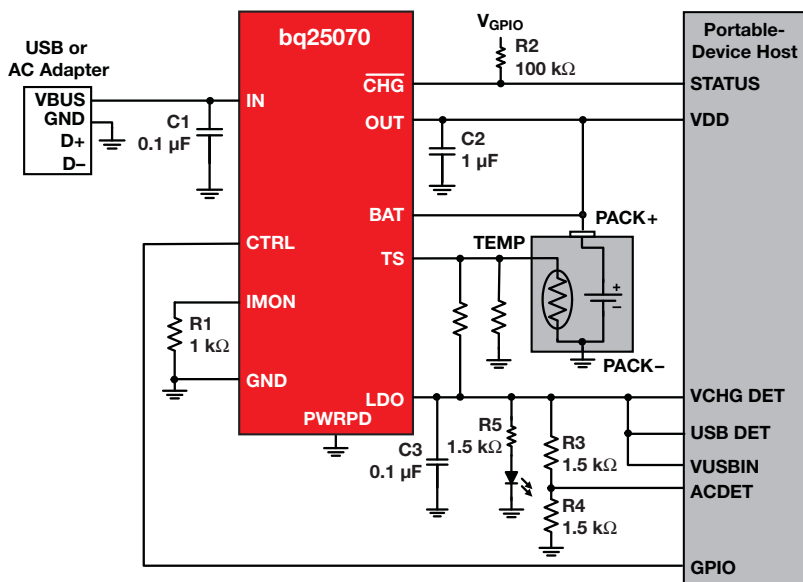

#### Key Features

- Single-cell LiFePO<sub>4</sub> charging algorithm
- 3.75- to 10.2-V  $V_{IN}$  (10.5-V OVP) with 30-V input rating (max)
- Up to 1-A charge current
- Integrated 4.9 V at 50 mA LDO linear regulator
- Single output allows simultaneous battery charging and powering of system
- Programmable charge current through single input interface (CTRL)
- Single USB port or AC-adapter input source
- Thermal regulation and protection
- Soft-start and battery NTC monitoring features

#### Applications

- Low-power handheld devices
- Mobile phones
- Multimedia players

Get more information: [www.ti.com/product/bq25070](http://www.ti.com/product/bq25070)

# Battery Management Products

## Battery Charger Solutions

### 2.5-A, Dual Input, Switch-Mode Charger with Power-Path Management and Host I<sup>2</sup>C Control or Stand Alone

#### bq2416x Family

The bq2416x family of highly integrated, single-cell, Li-Ion battery chargers include system power-path management. They are targeted for space-limited, portable applications with high-capacity batteries.

#### Key Features

- Start-up system from deeply discharged battery or no battery
- Sync 1.5-MHz PWM switch mode
- Supports USB 2.0 and USB 3.0 charger applications
- 20-V max V<sub>IN</sub> rating
- Integrated FETs with 2.5-A charging from V<sub>IN</sub> and 1.5 A on USB input
- Integrated power path and driver for optional external discharge FET
- Integrated input current sensing and limiting (±5%)
- Dual inputs are fully isolated

- Control charge parameters, timers, V<sub>INDPM</sub> threshold
- Thermal regulation protection for output current control
- 2.8x2.8-mm WCSP and 4x4-mm QFN package options

#### Applications

- Handheld portable products
- Portable computing
- Portable media players
- DSC and DVR equipment

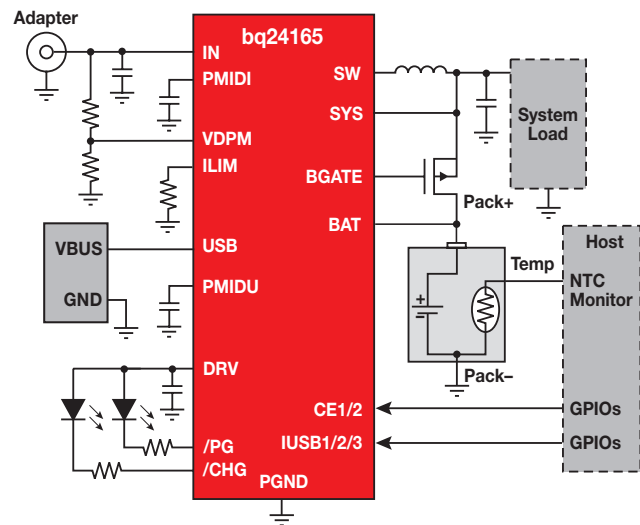
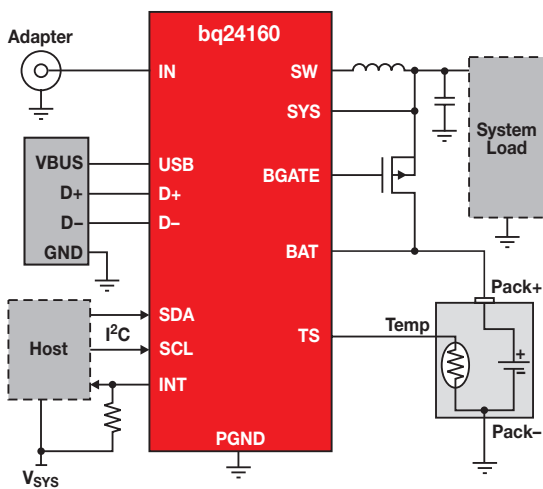

Get more information: [www.ti.com/product/bq24160](http://www.ti.com/product/bq24160) or [bq24165](http://www.ti.com/product/bq24165)

### Single-Cell Charger Controllers Selection Guide

Device	Number of Cells	V <sub>IN</sub> Type	V <sub>IN</sub> Abs Max (V)	V <sub>IN</sub> OVP (V)	Charge Current (A)	Charge Voltage (V)	Topology	Internal FET	Primary Charge Termination	Charge Timer	Temp Monitor	WCSP	QFN	EVM	USB Detection	Price*
<b>Host Mode with I<sup>2</sup>C System Interface</b>																
bq24160	1	Adapter and USB	20	10.5 6.5 USB	2.5 1.5 USB	3.5 to 4.4	Switching	Yes	Host-controlled	Yes	Yes, JEITA	49	24	✓	D+/D-	1.95
bq24161	1	Adapter and USB	20	10.5 6.5 USB	2.5 1.5 USB	3.5 to 4.4	Switching	Yes	Host-controlled	Yes	Yes, Std	49	—	✓	PSEL	1.95
bq24163	1	Adapter and USB	20	10.5 6.5 USB	2.5 1.5 USB	3.5 to 4.4	Switching	Yes	Host-controlled	Yes	Yes, JEITA	49	24	✓	D+/D-	1.95
bq24168	1	Adapter and USB	20	6.5 6.5 USB	2.5 1.5 USB	3.5 to 4.4	Switching	Yes	Host-controlled	Yes	Yes, JEITA	49	24	✓	PSEL	1.95
<b>Stand Alone System Interface</b>																
bq24165	1	Adapter and USB	20	10.5 6.5 USB	2.5 1.5 USB	4.2/4.06	Switching	Yes	10% I <sub>CHG</sub>	Yes	via Host JEITA Adj CE1/2	49	—	✓	I <sub>USB1/2/3</sub>	1.95
bq24166	1	Adapter and USB	20	10.5 6.5 USB	2.5 1.5 USB	4.2/4.06	Switching	Yes	10% I <sub>CHG</sub>	Yes	Yes/Std	24	—	✓	I <sub>USB1/2/3</sub>	1.95
bq24167	1	Adapter and USB	20	10.5 6.5 USB	2.5 1.5 USB	4.2/4.06	Switching	Yes	10% I <sub>CHG</sub>	Yes	via Host JEITA Adj CE1/2	24	24	✓	I <sub>USB1/2/3</sub>	1.95

\*Suggested resale price in U.S. dollars in quantities of 1,000.

# Battery Management Products

## Battery Charger Solutions

### 2.5/4.5-A, I<sup>2</sup>C-Controlled Single-Cell USB/Adapter Charger with Narrow VDC Power-Path Management and USB OTG

**NEW**

#### bq2419x Family

The bq2419x family of fully integrated single-cell 2.5/4.5-A NVDC-1 chargers feature power-path management. This family of devices achieves fast charging, USB detection, and high USB on-the-go (OTG) efficiency with small total solution size.

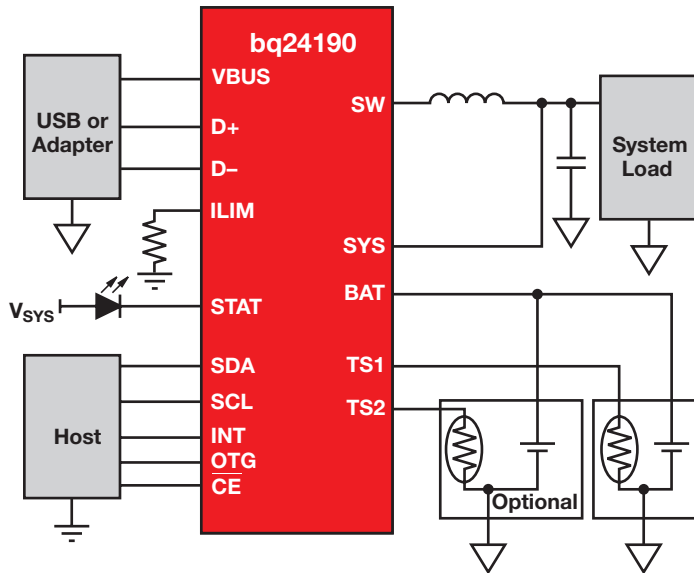

#### Key Features

- NVDC-1 system with power-path management, system instant-on with no battery or deeply discharged battery
- I<sup>2</sup>C host control or autonomous charging with default parameters
- High integration including battery FET, AC switching FETS, current sensing and compensation
- Input-voltage range: 3.9 to 17 V
- USB-compliant 2.5/4.5-A charger with 1.5-MHz switching mode and D+/D- detection or PSEL
- High charging efficiency: 92% at 2.5 A and 90% at 4 A
- High USB OTG efficiency: 90% at 1 A
- Programmable thermal-regulation options 4 x 4-mm QFN package

#### Applications

- Tablets and E-readers
- Fast charging for smartphones
- Applications requiring high instant system power

Get more information: [www.ti.com/product/bq24190](http://www.ti.com/product/bq24190)

### Single-Cell Integrated Charger with I<sup>2</sup>C

Device	Number of Cells	V <sub>IN</sub> Type	V <sub>IN</sub> Max Operating (V)	V <sub>IN</sub> Abs Max (V)	V <sub>IN</sub> OVP (V)	Charge Current (A)	Default Charging Current (A)	Charge Voltage (V)	Default Charging Voltage (V)	Topology	Integrated Power FET	Primary Charge Termination	Charge Timer	Temp Monitor	QFN/MLP	EVM	USB Detection	Price*
<b>Host Control with I<sup>2</sup>C System Interface or Autonomous Charging and USB OTG</b>																		
<b>bq24190</b>	1	Adapter/USB	17	20	18	4.5	2	3.5 to 4.4	4.2	Switching	Yes	Host Controlled	Yes	Yes, Std	24	✓	D+/D-	2.90
<b>bq24192</b>	1	Adapter/USB	17	20	18	4.5	2	3.5 to 4.4	4.2	Switching	Yes	Host Controlled	Yes	Yes, Std	24	✓	PSEL	2.90
<b>bq241921</b>	1	Adapter/USB	17	20	18	4.5	1	3.5 to 4.4	4.1	Switching	Yes	Host Controlled	Yes	Yes, Std	24	✓	PSEL	2.90
<b>bq24193</b>	1	Adapter/USB	17	20	18	4.5	2	3.5 to 4.4	4.2	Switching	Yes	Host Controlled	Yes	Yes, JEITA	24	✓	PSEL	2.90
<b>bq24196</b>	1	Adapter/USB	17	20	18	2.5	2	3.5 to 4.4	4.2	Switching	Yes	Host Controlled	Yes	Yes, Std	24	✓	PSEL	1.95

\*Suggested resale price in U.S. dollars in quantities of 1,000.

New devices are listed in bold red.

# Battery Management Products

## Battery Charger Solutions

### 2.5/4.5-A, I<sup>2</sup>C-Controlled, Single-Cell USB/Adapter Charger with 1.0/2.1-A Synchronous Boost Operation

**NEW**

#### bq24195L, bq24195

The bq24195L is a fully integrated 2.5-A charger with 1-A synchronous boost operation. The bq24195 is a fully integrated 4.5-A charger with 2.1-A synchronous boost operation. They are the one-chip solutions for 1S battery backup with high synchronous boost efficiency.

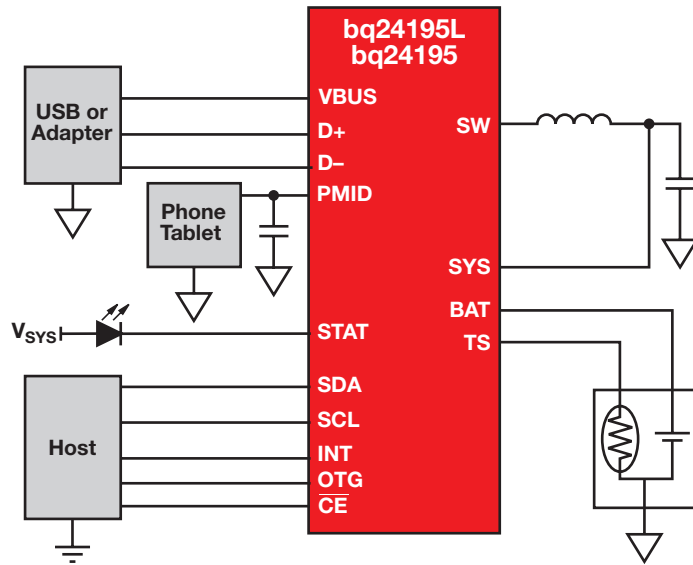

#### Key Features

- Fully integrated single-chip solution for 1S battery
- USB-compliant 1.5-MHz switching-mode charger with D+/D- detection
- High synchronous boost efficiency: 94% at 1 A and 90% at 2.1 A
- High charging efficiency: 92% at 2.5 A and 90% at 4 A
- I<sup>2</sup>C host control or autonomous charging with default parameters
- Input-voltage range: 3.9 to 17 V
- 4 x 4-mm QFN package

#### Applications

- Power bank, power pack, juice pack for smartphone and tablet backup power

Get more information: [www.ti.com/product/bq24195L](http://www.ti.com/product/bq24195L) or [bq24195](http://www.ti.com/product/bq24195)

### Single-Cell Integrated Chargers with I<sup>2</sup>C

Device	Number of Cells	V <sub>IN</sub> Type	V <sub>IN</sub> Max Operating (V)	V <sub>IN</sub> Abs Max (V)	V <sub>IN</sub> OVP (V)	Charge Current (A)	Default Charging Current (A)	Charge Voltage (V)	Default Charging Voltage (V)	Topology	Integrated Power FET	Primary Charge Termination	Charge Timer	Temp Monitor	QFN/MLP	EVM	USB Detection	Price*
<b>Host Control with I<sup>2</sup>C System Interface or Autonomous Charging and Synchronous Boost Operation</b>																		
<b>bq24195L</b>	1	Adapter/USB	17	20	18	2.5	2	3.5 to 4.4	4.2	Switching	Yes	Host Controlled	Yes	Yes	24	✓	D+/D-	2.90
<b>bq24195</b>	1	Adapter/USB	17	20	18	4.5	2	3.5 to 4.4	4.2	Switching	Yes	Host Controlled	Yes	Yes	24	✓	D+/D-	3.25

\*Suggested resale price in U.S. dollars in quantities of 1,000.

New devices are listed in bold red.

# Battery Management Products

## Battery Charger Solutions

### 2.0-A Switch-Mode Charger with Power-Path Management and Host I<sup>2</sup>C or Stand Alone Control Option

#### bq2425x Family

The bq2425x family of chargers is ideal for space-constrained portable applications. The flexible architecture of these chargers allows support of multiple Li-Ion battery types with a single device.

#### Key Features

- 20-V-input tolerant; operation up to 10.5 V (bq24250/1/3) or 6.5 V (bq24256/7)
- NVDC architecture
- Input-voltage dynamic power management allows compatibility with multiple external adapter types

- Charge-time optimizer—fastest possible charge rate at any power level
- Compliant with BC1.2 and JEITA standards

#### bq24250/1/6/7 Features

- I<sup>2</sup>C Interface or stand-alone mode in one device

- Automatic USB current setting from D+/D– (bq24251/6/7) or EN1/EN2 from host (bq24250)
- Programmable battery-charge output between 3.5 and 4.44 V using I<sup>2</sup>C or 4.2 V fixed

#### bq24253 Features

- Fixed battery-charge regulation at 4.2 V
- USB charge rate select using D+/D– detection
- Resistor-programmable current limits

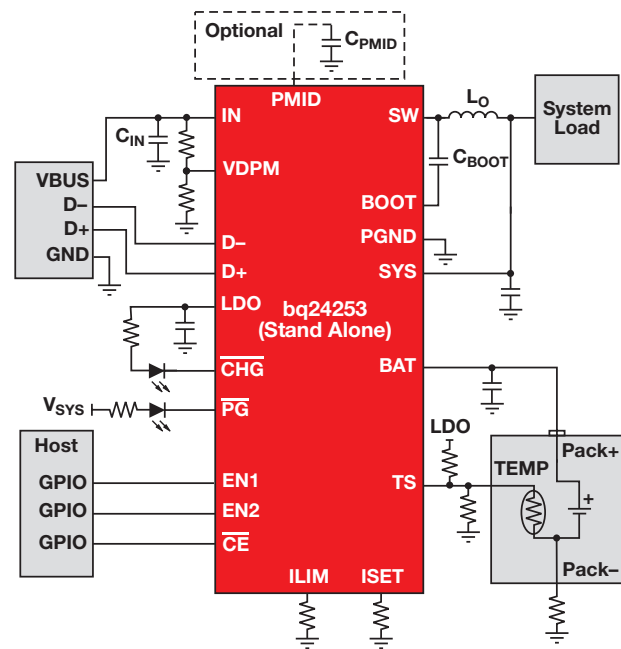
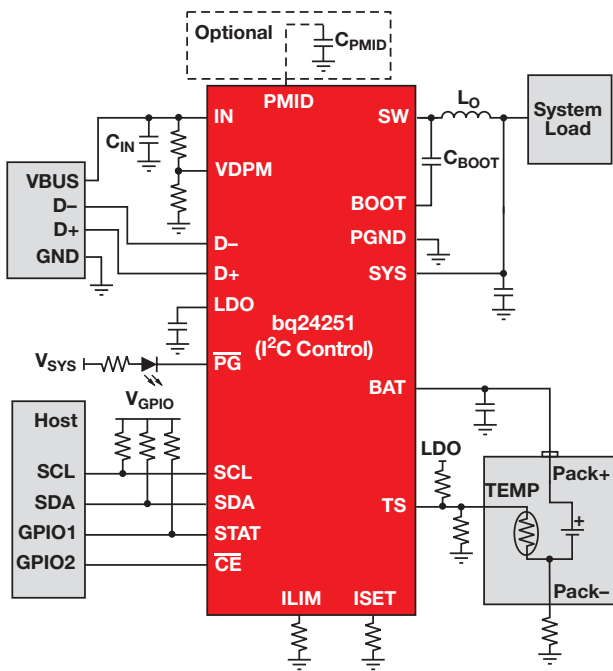

Get more information: [www.ti.com/product/bq24251](http://www.ti.com/product/bq24251) or [bq24253](http://www.ti.com/product/bq24253)

### Selection Guide

(Device parameters continued below)

Device	Number of Cells	V <sub>IN</sub> Type	V <sub>IN</sub> Max Operating (V)	V <sub>IN</sub> Absolute Max (V)	V <sub>IN</sub> OVP (V)	Charge Current (A)	Charge Voltage (V)	Control Interface	Topology	Integrated Power FET
bq24250/51	1	Adapter/USB	18	20	10.5	2.0	3.5 to 4.4	I <sup>2</sup> C and Stand Alone	Switching	Yes
bq24253	1	Adapter/USB	18	20	10.5	2.0	4.2	Stand Alone	Switching	Yes
bq24257	1	Adapter/USB	18	20	6.5	2.0	3.5 to 4.4	I <sup>2</sup> C and Stand Alone	Switching	Yes

(Device parameters continued from above)

Device	Primary Charge Termination	Charge Timer	Temperature Monitor	Packaging			Comments	Price*
				WCSP	QFN/MLP	EVM		
bq24250/51	10% ICHG	Yes	Yes	30	24	✓	EN1-2 or D+/D– detection, JEITA, Power Path	1.15
bq24253	10% ICHG	Yes	Yes	30	24	✓	D+/D– detection, JEITA, Power Path	1.15
bq24257	10% ICHG	Yes	Yes	30	24	✓	D+/D– detection, JEITA	1.15

\*Suggested resale price in U.S. dollars in quantities of 1,000.



# Battery Management Products

## Battery Charger Solutions

### 3.0-A-Output, 30-V-Input Switch-Mode Charger with Power-Path Management and USB OTG Support; Host I<sup>2</sup>C Control or Stand Alone



#### bq2426x Family

The bq2426x family of chargers offers higher current levels and wide-input-voltage tolerance. These chargers are ideal for compact, higher-power applications using single-cell Li-Ion batteries.

#### Key Features

- 30-V-input tolerant; operation up to 6.5 V (bq24262), 10.5 V (bq24260) or 14 V (bq24261/5) allows compatibility with 5-V or 12-V adapter types
- NVDC architecture
- USB OTG support (5-V output at 1 A)
- Charge-time optimizer—fastest possible charge rate at any power level

- Compliant with BC1.2 and JEITA standards

#### bq24260/1/2 Features

- I<sup>2</sup>C Control
- Automatic USB current setting from D+/D- (bq24260) or PSEL from USB PHY (bq24261/2)

- Programmable battery-charge output between 3.5 and 4.4 V
- Programmable charge-termination current

#### bq24265 Features

- Stand-alone operation
- Fixed battery-charge regulation at 4.2 V
- Resistor-programmable and GPIO-controlled current limits
- Fixed charge termination at 10% of fast charge current

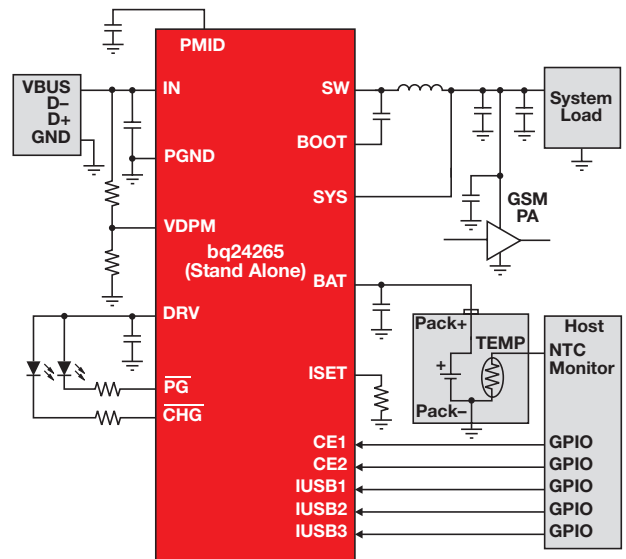
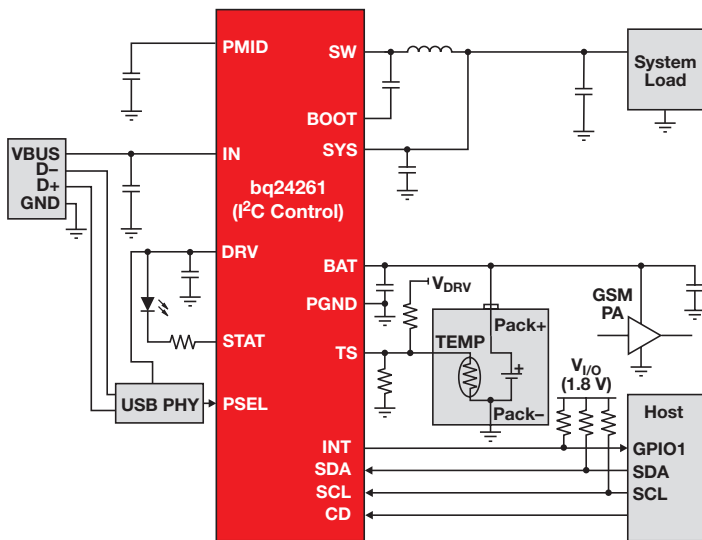

## Selection Guide

(Device parameters continued below)

Device	Number of Cells	V <sub>IN</sub> Type	V <sub>IN</sub> Max Operating (V)	V <sub>IN</sub> Absolute Max (V)	V <sub>IN</sub> OVP (V)	Charge Current (A)	Charge Voltage (V)	Control Interface	Topology	Integrated Power FET
<b>bq24260</b>	1	Adapter/USB	28	30	10.5	3.0	3.5 to 4.4	I <sup>2</sup> C	Switching	Yes
<b>bq24261</b>	1	Adapter/USB	28	30	14	3.0	3.5 to 4.4	I <sup>2</sup> C	Switching	Yes
<b>bq24265</b>	1	Adapter/USB	28	30	14	3.0	4.2	Stand Alone	Switching	Yes

(Device parameters continued from above)

Device	Primary Charge Termination	Charge Timer	Temperature Monitor	Packaging			Comments	Price*
				WCSP	QFN/MLP	EVM		
<b>bq24260</b>	Host Controlled	Yes	Yes	36	24	✓	D+/D- detect, JEITA, Power Path, OTG	1.75
<b>bq24261</b>	Host Controlled	Yes	Yes	36	24	✓	PSEL detect, JEITA, Power Path, OTG	1.75
<b>bq24265</b>	10% ICHG	Yes	Yes	36	24	✓	IUSB pins, JEITA, OTG	1.75

\*Suggested resale price in U.S. dollars in quantities of 1,000.

Preview devices are listed in bold teal.

# Battery Management Products

## Battery Charger Solutions

### Switch-Mode Li-Ion and Li-Polymer Stand-Alone Battery Charger with Integrated FETs

#### bq24170

The bq24170 is a highly integrated stand-alone Li-Ion or Li-Polymer switch-mode battery charger with two integrated n-channel power MOSFETs. It offers a constant-frequency synchronous PWM controller with highly accurate regulation of input current, charge current and voltage. It closely monitors the battery-pack temperature to allow charging only in a preset temperature window. It also provides battery detection, preconditioning, charge termination and charge-status monitoring.

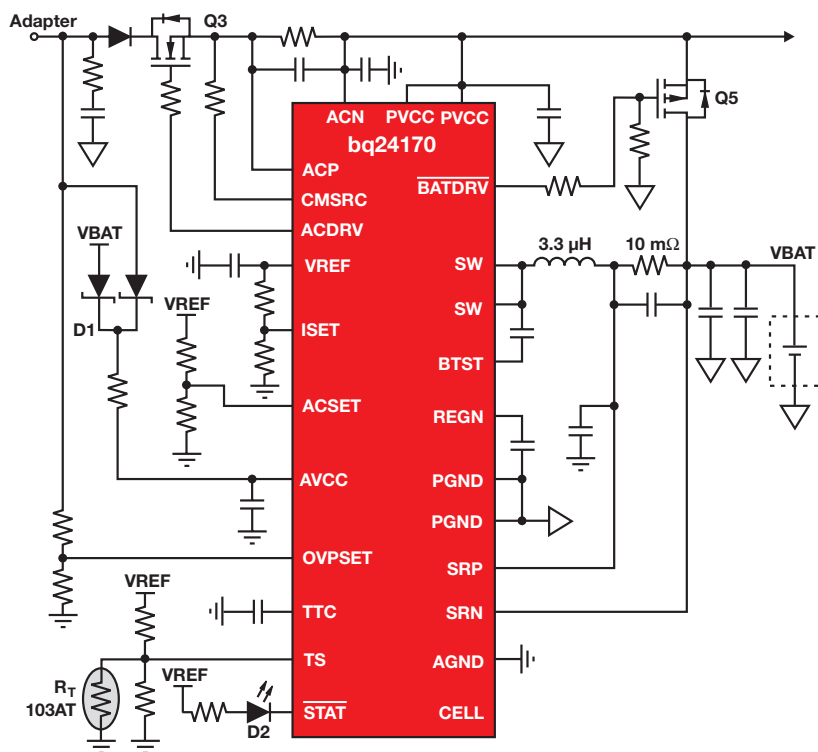

#### Key Features

- 1.6-MHz synchronous switch-mode charger with 4-A integrated n-channel MOSFETs
- Up to 94% efficiency
- 4.5-V to 17-V input operating range
- Battery charge voltage: 1, 2 or 3 cells with 4.2 V per cell

#### Applications

- Tablet PCs
- Netbooks and ultra-mobile computers
- Portable data-capture terminals
- Portable printers
- Medical-diagnostics equipment
- Battery-bay chargers
- Battery back-up systems

Get more information: [www.ti.com/product/bq24170](http://www.ti.com/product/bq24170)

### Chargers with Internal FETs Selection Guide

Device	Number of Cells	Control Topology	Host or Stand Alone	Integrated Power FET	Charge Current (A)	V <sub>IN</sub> Max (V)	Primary Charge Termination Method <sup>1</sup>	Safety Timer	Temp Monitor	Packaging: QFN/MLP	EVM	Comments	Price*
<b>Multi-Cell Switch-Mode Stand-Alone Battery Chargers with Internal FETs (Converters) — Lithium-Ion</b>													
bq24170	1 to 3	Switching	Stand Alone	Yes	4.0	20	Min current	Yes	Yes	24	✓		1.80
bq24171	1 to 3	Switching	Stand Alone	Yes	4.0	20	Min current	Yes	Yes	24	✓	Supports JEITA	1.80
bq24172	1 to 3	Switching	Stand Alone	Yes	4.0	20	Min current	Yes	Yes	24	✓	Supports adjustable charge voltage	1.80
bq24133	1 to 3	Switching	Stand Alone	Yes	2.5	20	Min current	Yes	Yes	24	✓	Supports 2.5-A charge current	1.80
bq24130	1 to 3	Switching	Host	Yes	4.0	20	Min current/Host controlled	—	Yes	24	✓	Charges battery or super capacitor	1.80
bq24100	1	Switching	Stand Alone	Yes	2.0	20	Min current	Yes	Yes	20	✓	On/Off status pin; bq24120 offers enhanced EMI performance	2.00
bq24108	1	Switching	Stand Alone	Yes	2.0	20	Min current	Yes	Yes	20	✓	Blinking status pin; bq24120 offers enhanced EMI performance	2.00
bq24103A	1 or 2	Switching	Stand Alone	Yes	2.0	20	Min current/Host controlled	Yes	Yes	20	✓	bq24123 offers enhanced EMI performance	2.00
bq24113A	1 or 2	Switching	Host	Yes	2.0	20	Min current/Host controlled	Yes	Yes	20	✓	bq24123 offers enhanced EMI performance	2.00
bq24105	1 to 3	Switching	Host	Yes	2.0	20	Min current/Host controlled	Yes	Yes	20	✓	bq24125 offers enhanced EMI performance	3.50
bq24115	1 to 3	Switching	Host	Yes	2.0	20	Min current/Host controlled	Yes	Yes	20	✓	bq24125 offers enhanced EMI performance	3.50

<sup>1</sup>Host controlled = system processor must terminate charging.

\*Suggested resale price in U.S. dollars in quantities of 1,000.

# Battery Management Products

## Battery Charger Solutions

### Stand-Alone Synchronous Switch-Mode Li-Ion or Li-Polymer Battery Charger

#### bq24610

The bq24610 is a highly integrated Li-Ion or Li-Polymer switch-mode battery charger. It offers a constant-frequency synchronous switching PWM controller with highly accurate regulation of charge current and voltage. It also provides charge preconditioning, termination, adapter current regulation and charge-status monitoring.

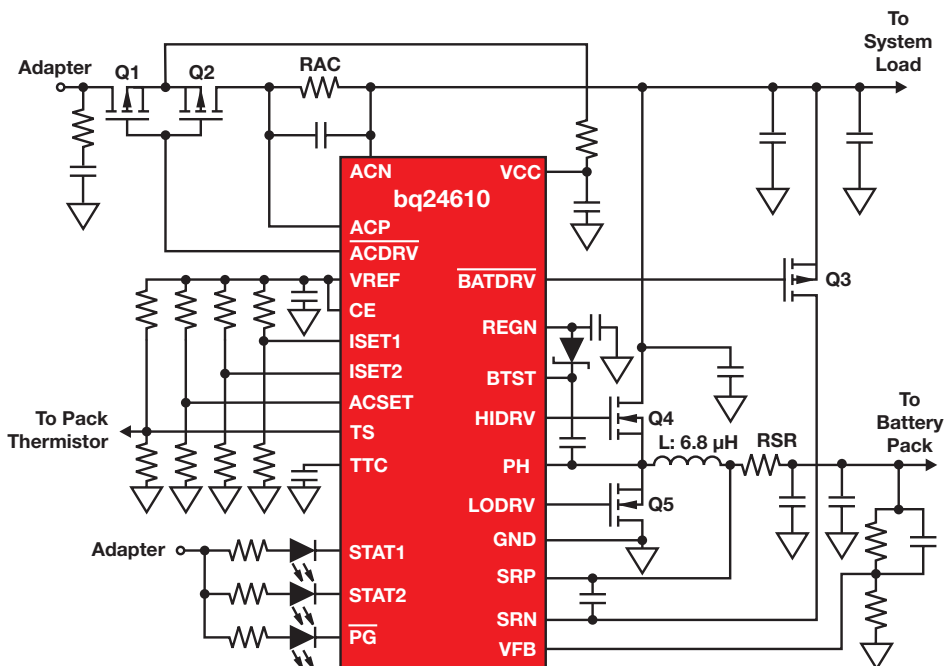

#### Key Features

- 600-kHz NMOS/NMOS synchronous buck converter
- Stand-alone charger support for Li-Ion or Li-Polymer battery
- Supports up to six battery cells (bq24610) and has an input operating range of 5- to 28-V  $V_{CC}$
- Up to 10-A charge current and adapter current

#### Applications

- Netbooks, mobile Internet devices and ultra-mobile PCs
- PDAs
- Handheld terminals
- Industrial and medical equipment

Get more information: [www.ti.com/product/bq24610](http://www.ti.com/product/bq24610)

### Multi-Cell Charger Controllers Selection Guide

Device	Number of Cells	Control Topology	Integrated Power FET	$V_{IN}$ Max (V)	Primary Charge Termination Method	Safety Timer	Temp Monitor	Packaging: QFN/MLP	EVM	Comments	Price*
<b>Multi-Cell Switch-Mode Stand-Alone Battery Chargers with External FETs (Controllers) — Lithium-Ion (except where noted)</b>											
bq24600	1 to 6	Switching	No	32	Min current	Yes	Yes	16	✓	1200 kHz	2.50
bq24610	1 to 6	Switching	No	32	Min current	Yes	Yes	24	✓	600 kHz	2.90
bq24616	1 to 6	Switching	No	32	Min current	Yes	Yes	24	✓	JEITA, 600 kHz	2.90
bq24617	1 to 5	Switching	No	26	Min current	Yes	Yes	24	✓	600 kHz	2.90
bq24618	1 to 6	Switching	No	32	Min current	Yes	Yes	24		Supports 4.7 $V_{IN}$	2.90
bq24620	1 to 7	Switching	No	32	Min current	Yes	No	16	✓	LiFePO <sub>4</sub>	2.90
bq24630	1 to 7	Switching	No	32	Min current	Yes	No	24	✓	LiFePO <sub>4</sub> , system power selector	2.90
bq24640	1 to 9	Switching	No	33	SuperCap-specific	No	Yes	16	✓	Supports SuperCap	3.65
bq24650	1 to 6	Switching	No	33	Min current	Yes	Yes	16	✓	Solar charger for Li-Ion/polymer, LiFePO <sub>4</sub> , lead-acid chemistries	2.85

\*Suggested resale price in U.S. dollars in quantities of 1,000.

# Battery Management Products

## Battery Charger Solutions

### Selection Guide

(Device parameters continued on next page)

Device	Number of Cells	V <sub>IN</sub> Type	V <sub>IN</sub> Max Operating (V)	V <sub>IN</sub> Absolute Max (V)	V <sub>IN</sub> OVP (V)	Charge Current (A)	Charge Voltage (V)	Control Interface	Topology	Integrated Power FET
<b>Multi-Chemistry (Li-Ion and NiCd/NiMH)</b>										
<b>bq24030/31/35</b>	1	Adapter/USB	16	18	6.4	2	4.2/4.1/4.2	Stand Alone	Linear	Yes
<b>bq24032A/38</b>	1	Adapter/USB	16	18	6.4	2	4.2/(4.24/4.36)	Stand Alone	Linear	Yes
<b>bq24040/41</b>	1	Adapter/USB	6.45	30	6.6/7.1	0.800	4.2	Stand Alone	Linear	Yes
<b>bq24050/52</b>	1	Adapter/USB	6.45	30	6.6	0.800	4.2	Stand Alone	Linear	Yes
<b>bq24055</b>	1	Adapter/USB	6.45	30	6.6	0.800	4.2	Stand Alone	Linear	Yes
<b>bq24072/72T</b>	1	Adapter/USB	6.4	30	6.6	1.5	4.3 / 4.2	Stand Alone	Linear	Yes
<b>bq24073</b>	1	Adapter/USB	6.4	28	6.6	1.5	4.2	Stand Alone	Linear	Yes
<b>bq24074</b>	1	Adapter/USB	10.2	28	10.5	1.5	4.2	Stand Alone	Linear	Yes
<b>bq24075T/79T</b>	1	Adapter/USB	6.4	28	6.6	1.5	4.2/4.1	Stand Alone	Linear	Yes
<b>bq24090/91</b>	1	Adapter/USB	6.45	7	6.6	0.800	4.2	Stand Alone	Linear	Yes
<b>bq24092/93</b>	1	Adapter/USB	6.45	7	6.6	0.800	4.2	Stand Alone	Linear	Yes
<b>bq25040</b>	1	Adapter/USB	6.7	30	6.9	1.1	4.2	Stand Alone	Linear	Yes
<b>bq25050</b>	1	Adapter/USB	6	20	6.5	1.25	3.5 to 4.4	I <sup>2</sup> C	Switching	Yes
<b>bq25060</b>	1	Adapter/USB	10.2	30	10.5	1	4.2	Stand Alone	Linear	Yes
<b>bq24140</b>	1	Adapter and USB	9	20	9.8	1.5	Adj	I <sup>2</sup> C	Switching	Yes
<b>bq24153A/58</b>	1	Adapter/USB	6	20	6.5	1.25	3.5 to 4.4	I <sup>2</sup> C	Switching	Yes
<b>bq24156A/59</b>	1	Adapter/USB	9	20	9.8	1.5	3.5 to 4.4	I <sup>2</sup> C	Switching	Yes
<b>bq24160</b>	1	Adapter and USB	18	20	10.5/6.5(USB)	2.5/1.5	3.5 to 4.4	I <sup>2</sup> C	Switching	Yes
<b>bq24161</b>	1	Adapter and USB	18	20	10.5/6.5(USB)	2.5/1.5	3.5 to 4.4	I <sup>2</sup> C	Switching	Yes
<b>bq24163</b>	1	Adapter and USB	18	20	10.5/6.5(USB)	2.5/1.5	3.5 to 4.4	I <sup>2</sup> C	Switching	Yes
<b>bq24165</b>	1	Adapter and USB	18	20	10.5/6.5(USB)	2.5/1.5	4.2	Stand Alone	Switching	Yes
<b>bq24166</b>	1	Adapter and USB	18	20	10.5/6.5(USB)	2.5/1.5	4.2	Stand Alone	Switching	Yes
<b>bq24167</b>	1	Adapter and USB	18	20	10.5/6.5(USB)	2.5/1.5	4.2	Stand Alone	Switching	Yes
<b>bq24168</b>	1	Adapter and USB	18	20	6.5/6.5(USB)	2.5/1.5	3.5 to 4.4	Stand Alone	Switching	Yes
<b>bq24270/71</b>	1	Adapter/USB	18	20	6.5	1.5	3.5 to 4.4	I <sup>2</sup> C	Switching	Yes
<b>bq24272</b>	1	Adapter	18	20	10.5	2.5	3.5 to 4.4	I <sup>2</sup> C	Switching	Yes
<b>bq24273</b>	1	Adapter	18	20	10.5	2.5	3.5 to 4.4	I <sup>2</sup> C	Switching	Yes
<b>bq24278</b>	1	Adapter	18	20	10.5	2.5	4.2	Stand Alone	Switching	Yes
<b>bq24250/51</b>	1	Adapter/USB	18	20	10.5	2.0	3.5 to 4.4	I <sup>2</sup> C and Stand Alone	Switching	Yes
<b>bq24253</b>	1	Adapter/USB	18	20	10.5	2.0	4.2	Stand Alone	Switching	Yes
<b>bq24257</b>	1	Adapter/USB	18	20	6.5	2.0	3.5 to 4.4	I <sup>2</sup> C and Stand Alone	Switching	Yes
<b>bq24259</b>	1	Adapter/USB	18	20	6.5	2.0	4.34	Stand Alone	Switching	Yes
<b>bq24260</b>	1	Adapter/USB	28	30	10.5	3.0	3.5 to 4.4	I <sup>2</sup> C	Switching	Yes
<b>bq24261</b>	1	Adapter/USB	28	30	14	3.0	3.5 to 4.4	I <sup>2</sup> C	Switching	Yes
<b>bq24265</b>	1	Adapter/USB	28	30	14	3.0	4.2	Stand Alone	Switching	Yes
<b>bq24180</b>	1	Adapter/USB	16	20	16.5	1.5	3.5 to 4.4	I <sup>2</sup> C	Switching	Yes
<b>bq24185</b>	1	Adapter/USB	16	20	16.5	1.5	3.5 to 4.4	I <sup>2</sup> C	Switching	Yes
<b>bq24190</b>	1	Adapter/USB	17	20	18	4.5	3.5 to 4.4	I <sup>2</sup> C/Stand Alone	Switching	Yes
<b>bq24192</b>	1	Adapter/USB	17	20	18	4.5	3.5 to 4.4	I <sup>2</sup> C/Stand Alone	Switching	Yes
<b>bq24192I</b>	1	Adapter/USB	17	20	18	4.5	3.5 to 4.4	I <sup>2</sup> C/Stand Alone	Switching	Yes
<b>bq24193</b>	1	Adapter/USB	17	20	18	4.5	3.5 to 4.4	I <sup>2</sup> C/Stand Alone	Switching	Yes
<b>bq24196</b>	1	Adapter/USB	17	20	18	2.5	3.5 to 4.4	I <sup>2</sup> C/Stand Alone	Switching	Yes
<b>bq24195L</b>	1	Adapter/USB	17	20	18	2.5	3.5 to 4.4	I <sup>2</sup> C/Stand Alone	Switching	Yes
<b>bq24195</b>	1	Adapter/USB	17	20	18	4.5	3.5 to 4.4	I <sup>2</sup> C/Stand Alone	Switching	Yes
<b>bq24130</b>	1 to 3	Adapter/USB	18	20	Adj	4	Adj	I <sup>2</sup> C	Switching	Yes
<b>bq24133</b>	1 to 3	Adapter/USB	17	20	Adj	2.5	4.2/Cell	Stand Alone	Switching	Yes
<b>bq24170</b>	1 to 3	Adapter/USB	17	20	Adj	4	4.2/Cell	Stand Alone	Switching	Yes
<b>bq24171</b>	1 to 3	Adapter/USB	17	20	Adj	4	Adj	Stand Alone	Switching	Yes
<b>bq24172</b>	1 to 3	Adapter/USB	17	20	Adj	4	Adj	Stand Alone	Switching	Yes
<b>bq24600</b>	1 to 6	Adapter	28	33	32	10 (Ext)	Adj	Stand Alone	Switching	No
<b>bq24610</b>	1 to 6	Adapter	28	33	32	10 (Ext)	Adj	Stand Alone	Switching	No
<b>bq24616</b>	1 to 6	Adapter	28	33	32	10 (Ext)	Adj	Stand Alone	Switching	No
<b>bq24617</b>	1 to 5	Adapter	24	33	32	10 (Ext)	Adj	Stand Alone	Switching	No
<b>bq24618</b>	1 to 6	Adapter/USB	28	33	32	10 (Ext)	Adj	Stand Alone	Switching	No
<b>bq24707A</b>	1 to 4	Adapter	24	30	Adj	8	Adj	SMBus	Switching	No
<b>bq24725A</b>	2 to 4	Adapter	24	30	Adj	8	Adj	SMBus	Switching	No
<b>bq24735</b>	1 to 4	Adapter	24	30	Adj	8	Adj	SMBus	Switching	No

New devices are listed in bold red. Preview devices are listed in bold teal.

# Battery Management Products

## Battery Charger Solutions

(Device parameters continued from previous page)

Device	Primary Charge Termination	Charge Timer	Temperature Monitor	Packaging						EVM	Comments	Price*	
				WCSP	QFN/MLP	MSOP	TSSOP	SOIC	DIP				
<b>Multi-Chemistry (Li-Ion and NiCd/NiMH)</b>													
<b>bq24030/31/35</b>	Min Current	Yes	Yes		20						✓	Regulated 4.4-V output for AC input condition™	1.80
<b>bq24032A/38</b>	Min Current	Yes	Yes		20						✓	Regulated 4.4-V output for AC input condition	1.80
<b>bq24040/41</b>	Adj/(C/10)	Yes	Yes		10						✓		0.45
<b>bq24050/52</b>	Min Current	Yes	Yes		10						✓	JEITA Charging (100K NTC — bq24052)	0.50
<b>bq24055</b>	Min Current	Yes	Yes		12						✓	JEITA, PG Pin	0.60
<b>bq24072/72T</b>	Min Current	Yes	Yes		16						✓	V <sub>OUT</sub> tracks V <sub>BAT</sub> , V <sub>IN_DPPM</sub>	1.00
<b>bq24073</b>	Min Current	Yes	Yes		16						✓	V <sub>IN_DPPM</sub>	1.00
<b>bq24074</b>	Adj	Yes	Yes		16						✓	V <sub>IN_DPPM</sub>	1.00
<b>bq24075T/79T</b>	Min Current	Yes	Yes		16						✓	SYSOFF pin disconnects battery, V <sub>IN_DPPM</sub> , powers system and charges battery	1.00
<b>bq24090/91</b>	Min Current	Yes	Yes		10						✓	10K NTC (100K NTC — bq24091)	0.40
<b>bq24092/93</b>	Min Current	Yes	Yes		10						✓	JEITA, 10K NTC (JEITA, 100K NTC — bq24093)	0.40
<b>bq25040</b>	Min Current	No	Yes		10						✓	USB compliant w/50-mA integrated LDO	0.55
<b>bq25050</b>	Adj	Yes	No		20						✓	USB OTG supported with boost	0.60
<b>bq25060</b>	Min Current	No	Yes		10						✓	USB compliant w/50-mA integrated LDO	0.65
<b>bq24140</b>	Min Current	Yes	No		30						✓	Simultaneous charge and USB OTG output	1.60
<b>bq24153A/58</b>	Host Controlled	Yes	No		20						✓	USB OTG supported with boost, no battery detect on power up (bq24158)	0.95
<b>bq24156A/59</b>	Host Controlled	Yes	No		20						✓	No battery detect on power up (bq24159)	0.95
<b>bq24160</b>	Host Controlled	Yes	Yes		49	24					✓	D+/D- detect, JEITA, 3-V V <sub>BAT_SHORT</sub>	1.95
<b>bq24161</b>	Host Controlled	Yes	Yes		49						✓	USB selection pin, std temp	1.95
<b>bq24163</b>	Host Controlled	No	No		49	24					✓	D+/D- detect, JEITA	1.95
<b>bq24165</b>	10% I <sub>CHG</sub>	Yes	No		49						✓	I <sub>USB1/2/3</sub> USB select, no temp monitor, JEITA	1.95
<b>bq24166</b>	10% I <sub>CHG</sub>	Yes	Yes		49						✓	I <sub>USB1/2/3</sub> USB select, temp monitor, std temp	1.95
<b>bq24167</b>	10% I <sub>CHG</sub>	Yes	Yes		49	24					✓	I <sub>USB1/2/3</sub> USB select, temp monitor, JEITA	1.95
<b>bq24168</b>	10% I <sub>CHG</sub>	Yes	Yes		49	24					✓	USB select pins, JEITA, no timers	1.95
<b>bq24270/71</b>	Host Controlled	Yes	Yes		49	24					✓	D+/D- detect or PSEL, JEITA, Power Path	1.25
<b>bq24272</b>	Host Controlled	Yes	Yes		49	24					✓	Power Path	1.25
<b>bq24273</b>	Host Controlled	Yes	Yes		49						✓	non-Power Path	1.25
<b>bq24278</b>	10% ICHG	Yes	Yes		49	24					✓	Input current limit programming input	1.25
<b>bq24250/51</b>	10% ICHG	Yes	Yes		30	24					✓	EN1-2 or D+/D- detection, JEITA, Power Path	1.15
<b>bq24253</b>	10% ICHG	Yes	Yes		30	24					✓	D+/D- detection, JEITA, Power Path	1.15
<b>bq24257</b>	10% ICHG	Yes	Yes		30	24					✓	D+/D- detection, JEITA	1.15
<b>bq24259</b>	10% ICHG	Yes	Yes		30	24					✓	EN1-2 detection, JEITA	1.15
<b>bq24260</b>	Host Controlled	Yes	Yes		36	24					✓	D+/D- detect, JEITA, Power Path, OTG	1.75
<b>bq24261</b>	Host Controlled	Yes	Yes		36	24					✓	PSEL detect, JEITA, Power Path, OTG	1.75
<b>bq24265</b>	10% ICHG	Yes	Yes		36	24					✓	I <sub>USB</sub> pins, JEITA, OTG	1.75
<b>bq24180</b>	Host Controlled	Yes	Yes		25						✓	Accessory power output	1.00
<b>bq24185</b>	Host Controlled	Yes	Yes		25						✓	USB OTG supported with boost	1.00
<b>bq24190</b>	Host Controlled	Yes	Yes		24						✓	D+/D-, 1.3-A OTG, standard temp., 12-m battery FET	2.90
<b>bq24192</b>	Host Controlled	Yes	Yes		24						✓	PSEL, 1.3-A OTG, standard temp., 12-m battery FET	2.90
<b>bq24192I</b>	Host Controlled	Yes	Yes		24						✓	PSEL, 1.3-A OTG, standard temp., 1-A default charging	2.90
<b>bq24193</b>	Host Controlled	Yes	Yes		24						✓	PSEL, 1.3-A OTG, JEITA, 12-m battery FET	2.90
<b>bq24196</b>	Host Controlled	Yes	Yes		24						✓	PSEL, 1.3-A OTG, standard temp., 12-m battery FET	1.95
<b>bq24195L</b>	Host Controlled	Yes	Yes		24						✓	D+/D-, 1.0-A synchronous boost for power bank	2.90
<b>bq24195</b>	Host Controlled	Yes	Yes		24						✓	D+/D-, 2.1-A synchronous boost for power bank	3.25
<b>bq24130</b>	Adj	No	Yes		20						✓	Host control, supports Li-Ion and Super Cap	1.95
<b>bq24133</b>	Min Current	Yes	Yes		24						✓	Power Path	1.75
<b>bq24170</b>	Min Current	Yes	Yes		24						✓	Power Path	1.80
<b>bq24171</b>	Min Current	Yes	Yes		24						✓	JEITA, Power Path	1.80
<b>bq24172</b>	Min Current	Yes	Yes		24						✓	Adjustable charge voltage, Power Path	1.80
<b>bq24600</b>	Min Current	Yes	Yes		16						✓	1200 kHz	2.50
<b>bq24610</b>	Min Current	Yes	Yes		24						✓	600 kHz	2.90
<b>bq24616</b>	Min Current	Yes	Yes		24						✓	JEITA	2.90
<b>bq24617</b>	Min Current	Yes	Yes		24						✓	600 kHz	2.90
<b>bq24618</b>	Adj	Yes	Yes		24						✓	USB V <sub>IN</sub> and adapter	2.90
<b>bq24707A</b>	SMBus	Yes	No		20						✓	Programmable switching frequency	2.90
<b>bq24725A</b>	SMBus	Yes	No		20						✓	Programmable switching frequency, enhanced safety, battery learn	2.90
<b>bq24735</b>	SMBus	Yes	No		20						✓	Intel™ CPU Turbo Mode support	3.00

\*Suggested resale price in U.S. dollars in quantities of 1,000.

New devices are listed in bold red. Preview devices are listed in bold teal.

# Battery Management Products

## Battery Charger Solutions

### Selection Guide

(Device parameters continued on next page)

Device	Number of Cells	V <sub>IN</sub> Type	V <sub>IN</sub> Max Operating (V)	V <sub>IN</sub> Absolute Max (V)	V <sub>IN</sub> OVP (V)	Charge Current (A)	Charge Voltage (V)	Control Interface	Topology	Integrated Power FET
<b>Solar/Energy Harvesting (Li-Ion)</b>										
<b>bq24210</b>	1	Adapter/USB	18	20	7.7	0.800	4.2	Stand Alone	Linear	Yes
<b>bq24650</b>	1 to 6	Solar Panel	28	33	32	10 (Ext)	Adj	Stand Alone	Switching	No
<b>bq25504</b>	1	Solar/TEG/Low DC (0.13 V min)	3	5.5	Adj	0.1	2.5 to 5.25	Stand Alone	Boost	Yes
<b>bq25505</b>	1	Solar/TEG/Low DC (0.13 V min)	3	5.5	Adj	0.1	2.5 to 5.25	Stand Alone	Boost	Yes
<b>bq25570</b>	1	Solar/TEG/Low DC (0.13 V min)	3	5.5	Adj	0.1	2.5 to 5.25	Stand Alone	Boost-Buck	Yes
<b>LiFePO<sub>4</sub></b>										
<b>bq25070</b>	1	Adapter/USB	28	30	10.5	1	3.5	Stand Alone	Linear	Yes
<b>bq24620</b>	1 to 7	Adapter	28	33	32	10 (Ext)	Adj	Stand Alone	Switching	No
<b>bq24630</b>	1 to 7	Adapter	28	33	32	10 (Ext)	Adj	Stand Alone	Switching	No
<b>Super Cap</b>										
<b>bq24640</b>	1 to 9	Adapter	28	33	32	10 (Ext)	Adj	Stand Alone	Switching	No
<b>NiCd/NiMH Chemistry</b>										
<b>bq2002/C/E/F</b>	Multiple	Adapter	6	7	—	>2	6	Stand Alone	Current-limited	No
<b>bq2004/E/H</b>	Multiple	Adapter	5.5	7	—	>2	5.5	Stand Alone	Switching	No
<b>bq2005</b>	Multiple	Adapter	5.5	7	—	>2	5.5	Stand Alone	Switching	No
<b>bq24400/1</b>	Multiple	Adapter	5.5	7	—	>2	5.5	Stand Alone	Switching	No
<b>Lead-Acid Chemistry</b>										
<b>bq24450</b>	Multiple	Adapter	40	40	—	>2	—	Stand Alone	Linear	No
<b>UC3909</b>	Multiple	Adapter	40	40	—	>2	—	Stand Alone	Switching	No
<b>bq2031</b>	Multiple	Adapter	5.5	7	—	>2	—	Stand Alone	Switching	No
<b>Multi-Chemistry (Li-Ion and NiCd/NiMH)</b>										
<b>bq2000/T</b>	Multiple	—	—	7	—	—	—	Stand Alone	Switching	Yes
<b>bq24765</b>	2 to 4	—	—	30	—	—	—	Stand Alone	Switching	Yes
<b>bq24650</b>	1 to 6	Solar Panel	28	33	32	10A (Ext)	Adj	Stand Alone	Switching	No
<b>Wireless Power Receivers</b>										
<b>bq51011</b>	Reg V <sub>OUT</sub>	Coil/USB/Adapter	10	20	15	See Comments	5	Stand Alone	Linear	Yes
<b>bq51013</b>	Reg V <sub>OUT</sub>	Coil/USB/Adapter	10	20	15	1.5	5	Stand Alone	Linear	Yes
<b>bq51013A</b>	Reg V <sub>OUT</sub>	Coil/USB/Adapter	10	20	15	1.5	5	Stand Alone	Linear	Yes
<b>bq51013B</b>	Reg V <sub>OUT</sub>	Coil/USB/Adapter	10	20	15	1.5	5	Stand Alone	Linear	Yes
<b>bq51050B/51B</b>	Reg V <sub>OUT</sub>	Coil/USB/Adapter	10	20	15	1.5	5	Stand Alone	Wireless Battery Charger	Yes

Device	Transmitter Type	V <sub>IN</sub> (V)	Magnet	Key Features	Price*
<b>Wireless Power Transmitters</b>					
<b>bq500410A</b>	A6	12	No	1 to 3 coils, large charging area, WPC 1.1 ready	2.85
<b>bq500211A</b>	A5	5	Yes	Power from low-cost 5-V adapter or USB port	2.85
	A11	5	No		
<b>bq500210</b>	A1	19	Yes	Second-generation solution with digital demodulation to reduce component count	4.50
	A10	19	No		

\*Suggested resale price in U.S. dollars in quantities of 1,000.

New devices are listed in bold red. Preview devices are listed in bold teal.

# Battery Management Products

## Battery Charger Solutions

(Device parameters continued from previous page)

Device	Primary Charge Termination <sup>1</sup>	Charge Timer	Temperature Monitor	Packaging						EVM	Comments	Price*		
				WCSP	QFN/MLP	MSOP	TSSOP	SOIC	DIP					
<b>Solar/Energy Harvesting (Li-Ion)</b>														
<b>bq24210</b>	Min Current	Yes	Yes		10						✓	Solar panel V <sub>IN</sub>	1.10	
<b>bq24650</b>	C/10	Yes	Yes		16						✓	Max power point tracking	2.85	
<b>bq25504</b>	Voltage	—	Yes		16						✓	Energy harvester, ultra-low power and quiescent current, high efficiency, dynamic MPPT	2.10	
<b>bq25505</b>	Voltage	—	Yes		16						✓	Energy harvester, 330-nA ultra-low power and quiescent current, high efficiency, dynamic MPPT, autonomous power-path multiplexing	2.40	
<b>bq25570</b>	Voltage	—	Yes		16						✓	Energy harvester, <900-nA ultra-low power and quiescent current, high efficiency, dynamic MPPT	2.90	
<b>LiFePO<sub>4</sub></b>														
<b>bq25070</b>	Min Current	No	Yes		10						✓	LiFePO <sub>4</sub> , 50-mA LDO	0.75	
<b>bq24620</b>	C/10	Yes	Yes		16						✓	LiFePO <sub>4</sub> , 300 kHz	2.90	
<b>bq24630</b>	Adj	Yes	Yes		24						✓	LiFePO <sub>4</sub> , 300 kHz, power selector	2.90	
<b>Super Cap</b>														
<b>bq24640</b>	Min Current	No	Yes		16						✓	SuperCap	2.90	
<b>NiCd/NiMH Chemistry</b>														
<b>bq2002/C/E/F</b>	$\Delta V$ , PVD, $\Delta T/\Delta t$	Yes	Yes						8	8		Trickle charge	0.85	
<b>bq2004/E/H</b>	$\Delta V$ , PVD, $\Delta T/\Delta t$	Yes	Yes						16	16		Selectable timers and pulse-trickle rates	2.15	
<b>bq2005</b>	$\Delta V$ , $\Delta T/\Delta t$	Yes	Yes						20	20		Sequential fast charge of two battery packs	2.15	
<b>bq24400/1</b>	PVD / $\Delta T/\Delta t$	Yes	Yes						8	8			1.55	
<b>Lead-Acid Chemistry</b>														
<b>bq24450</b>	Max V, min I	No	No						16	16		Temp-compensated internal reference	2.75	
<b>UC3909</b>	Max V, min I	No	Yes						20	20		Differential current sense input	3.05	
<b>bq2031</b>	Max V, $-\Delta 2V$ , min I	Yes	Yes						16	16	✓	Three user-selectable charge algorithms to accommodate cyclic and standby applications	2.80	
<b>Multi-Chemistry (Li-Ion and NiCd/NiMH)</b>														
<b>bq2000/T</b>	PVD, $\Delta T/\Delta t$ , min current	Yes	Yes						8	8	8	✓	Charges NiCd, NiMH, and Li-Ion	1.50
<b>bq24765</b>	SMBus	Yes	No		34						✓	SMBus charger with integrated power FETs	3.95	
<b>bq24650</b>	C/10	Yes	Yes		16						✓	Max power point tracking	2.85	
<b>Wireless Power Receivers</b>														
<b>bq51011</b>	EPT Cmd to Tx	No	Yes		28							Receiver, current limited charge current (400 mA + dynamic I <sub>LIM</sub> )	3.50	
<b>bq51013</b>	EPT Cmd to Tx	No	Yes		28						✓	Receiver, regulated voltage output, compliant to WPC specification 1.0	3.50	
<b>bq51013A</b>	EPT Cmd to Tx	No	Yes		28	20					✓	WPC 1.0 receiver, regulated voltage output, dynamic efficiency control, dynamic communications limit	3.50	
<b>bq51013B</b>	EPT Cmd to Tx	No	Yes		28	20					✓	WPC 1.1 receiver, regulated voltage output, dynamic efficiency control, dynamic communications limit	2.50	
<b>bq51050B/51B</b>	EPT Cmd to Tx	No	Yes		28	20					✓	WPC 1.1 receiver, regulated voltage output, dynamic efficiency control, dynamic communications limit, built-in Li-Ion charging	2.75	

<sup>1</sup>PVD = peak voltage detection;  $\Delta T/\Delta t$  = rate of temperature rise; host controlled = system processor must terminate charging;  
 $-\Delta V$  = negative voltage change; max V = maximum voltage; min I = minimum current;  $-\Delta 2V$  = second difference of cell voltage.  
 \*Suggested resale price in U.S. dollars in quantities of 1,000.

New devices are listed in bold red. Preview devices are listed in bold teal.

For a complete list of Resources, visit: [www.ti.com/battery](http://www.ti.com/battery)

# Battery Management Products

## Battery Charger Protection

### Li+ Charger Front-End Protection IC

#### bq24314

Charger front-end protection ICs provide protection from input overvoltage, input overcurrent and battery overvoltage conditions. The tri-level protection offers maximum safety when charging a handheld device. With integrated FET, the protection IC comes in 2x2-mm and 3x4-mm SON packages.

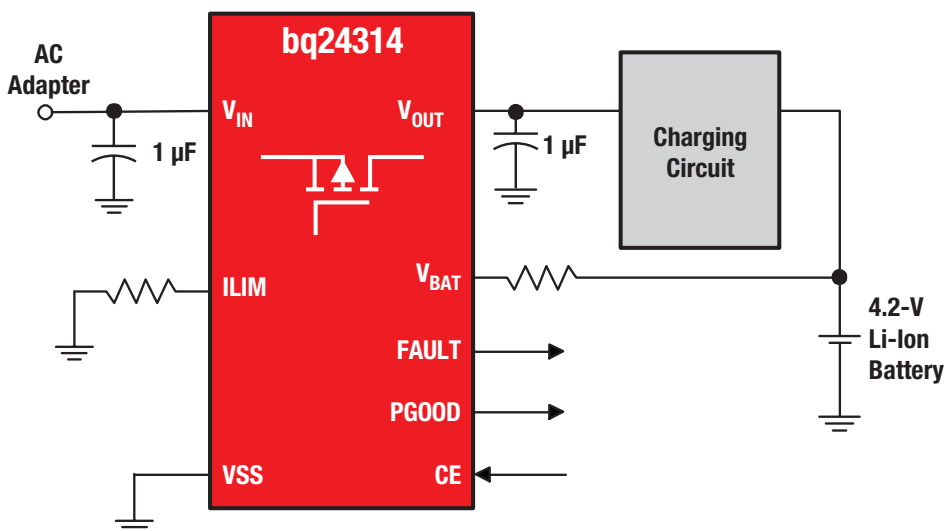

#### Key Features

- 30-V maximum input
- Up to 1.5-A input current
- Thermal shutdown
- Enable input
- Provides protection for three variables:
  - Input overvoltage (rapid response <1 µs)
  - User-programmable overcurrent with current limiting
  - Battery overvoltage

#### Applications

- Mobile phones and smartphones
- Portable navigation devices
- MP3 players
- Low-power handheld devices
- Bluetooth® headsets

Get more information: [www.ti.com/product/bq24314](http://www.ti.com/product/bq24314)

### Selection Guide

Device	V <sub>IN</sub> Max (V)	OVP (V)	OCP	Battery OVP (V)	LDO Output (V)	Max Operating Current (µA)	Package(s)	EVM	Comments	Price*
bq24300/4/5	30	10.5	Fixed 300 mA	4.35	5.5/4.5/5.0	400/500/500	8-QFN/SON	✓	Reverse polarity protection	0.30
bq24308	30	6.3	Fixed 700 mA or Prog. <1.5 A	4.35	5	500	8-QFN/SON	✓	Reverse polarity protection	0.30
bq24312	30	5.85	Prog. <1.5 A	4.35	—	500	8/12-QFN/SON		Fault indication	0.35
bq24313	11	10.5	Prog. <1.5 A	4.35	—	500	8/12-QFN/SON		Fault indication	0.35
bq24314/A	30	5.85	Prog. <1.5 A	4.35	—	600	8/12-QFN/SON	✓	Fault indication	0.35
bq24314C	30	5.85	Prog. <1.5 A	4.45	—	600	8/12-QFN/SON	✓	Fault indication	0.35
bq24315	30	5.85	Prog. <1.5 A	4.35	5.5	600	8-QFN/SON	✓	Fault indication	0.35
bq24316	30	6.8	Prog. <1.5 A	4.35	—	600	8/12-QFN/SON	✓	Fault indication	0.35
bq24380	30	6.3	No OCP	4.35	5.5	250	8-QFN/SON	✓	Fault indication	0.25
bq24381	30	7.1	No OCP	4.35	5	300	8-QFN/SON	✓	Fault indication	0.25
bq24382	30	10.5	No OCP	4.35	5	300	8-QFN/SON		Fault indication	0.25
bq24350	30	6.17	Fixed 1.2 A	4.35	5.5	500	8-QFN/SON	✓	Integrated charge FET	0.40
bq24351	30	10.5	Fixed 1.2 A	4.35	6.38	500	8-QFN/SON	✓	Integrated charge FET	0.40
bq24352	30	7.1	Fixed 1.2 A	4.35	5.5	500	8-QFN/SON	✓	Integrated charge FET	0.40

\*Suggested resale price in U.S. dollars in quantities of 1,000.



# Battery Management Products

## Battery Fuel Gauges—Single-Cell Solutions

### Design Factors

**Battery Chemistry** — Each battery chemistry has different operating characteristics, such as discharge profiles and the self-discharge rate. The battery chemistry is programmed in the dataflash of the TI fuel gauge to account for these differences. In addition, the conditions of the end-equipment system can be programmed in the gas gauge. Designers can choose to implement the

gauge in the host system or inside the battery pack. The programmed information is processed in TI's Impedance Track™ gauging technology for prediction of remaining battery capacity with >99% accuracy.

### Features

TI gas gauges and battery monitors accurately track battery activity to compute the remaining battery capacity

and system run-time. The following features are available:

- Patented Impedance Track battery fuel-gauging technology for >99% accuracy
- System- and pack-side implementation
- Turnkey solution with complete CPU and battery fuel-gauge firmware
- Interrupt-driven gas gauge signaling the host with the battery's specific state-of-charge status
- Gas gauge with integrated LDO in small packages

## System-Side Impedance Track™ Fuel Gauge with Integrated LDO

### bq27520

The bq27520 is a high-performance, system-side fuel gauge with excellent accuracy, low power consumption and extremely small package size. By integrating the fuel-gauge function into the system board, portable-equipment designers can use an embedded or removable standard battery pack while adding the capability to accurately display remaining pack capacity and estimated run time. The bq27520 features an integrated voltage regulator that reduces the total component count for the system.

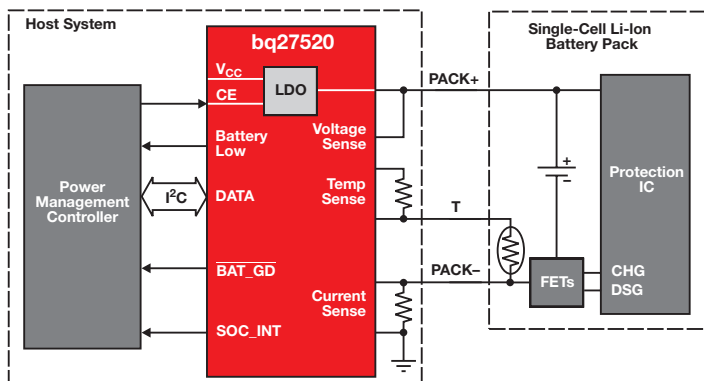

The bq27520 also has an interrupt-generation capability that reduces the software burden on the system processor because the fuel gauge does not require repetitive polling from the host.

The bq27520 uses the patented Impedance Track algorithm for fuel gauging and provides information such as remaining battery capacity, state of charge, minimum run time to empty, battery voltage, temperature and state of health. Battery fuel gauging with the bq27520 requires only PACK+ (P+), PACK- (P-) and thermistor (T) connections to a removable battery pack or embedded battery circuit.

Get more information: [www.ti.com/product/bq27520](http://www.ti.com/product/bq27520)

### Selection Guide

Device	Approx. Battery Capacity (mAh)	Min Max Series Cell	SHA-1 Authentication	System or Pack	Communication Protocol	Other Features	Package	Price*
<b>Lithium-Ion, Lithium-Polymer Chemistry</b>								
<b>bq27010</b>	300 to 6000	1	No	Pack	HDQ	Fuel gauge with compensated-voltage EOD	10-pin DRK	1.25
<b>bq27210</b>	300 to 6000	1	No	Pack	I <sup>2</sup> C	Fuel gauge with compensated-voltage EOD	10-pin DRK	1.25
<b>bq27500</b>	300 to 6000	1	No	System	I <sup>2</sup> C	System-side fuel gauge with Impedance Track™ technology	12-pin QFN	1.35
<b>bq27510</b>	300 to 6000	1	No	System	I <sup>2</sup> C	System-side fuel gauge with Impedance Track technology with integrated LDO	12-pin QFN	1.45
<b>bq27541</b>	300 to 6000	1	Yes	Pack	I <sup>2</sup> C/HDQ	Pack-side fuel gauge with Impedance Track technology	12-pin QFN	1.45
<b>bq27545</b>	300 to 6000	1	Yes	Pack	I <sup>2</sup> C/HDQ	Pack-side fuel gauge with Impedance Track technology	12-pin QFN	1.45
<b>bq27501</b>	300 to 6000	1	No	System	I <sup>2</sup> C	System-side fuel gauge with Impedance Track technology with battery ID resistor	12-pin QFN	1.35
<b>bq27505</b>	300 to 6000	1	No	System	I <sup>2</sup> C	System-side fuel gauge with Impedance Track technology	12-ball CSP	1.40
<b>bq27520</b>	300 to 6000	1	No	System	I <sup>2</sup> C	System-side fuel gauge with Impedance Track technology with integrated LDO	15-ball CSP	1.50
<b>bq27410</b>	300 to 6000	1	No	System	I <sup>2</sup> C	System-side fuel gauge with Impedance Track Lite technology with integrated LDO	12-pin QFN	1.40
<b>bq27425</b>	300 to 6000	1	No	System	I <sup>2</sup> C	System-side fuel gauge with Impedance Track Lite technology with integrated sense resistor	15-ball CSP	1.40
<b>bq28z560</b>	300 to 8000	1	Yes	Pack	SMBus/HDQ	Pack-side fuel gauge with Impedance Track technology	12-pin QFN	3.15
<b>bq28550</b>	300 to 6000	1	Yes	Pack	SMBus	Pack-side fuel gauge with CEDV technology with integrated LDO	12-pin QFN	2.90

\*Suggested resale price in U.S. dollars in quantities of 1,000.

Preview devices are listed in bold teal.

# Battery Management Products

## Battery Fuel Gauges—Multi-Cell Solutions

### Design Factors

**Battery Chemistry** — Each battery chemistry has different operating characteristics, such as discharge profiles and self-discharge rate. TI gas gauge ICs are developed by chemistry to account for these differences to accurately display remaining energy in the battery.

### Features

TI gas gauges and battery monitors accurately track battery activity to compute the remaining battery capacity and system run-time. They feature:

- Simple communication protocols.
- High-resolution analog-to-digital converters for accurate charge/discharge measurement.

- Integrated CPU on gas gauges to compute remaining battery capacity and run-time.
- Advanced charge management satisfies JEITA specification of variable charging current and voltage with battery conditions.

### 99% Accurate Gas Gauge Maximizes Run-Time

#### bq20z65-R1

The dynamic Impedance Track™ gas gauge algorithm in the bq20z65 extends battery usability, allowing use of the full chemical capacity available in a battery pack. Additional features include instant state-of-charge and real-time impedance learning. Impedance Track also enables reduction in development and production time. Remaining capacity is reported over the entire life of the battery pack with better than 99% accuracy. The bq20z65-R1 is well-suited for battery packs used in medical and industrial equipment, back-up batteries and laptop computers.

Get more information:

[www.ti.com/product/bq20z65-R1](http://www.ti.com/product/bq20z65-R1)

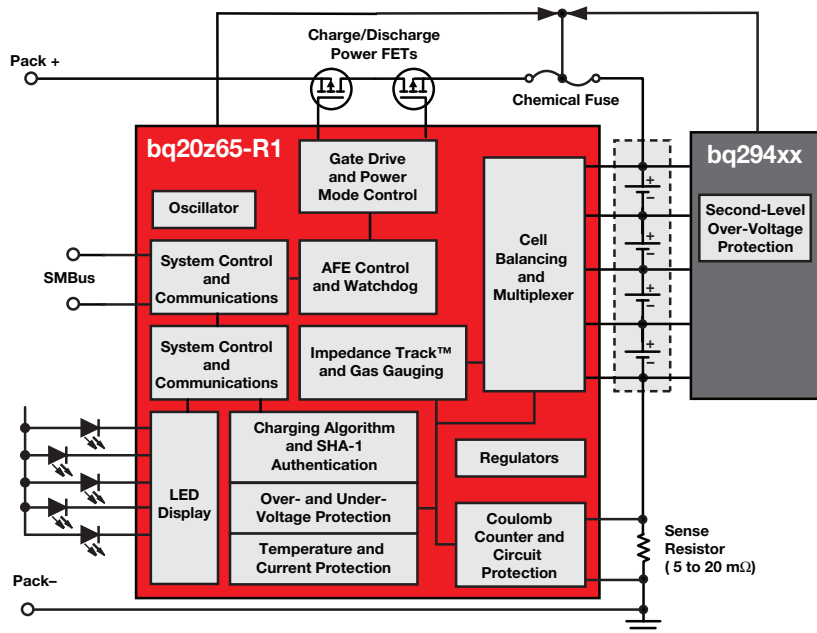

Example of single-chip solution (gas gauge plus integrated AFE).

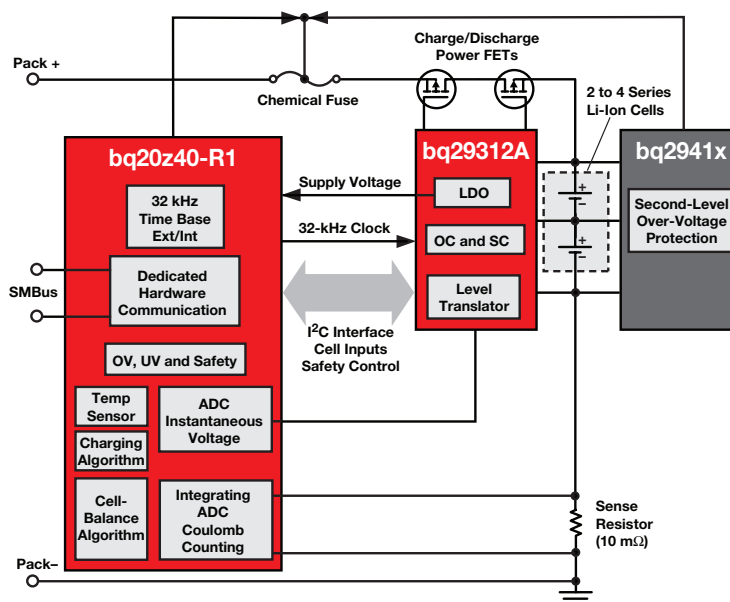

Example of two-chip solution (gas gauge plus AFE).

# Battery Management Products

## Battery Fuel Gauges—Multi-Cell Solutions

### Multi-Cell Fuel Gauges Selection Guide

Device	Approx. Battery Capacity (mAh)	Min Max Series Cell	Number of LEDs	Communication Protocol	Other Features	Package	Price*
<b>NiCd, NiMH Chemistry</b>							
bq2013H	2000 to 15000	—	5	Single wire (HDQ)	Programmable offset error compensation	16-pin SOIC	3.70
bq2014H	500 to 6000	—	5	Single wire (HDQ)	Register compatible with bq2050H	16-pin SOIC	4.60
bq2016	1000 to 4500	—	5	Single wire (HDQ)	Automatic offset calibration	28-pin SSOP	3.75
<b>Lithium-Ion, Lithium-Polymer, LiFePO<sub>4</sub> Chemistry</b>							
bq28400	500 to 16000	2	—	SMBus	CEDV+ gas gauge with integrated protector	20-pin TSSOP	3.20
bq3050	500 to 32000	2 to 4	3, 4 or 5	SMBus	CEDV+ gas gauge with integrated protector	38-pin TSSOP	3.55
bq3055	500 to 32000	2 to 4	—	SMBus	CEDV+ gas gauge with integrated protector	30-pin TSSOP	3.90
bq3060	500 to 32000	2 to 4	—	SMBus	CEDV+ gas gauge with integrated protector	24-pin TSSOP	3.55
bq20z40	800 to 32000	2 to 4	—	SMBus	Impedance Track™ fuel gauge for use with bq29330 protector	20-pin TSSOP	3.65
bq20z45-R1	800 to 32000	2 to 4	—	SMBus	Impedance Track fuel gauge with integrated protector	38-pin TSSOP	4.45
bq20z60-R1	800 to 32000	2 to 4	3, 4 or 5	SMBus	Impedance Track fuel gauge with LED for use with bq29330 protector	30-pin TSSOP	3.90
bq20z65-R1	800 to 32000	2 to 4	3, 4 or 5	SMBus	Impedance Track fuel gauge with LED and integrated protector	44-pin TSSOP	4.75
bq20z655-R1	800 to 32000	2 to 4	3, 4, 5 or LCD	SMBus	Impedance Track fuel gauge with LED or LCD and integrated protector	44-pin TSSOP	5.20
bq34z100	65000 and above	1 to 16	4	I <sup>2</sup> C or HDQ	Wide-range fuel gauge with Impedance Track technology	14-pin TSSOP	2.50
bq34z651	800 to 32000	2 to 4	3, 4 or 5	SMBus	Gas gauge and protection enabled with Impedance Track and external battery heater control	44-pin TSSOP	5.20
<b>Lead Acid Chemistry</b>							
bq34z110	65000 and above	1 to 16	4	I <sup>2</sup> C or HDQ	Wide-range fuel gauge with Impedance Track technology	14-pin TSSOP	3.90
<b>Multi-Chemistry</b>							
bq2060A	800 to 10000	2 to 4	5	SMBus or HDQ	Most accurate multi-chemistry gauge from TI	28-pin SSOP	3.90
<b>Super Cap</b>							
bq33100	—	2 to 5	—	SMBus	Fully integrated 2, 3, 4 and 5 series super capacitor manager	24-pin TSSOP	4.20
<b>Battery Monitors</b>							
bq2019	>20000	—	—	Single wire (HDQ)	64-bit ID ROM and 1 program output non-volatile memory	8-pin TSSOP	1.95
bq2023	>20000	—	—	Single wire (SDQ™)	64-bit ID ROM and 1 program output automatic offset error calibration	8-pin TSSOP	2.00
bq26200	>20000	—	—	Single wire (HDQ)	High-performance battery, coulomb counter	8-pin TSSOP	2.00
bq26220	>20000	—	—	Single wire (HDQ)	64-bit ID ROM and 1 program output on-chip voltage measurement	8-pin TSSOP	2.05
bq76PL536A	—	3 to 192	—	SPI	3- to 6-cell EV and UPS stackable monitor and cell-balancing AFE	64-pin HTQFP	4.30

\*Suggested resale price in U.S. dollars in quantities of 1,000.

### Battery Fuel Gauges Family of Products

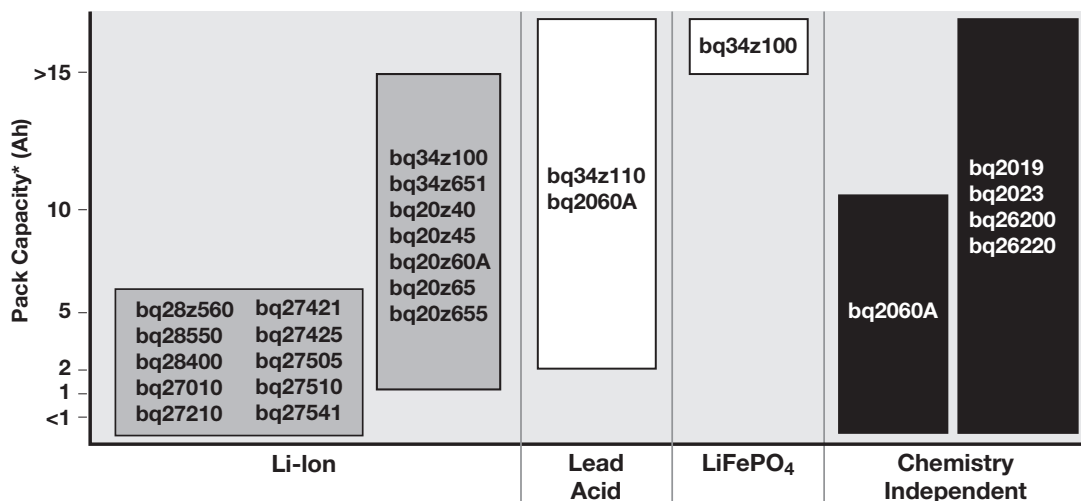

\*Pack capacity ratings provide an approximate range for each gas gauge.

For a complete list of Resources, visit: [www.ti.com/battery](http://www.ti.com/battery)

# Battery Management Products

## Battery and Peripheral Authentication

### Design Factors

Original equipment manufacturers specify products to achieve required performance and safety goals. Authentication ensures that connected devices fulfill the established requirements and are safe for the consumer.

### Features

TI authentication devices use three levels of security.

- **Identification Number** — The host controller can request an identification number that is answered with a fixed response.
- **CRC Algorithm** — The host processor sends a random challenge and reads the response that is an encoding of the challenge and a shared secret key through a CRC with a shared secret polynomial.
- **SHA-1 Encryption** — The host processor sends a random challenge and reads the response that is an encoding of the challenge and a shared secret key through the SHA-1 cryptographic primitive.

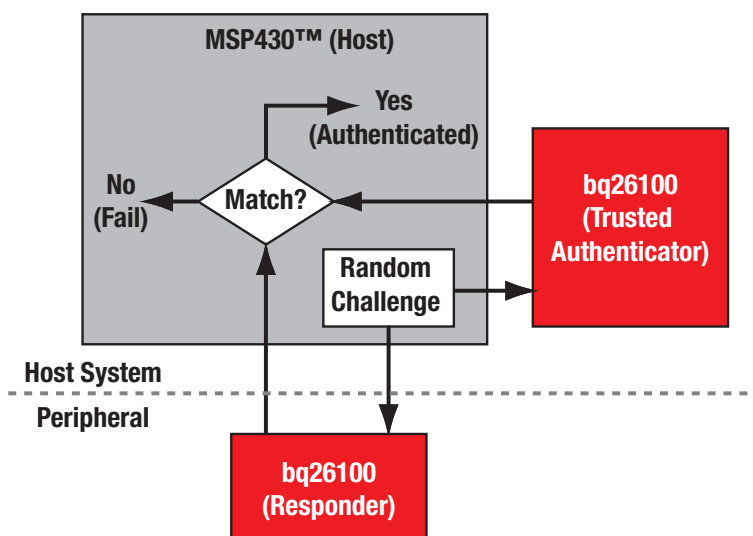

Single-cell battery pack with gas gauge and authentication.

### Selection Guide

Device	Interface	Pins	Security	Temp (°C)	Price*
bq2022A	SDQ™	3	ID number	-40 to 85	0.90
bq2024	SDQ	3	ID number	-40 to 85	0.95
bq26150	HDQ	5	CRC algorithm	-20 to 70	0.95
bq26100	SDQ	5	SHA-1 encryption	-20 to 70	0.99
bq27541	I <sup>2</sup> C/HDQ	12	SHA-1 encryption	—	1.45

\*Suggested resale price in U.S. dollars in quantities of 1,000.

# Battery Management Products

## Battery (Li-Ion) Protection Solution

### Design Factors

**Number of Series Cells** — A battery pack is constructed from a string of series and parallel cells. Each series cell, or group of parallel cells, requires protection from overcharge, overdischarge and short-circuit conditions.

**Threshold Voltage** — Li-Ion and Li-Polymer cells are produced by many manufacturers. Some manufacturers' technologies create cells of different maximum stress voltages, otherwise

known as the "overvoltage threshold." This data is available from the cell supplier.

**Threshold Tolerance** — The overvoltage threshold has a tolerance to be accounted for in the design for safety reasons.

**Shutdown Current** — In battery pack applications, constant current draw needs to be very low to preserve battery life.

**Charge/Discharge Current** — The pass element associated with each protection IC is rated for maximum current whether it be an internal or external FET.

### Features

- BiCMOS process results in low current consumption.
- Different overvoltage thresholds allow one design to work with several cell suppliers.
- Sleep current consumption of less than 3.5  $\mu\text{A}$  enables extended battery life.
- 50 mV precision internally trimmed thresholds maximize safety.
- Short-circuit protection eliminates the need for an external fuse.

## Stand-Alone Multi-Cell Precision Protector for Li-Ion Chemistries

### bq77910A

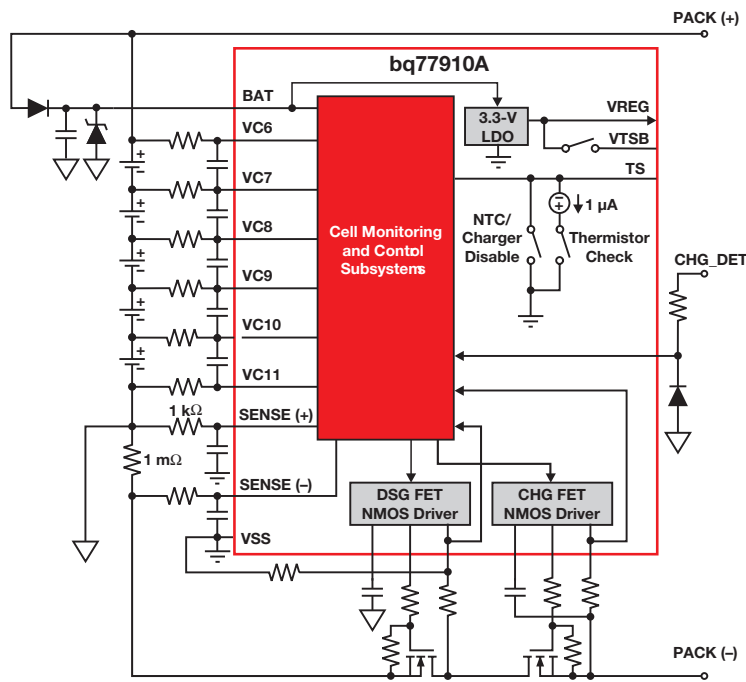

5-cell, series FET configuration schematic using the bq77910A.

The bq77910A precision protector is a complete stand-alone, self-contained battery-protection and cell-balancing device intended for Li-Ion/Li-Polymer battery packs.

### Key Features

- 4-, 5-, 6-, 7-, 8-, 9- or 10-series cell protection
- Individual cell-voltage monitoring
- Low-side NMOS FET drive for charge and discharge control
- Compatible with 1-m $\Omega$  current-sense resistor
- Supply-voltage range: 5.6 V to 50 V
- Integrated 3.3-V micropower LDO

Get more information:

[www.ti.com/product/bq77910A](http://www.ti.com/product/bq77910A)

### Selection Guide

Device	Number of Series Cells	Charge/Discharge Current (A)	Shutdown Current ( $\mu\text{A}$ )	Other Features	Package(s)	Price*
bq2920x	2	—	3	Overvoltage safety with cell balancing	8-pin SON	0.30
bq2941x	2, 3 or 4	—	3	Overvoltage safety for chemical fuse activation; PTC	8-pin TSSOP	0.45
bq2944x	2, 3 or 4	—	3	Overvoltage safety for chemical fuse activation	8-pin SON	0.45
bq2945xy	2 or 3	—	4	Overvoltage safety for chemical fuse activation	6-pin SON	0.40
bq2946xy	1	—	4	Overvoltage safety for chemical fuse activation	6-pin SON	0.38
bq76925	3 to 6	—	1	Host-controlled protector with cell balancing	20-pin TSSOP, 24-pin QFN	1.50
bq77PL900	5 to 10	External PFET	—	Stand-alone or host-controlled protector with cell balancing	48-pin SSOP	2.95
bq77908A	4 to 8	External NFET	5	Stand-alone protector with cell balancing	38-pin TSSOP	2.70
bq77910A	4 to 10	External NFET	5	Stand-alone protector with cell balancing	38-pin TSSOP	2.70
bq77PL157A4225	3 to 6	External NFET	3	Stackable overvoltage protector; stack 3 for 18 series cells	16-pin TSSOP	0.65

\*Suggested resale price in U.S. dollars in quantities of 1,000.

# Battery Management Products

## Wireless Power

### Overview

The market demand for the convenience and safety of standards-compliant wireless power systems continues to grow rapidly. While near-field inductive power coupling has been around for some time, applications have been limited to very low power levels. With increasing power demands in addition to the need for advanced control systems in higher-power batteries, a number of safety risks in the design of wireless power systems must be considered. Compliance with standards specifications, such as those of the Wireless Power Consortium (WPC), helps designers avoid safety problems and ensures interoperability between systems. With the right products and tools to help customers quickly bring new products to market, TI is actively making wireless power a reality.

### Operation

A basic wireless power system consists of a power transmitter (Tx) and receiver (Rx). The Tx is typically located in a base station powered by an AC line or other stable power source. The Rx is located in a battery-powered device that uses received power to charge a battery. Both Tx and Rx contain wire coils and power is transferred between them without electrical contact via inductive coupling. Since power is inductively transferred via coils, the Tx must power the coil with a switching current that has sufficient frequency to optimize

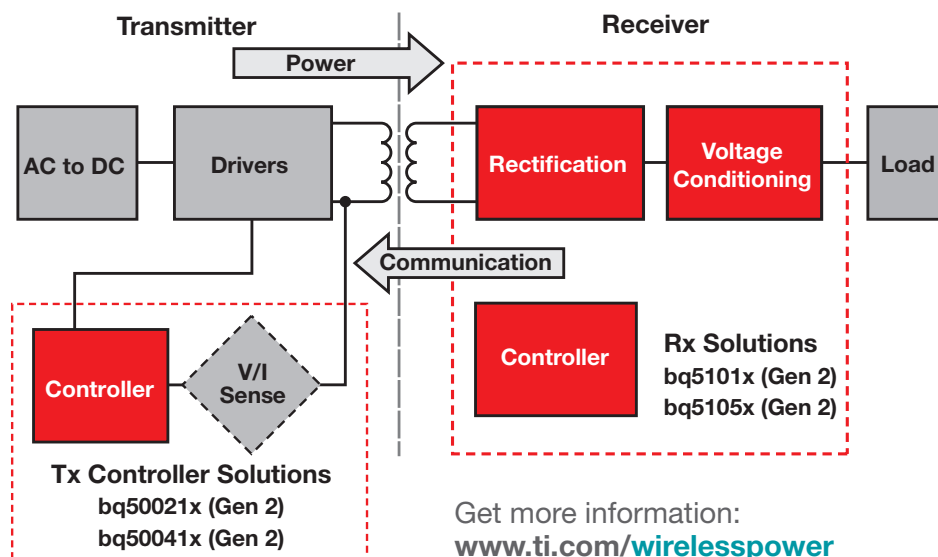

coupling between coils. The Rx coil then picks up the near-field inductive energy and uses rectifiers and voltage-conditioning circuitry to produce a DC output. To control the power transfer, the Rx constantly communicates with the Tx to indicate when power is required, how much power to send, and when to stop sending power. This communications data is exchanged through the same coils that couple the power.

### Differentiate Your Design

TI delivers a broad portfolio of products and advanced technologies to bring you the right wireless power solutions. The bqTESLA™ family of transmitter and receiver ICs and a wide selection of battery charger and protection products

ensure robust power solutions. All products include an extensive selection of support collateral such as development tools, technical documentation and reference designs. There is also application expertise and support to simplify your design process and speed time to market. The following pages provide more details on these devices and tools.

### Receiver-Side Solutions

TI's Qi-compliant receivers integrate a low-impedance, full synchronous rectifier, a low-dropout regulator (LDO), digital control and accurate voltage and current loops. The entire power stage (rectifier and LDO) utilize low-impedance NMOS FETs to ensure high efficiency and low power dissipation.

## Receiver Selection Guide

(Device parameters continued on next page)

Device	Number of Cells	V <sub>IN</sub> Type	V <sub>IN</sub> Max Operating (V)	V <sub>IN</sub> Absolute Max (V)	V <sub>IN</sub> OVP (V)	Charge Current (A)	Charge Voltage (V)	Control Interface	Topology	Integrated Power FET
bq51011	Reg V <sub>OUT</sub>	Coil/USB/Adapter	10	20	15	See Comments	5	Stand Alone	Linear	Yes
bq51013	Reg V <sub>OUT</sub>	Coil/USB/Adapter	10	20	15	1.5	5	Stand Alone	Linear	Yes
bq51013A	Reg V <sub>OUT</sub>	Coil/USB/Adapter	10	20	15	1.5	5	Stand Alone	Linear	Yes
bq51013B	Reg V <sub>OUT</sub>	Coil/USB/Adapter	10	20	15	1.5	5	Stand Alone	Linear	Yes
bq51050B/51B	Reg V <sub>OUT</sub>	Coil/USB/Adapter	10	20	15	1.5	5	Stand Alone	Wireless Battery Charger	Yes

# Battery Management Products

## Wireless Power

### Integrated, Qi-Compliant, Wireless Power-Supply Receivers

**bq51013B, bq51050B, bq51051B**

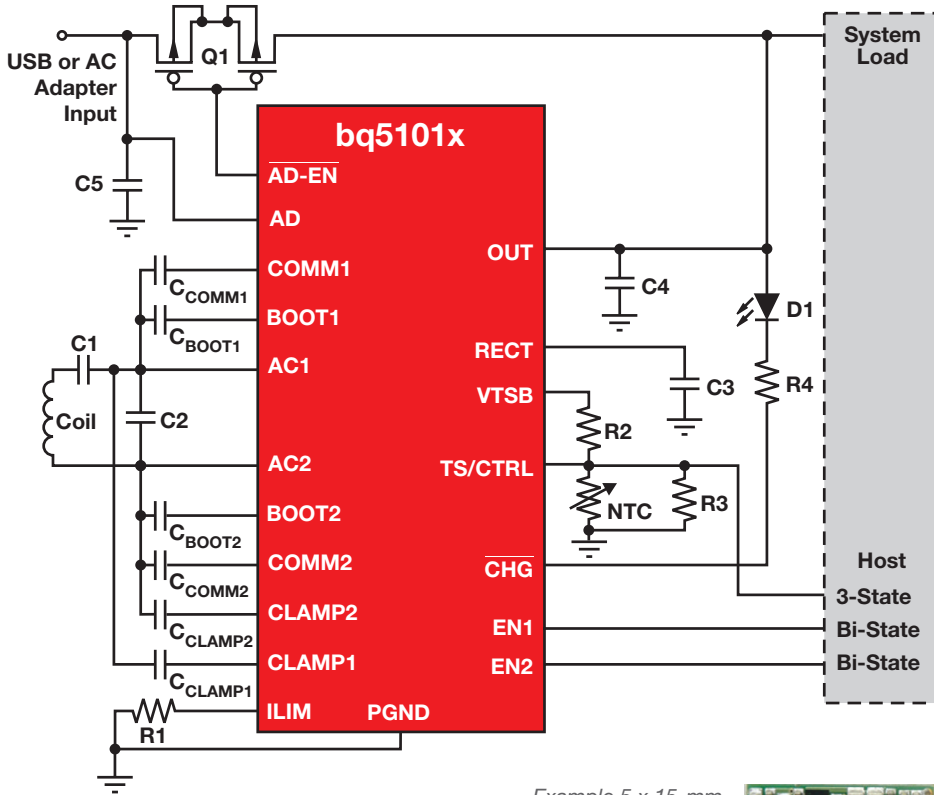

Example 5 x 15-mm PCB with all receiver side circuitry.

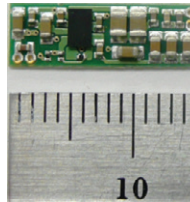

#### Key Features

- Integrated wireless power receiver with a 5-V regulated supply
- 93% overall peak AC-to-DC efficiency
- Full synchronous rectifier
- WPC v1.0-compliant communication control
- Output-voltage conditioning
- Only IC required between Rx coil and 5-V DC output voltage
- Internal Dynamic Rectifier Control™ for improved load-transient response
- Supports 20-V maximum input
- Low-power dissipative rectifier over-voltage clamp ( $V_{OVP} = 15\text{ V}$ )
- Thermal shutdown
- Single NTC/control pin
- Packaging
  - 1.9x3-mm WCSP
  - 4.5x3.5-mm QFN (Coming soon)

#### Applications

- Cell and smartphones
- Headsets
- Digital cameras
- Portable media players
- Handheld devices

Get more information: [www.ti.com/product/bq51013B](http://www.ti.com/product/bq51013B), [bq51050B](http://www.ti.com/product/bq51050B) or [bq51051B](http://www.ti.com/product/bq51051B)

(Device parameters continued from previous page)

Device	Primary Charge Termination	Charge Timer	Temperature Monitor	Packaging		EVM	Comments	Price*
				WCSP	QFN/MLP			
<b>bq51011</b>	EPT Cmd to Tx	No	Yes	28			Receiver, current limited charge current (400 mA + dynamic $I_{LIM}$ )	3.50
<b>bq51013</b>	EPT Cmd to Tx	No	Yes	28		✓	Receiver, regulated voltage output, compliant to WPC specification 1.0	3.50
<b>bq51013A</b>	EPT Cmd to Tx	No	Yes	28	20	✓	WPC 1.0 receiver, regulated voltage output, dynamic efficiency control, dynamic communications limit	3.50
<b>bq51013B</b>	EPT Cmd to Tx	No	Yes	28	20	✓	WPC 1.1 receiver, regulated voltage output, dynamic efficiency control, dynamic communications limit	2.50
<b>bq51050B/51B</b>	EPT Cmd to Tx	No	Yes	28	20	✓	WPC 1.1 receiver, regulated voltage output, dynamic efficiency control, dynamic communications limit, built-in Li-Ion charging	2.75

\*Suggested resale price in U.S. dollars in quantities of 1,000.

New devices are listed in **bold red**.

# Battery Management Products

## Wireless Power

### Transmitter-Side Solutions

TI offers dedicated digital controllers that integrate the logic functions required to control wireless power transfer in a single-channel, WPC-compliant, contactless-charging base station. These intelligent controllers periodically ping the

surrounding environment for available devices to be powered, monitor all communication from the device being wirelessly powered, and adjust power applied to the transmitter coil per feedback received from the powered device. They also monitor transfer

efficiency with real-time analysis, which protects the controllers and power receivers from excessive power loss and heat associated with parasitic metal objects placed in the power-transfer path.

### Qi-Compliant, Wireless Power-Transmitter Manager

#### bq500410A

Together with the bq5101x receivers, the bq500410A transmitter controller enables a complete, contactless power-transfer system for a wireless power-supply solution.

#### Key Features

- Intelligent control of the power transfer between base station and mobile device
- Conforms to WPC v1.1 A6 transmitter specification
- Expanded free positioning using a three-coil transmit array
- Digital demodulation to reduce components
- Parasitic metal-object detection (PMOD) and foreign-object detection (FOD)
- LED indication of charging state and fault status
- Overload and overtemperature protection
- 7 x 7-mm, 48-pin QFN package

#### Applications

- Transmitter pad for contactless charging with WPC compliance
- Low-power (<5-W) end equipment: Cell phones, digital cameras, portable media players, remote/gaming controllers, *Bluetooth*® headsets and other portable devices

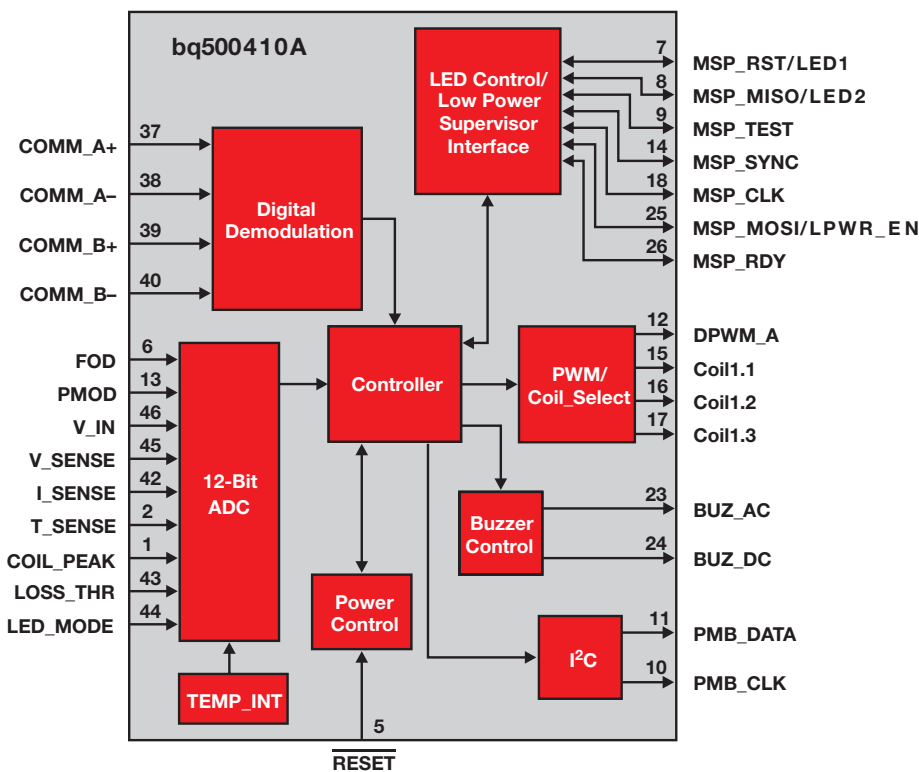

Get more information: [www.ti.com/product/bq500410A](http://www.ti.com/product/bq500410A)

### Transmitters Selection Guide

Device	Transmitter Type	V <sub>IN</sub> (V)	Magnet	Key Features	Price*
<b>bq500410A</b>	A6	12	No	1 to 3 coils, large charging area, WPC 1.1 ready	2.85
<b>bq500211A</b>	A5	5	Yes	Power from low-cost 5-V adapter or USB port, WPC 1.1 ready	2.85
	A11	5	No		
<b>bq500210</b>	A1	19	Yes	Second-generation solution with digital demodulation to reduce component count	2.62
	A10	19	No		

\*Suggested resale price in U.S. dollars in quantities of 1,000.

New devices are listed in **bold red**.



# Battery Management Products

## Wireless Power

### bqTESLA™ Development Modules

TI's combined bqTESLA evaluation modules provide a high-performance, easy-to-use development kit for the design of low-power wireless solutions. The kit features the bq500410A with three coils for free positioning and the bq51013A power-supply receiver, which enables designers to speed their development time.

### WPC 1.1 Compliant, 12-V Free-Positioning, Wireless Power Transmitter Evaluation Module

#### bq500410AEVM-085

The bq500410AEVM-085 evaluation module (EVM) provides all major functions for evaluation of the bq500410A IC in a fully functional WPC A6 type wireless transmitter.



bq500410A evaluation module

#### Key Features

- Transmitter mounting pad to provide correct receiver interface
- Receiver output up to 5 W
- Standard A6-type transmitter coil
- Option to configure an external buzzer

Get more information at: [www.ti.com/tool/bq500410AEVM-085](http://www.ti.com/tool/bq500410AEVM-085)

### WPC 1.1 Compatible, Integrated Wireless Power Receiver Evaluation Module

#### bq51013EVM-725

The bq51013EVM-725 Wireless Power Receiver evaluation module (EVM) is a high-performance, easy-to-use development tool for the design of wireless power transfer in portable applications. The EVM provides AC/DC power conversion while integrating the digital control required to comply with the communication protocol.



bq51013 evaluation module

#### Key Features

- Integrated WPC-certified receiver with a 5-V regulated supply
- Dynamic Rectifier Control™ for improved load transient response
- Supports 20-V maximum input
- Low-power dissipative rectifier over-voltage clamp ( $V_{OVP} = 15\text{ V}$ )
- Thermal shutdown
- Single NTC/control pin for optimal safety and I/O with host

Get more information at: [www.ti.com/tool/bq51013EVM-725](http://www.ti.com/tool/bq51013EVM-725)

# LED Lighting

## General Illumination

LED technologies continue to improve and to produce more light while using less power at lower costs. This trend is fueling flexible, creative and cost-effective solid-state lighting (SSL).

Solid-state LED lighting applications include retrofitted lightbulb replacement, high-bay and street lighting, and fully customized luminaires. Key considerations can include:

- Superior light quality as compared to traditional light sources
- Existing form factor and socket compatibility

- Supply voltage (AC or DC)
- Legacy dimmer compatibility and dimming performance
- High efficiency and long operating life
- Power factor
- Conducted and radiated emissions

Solving these challenges requires a wide variety of LED lighting solutions.

**AC/DC LED Drivers** — TI offers AC/DC driver solutions for LED lighting systems that are dimmable, isolated and non-isolated, highly efficient and power-factor-corrected with a long-life and a

compact form factor. These LED systems can also maintain compatibility with installed fixtures and dimmers. Driver protection features such as over-voltage, over-current and over-temperature ensure that LED lighting products are safer than the traditional bulbs they replace.

**DC/DC LED Drivers** — TI offers DC/DC lighting-driver solutions with wide input/output operating ranges that can be used in buck, boost, SEPIC and flyback architectures. Small solution sizes facilitate 12- to 24-V retrofitted designs such as MR-16.

Get more information at: [www.ti.com/led](http://www.ti.com/led)

### Phase-Dimmable, Primary-Side Regulated, PFC Flyback Controller for LED Lighting

#### LM3447

The LM3447 AC/DC LED driver includes TRIAC and trailing-edge dimmer detect and decoder. It also has an adjustable hold-current circuit to provide smooth and flicker-free dimming operation in off-line and isolated LED lighting applications. Using constant power control, lighting solutions based on the LM3447 can achieve up to 10% improvement in efficacy across the expected operating temperature range of the fixture.

#### Applications

- Dimmable lamps: A19, E26/27, PAR38
- LED luminaires

#### Evaluation Modules

Part Number	Description
LM3447-A19-120VEVM	LM3447 120-VAC, 10-W, A19 evaluation module
LM3447-A19-230VEVM	LM3447 230-VAC, 10-W, A19 evaluation module
LM3447-PAR-230VEVM	LM3447 230-VAC, 16-W, PAR38 evaluation module

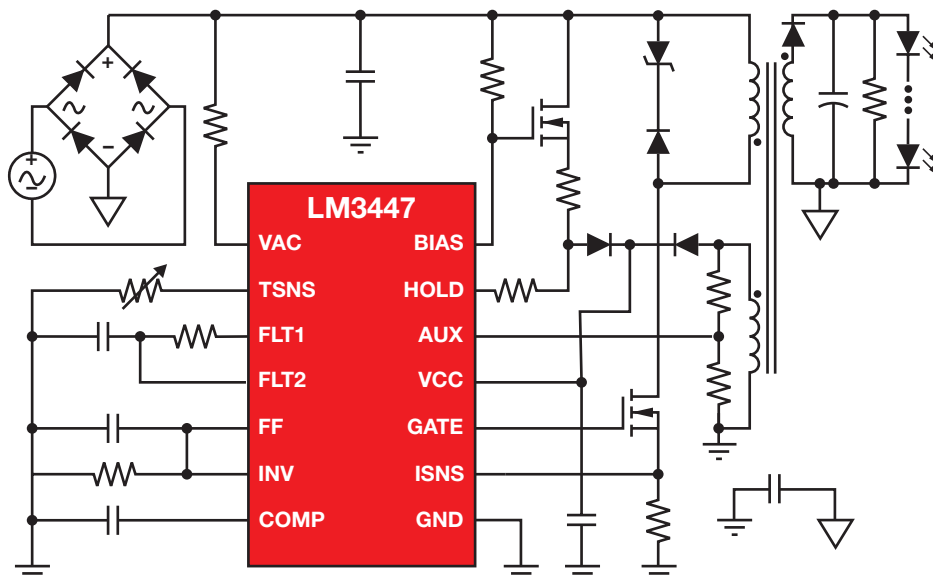

Get more information: [www.ti.com/product/LM3447](http://www.ti.com/product/LM3447)

# LED Lighting

## General Illumination

### Non-Isolated, Phase-Dimmable, Buck-PFC LED Driver with Digital Reference Control

**NEW**

#### TPS92075

The TPS92075 is a hybrid power-factor controller with a built-in phase-dimming decoder. Power factor correction (PFC) is implemented using propriety control of the internal reference. The controller operates in two modes: High power factor and dimming. During non-dimming, the reference is controlled to maximize power factor. When dimming is sensed, the reference is controlled in relation to a dimming curve that has been optimized for TRIAC compatibility. The power stage operates with peak current/constant off-time hysteretic control with variable switching frequency. These integrated features simplify design with minimal external components. The TPS92075 includes standard protection features of input UVLO, LED open/short detection, as well as IC thermal shutdown. The available package options include 8-pin SOIC and 6-pin TSOT.

#### Applications

- 5- to 30-W LED luminaires/lamps
- Phase-dimmable retrofit LED lighting (A19, PAR/BR, T8)
- Recessed LED downlights, pendant lights

#### Evaluation Module

Part Number	Description
TPS92075EVM	TPS92075 120-VAC, 12.6-W A19 evaluation module

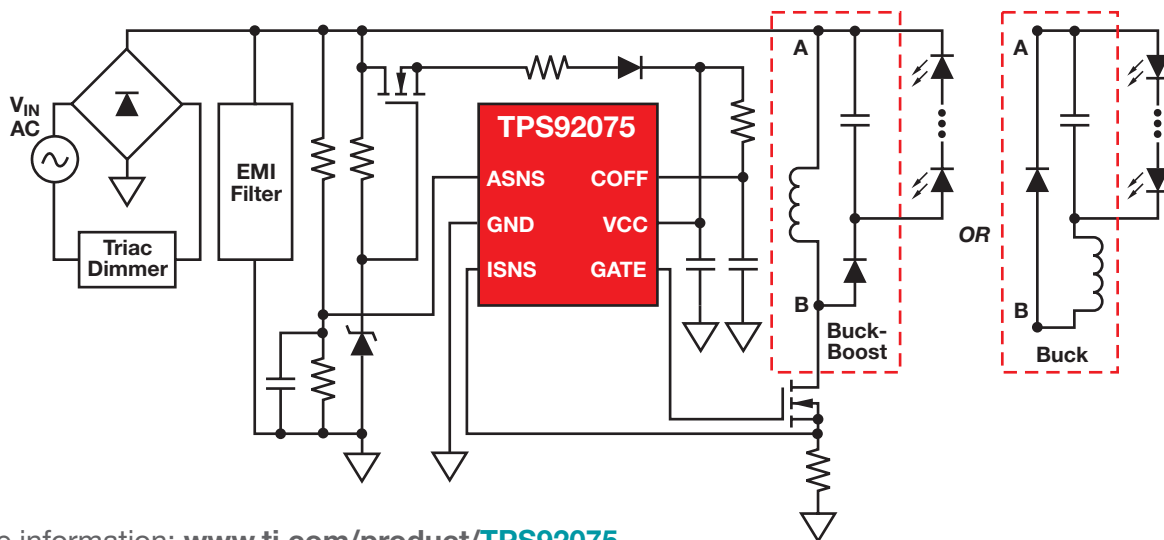

Get more information: [www.ti.com/product/TPS92075](http://www.ti.com/product/TPS92075)

# LED Lighting

## General Illumination

### 450-mA, Constant-Current Buck, LED Driver Micro-Modules

#### TPS92550, TPS92551

The 14-W TPS92550 and 23-W TPS92551 are integrated constant-current buck, LED driver modules that require only one external capacitor to implement a 350-mA constant-current source for driving high-brightness LEDs. The drivers work seamlessly with readily available and inexpensive off-the-shelf constant-voltage power supplies to perform the conversion from constant voltage to constant current that is needed to properly drive

LEDs. Using this approach, a complete lighting solution can be implemented in minutes. The TPS92550/1 LED-driver micro-modules integrate all the power components (including the power inductor) and can drive 450-mA maximum LED current for up to 10 (TPS92550) or 16 (TPS92551) LEDs in a single string.

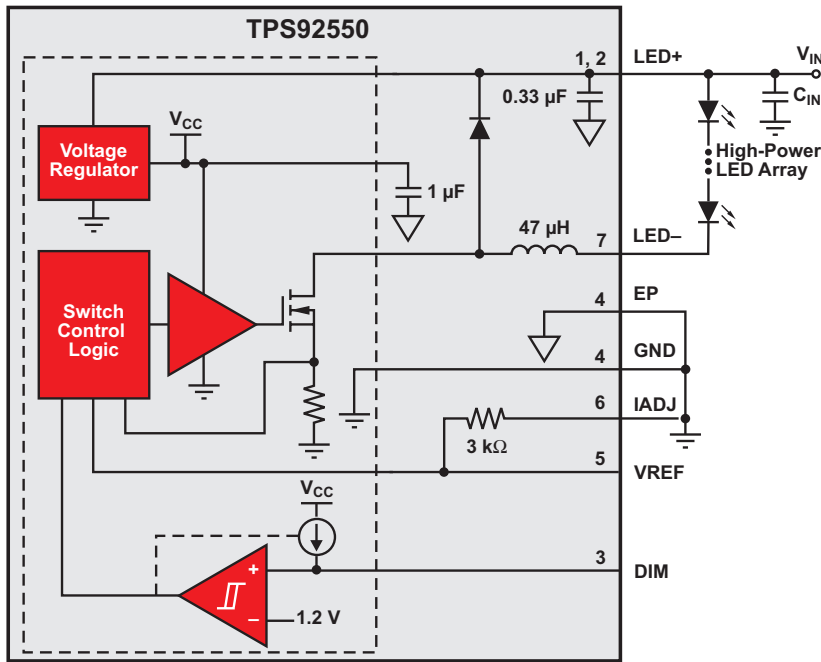

### Key Parameters

Device	V <sub>IN</sub>	f <sub>SW</sub>
TPS92550	4.5 to 36 V	400 kHz
TPS92551	4.5 to 60 V	800 kHz

### LED Current Setting

IADJ Pin	VREF Pin	I <sub>LED</sub> Current
499 Ω	Open	300 mA
Ground	Open	350 mA
Ground	10.5 kΩ	450 mA

### Evaluation Modules

Part Number	Description
TPS92550EVM	TPS92550 evaluation module
TPS92551EVM	TPS92551 evaluation module

Get more information: [www.ti.com/product/TPS92550](http://www.ti.com/product/TPS92550) or [TPS92551](http://www.ti.com/product/TPS92551)

### Selection Guide

Device	V <sub>IN</sub> (min) (V)	V <sub>IN</sub> (max) (V)	LED Voltage (max) (V)	Switching Frequency (kHz)	DC/DC or AC/DC Control	Isolated Applications	Non-Isolated Applications	Topology	LED Configuration	Dimming	PFC	EVM	Package(s)	Price*
<b>AC/DC High-Brightness LED Drivers</b>														
<b>TPS92001</b>	9	19	Configurable	100	AC/DC	✓	✓	Flyback/Buck	Series/Parallel	TRIAC	✓		8 MSOP, 8 SOIC	0.45
<b>TPS92002</b>	14	19	Configurable	100	AC/DC	✓	✓	Flyback/Buck	Series/Parallel	TRIAC	✓		8 MSOP, 8 SOIC	0.45
<b>TPS92020</b>	11.5	18	Configurable	350	DC/DC	✓	✓	Half-Bridge	Multi-String Series/Parallel	PWM		✓	8 SOIC	0.70
<b>TPS92210</b>	9	20	Configurable	140	AC/DC	✓	✓	Flyback	Series/Parallel	TRIAC	✓	✓	8 SOIC	0.75
<b>TPS92075</b>	11	18.5	Configurable	500	AC/DC	✓	✓	Buck/Buck-Boost	Series/Parallel	TRIAC, TE	✓	✓	6 TSOT, 8 SOIC	0.75
<b>TPS92310</b>	13	36	Configurable	150	AC/DC	✓	✓	Flyback/Buck	Series/Parallel	TRIAC, TE	✓	✓	10 MSOP	0.55
<b>TPS92311</b>	13	36	Configurable	150	AC/DC	✓	✓	Flyback/Buck	Series/Parallel	TRIAC, TE	✓	✓	16 SOIC	0.72
<b>TPS92314/A</b>	13	35	Configurable	150	AC/DC	✓	✓	Flyback/Buck	Series/Parallel	TRIAC, TE	✓	✓	8 SOIC	0.55
<b>TPS92070</b>	9	21.5	Configurable	146	AC/DC	✓	✓	Flyback	Series/Parallel	TRIAC	✓	✓	16 TSSOP	0.95
<b>LM3444</b>	8	13	Configurable	1000	AC/DC	✓	✓	Flyback/Buck	Series/Parallel	No	✓	✓	10 MSOP	0.60
<b>LM3445</b>	8	12	Configurable	1000	AC/DC	✓	✓	Flyback/Buck	Series/Parallel	TRIAC, TE	✓	✓	10 MSOP, 14 SOIC	0.72
<b>LM3447</b>	7.5	17.5	Configurable	70	—	✓	✓	Flyback	Series/Parallel	TRIAC, TE	✓	✓	14 TSSOP	0.85
<b>LM3448</b>	8	12	Configurable	1000	AC/DC	✓	✓	Flyback/Buck	Series/Parallel	TRIAC, TE	✓	✓	16 SOIC	1.04
<b>LM3450/A</b>	8.5	20	Configurable	120	AC/DC	✓	✓	Flyback	Series/Parallel	TRIAC, TE	✓	✓	16 TSSOP	1.76
<b>UCC28810</b>	15.4	18	Configurable	140	AC/DC	✓	✓	Flyback/Boost	Series/Parallel	TRIAC	✓	✓	8 SOIC	0.32
<b>UCC28811</b>	12	18	Configurable	140	AC/DC	✓	✓	Flyback/Boost	Series/Parallel	PWM/Analog	✓	✓	8 SOIC	0.32

\*Suggested resale price in U.S. dollars in quantities of 1,000.

New devices are listed in bold red.

# LED Lighting

## General Illumination

### Selection Guide (Continued)

Device	Max LED Current (mA)	Input Voltage Range (V)	Maximum Output Voltage (V)	Maximum Number of LEDs in Series	Switching Frequency (MHz)	Topology	Features	Packaging	Price*
<b>DC/DC High-Brightness LED Drivers</b>									
LM3464/A	1000+	12 to 80/ 12 to 95	80/95	25	Up to 1 MHz	Boost	Dynamic headroom control, 4 output channels	28 eTSSOP	3.42/3.93
LM3466	1500	6 to 70	70	20	—	Linear	LED string current equalization	8 ePSOP	0.90
LM3414/HV	1000	4.5 to 42/ 4.5 to 65	80/95	16	Up to 1 MHz	Buck	Thermal foldback , analog and PWM dimming	8 ePSOP/LLP	1.10/1.25
LM3492	200	4.5 to 65	65	17	Up to 1 MHz	Boost	Dynamic headroom control, 2 output channels,1000:1 dimming contrast ratio	20 eTSSOP	1.27
<b>LM3492HC</b>	250	4.5 to 65	65	17	Up to 1 MHz	Boost	Dynamic headroom control, 2 output channels,1000:1 dimming contrast ratio	20 eTSSOP	1.50
LM3431	150 per string	5.0 to 36	40+	30	1	Analog, PWM	3-string output	28 TSSOP/LLP	1.67
LM3402/02HV	500	6.0 to 42/ 6.0 to 75	40/70	12/20	Adjustable up to 1 MHz	Buck	Fast PWM dimming, no control loop compensation, supports ceramic capacitor and capacitor-less outputs	8 MSOP/PSOP	0.91/1.17
LM3404/04HV	1000	6.0 to 42/ 6.0 to 75	40/70	12/20	Adjustable up to 1 MHz	Buck	Fast PWM dimming, no control loop compensation, supports ceramic capacitor and capacitor-less outputs	8 SOIC/PSOP	1.17/1.39
LM3410	1000	2.7 to 5.5	24	6	525 kHz/ 1.6 MHz	Boost, SEPIC	PWM dimming, small footprint, low external component count	5 SOT23, 6 LLP	1.10
LM3406/06HV	1500	6.0 to 42/ 6.0 to 75	40/70	12/20	Adjustable to 1 MHz	Buck	Fast PWM dimming. no control loop compensation, supports ceramic capacitor and capacitor-less outputs	14 eTSSOP	1.41/1.50
LM3421/23/29	>2000	4.5 to 75	75	20	Adjustable to 2 MHz	Boost, SEPIC, Buck	Fast PWM dimming, LED ready, broken open check overvoltage protection, FLT, cycle-by-cycle current limit	16/20/14 eTSSOP	1.42/1.52/ 1.22
LM3433/34	6000+	-9.0 to -14	-6	1	Adjustable up to 1 MHz	Buck	Drives common-anode LEDs, analog and fast PWM dimming	24 LLP	2.18/2.38
LM3409/HV	5000	6.0 to 42/ 6.0 to 75	42/75	13/23	1 MHz	Buck	PWM and analog dimming, high-side current sense, 100% duty cycle achievable	10 eMSOP	1.20/1.30
LM3424	3000+	3.5 to 75	75	18	Adjustable to 2 MHz	Boost, SEPIC	Temperature foldback , synchronizable 50-kHz max PWM dimming	20 eTSSOP	1.57
TPS40211	3000+	4.5 to 52	50	15	Up to 1 MHz	Boost, SEPIC, Flyback	Programmable soft start, overcurrent protection with auto retry, programmable oscillator frequency	10 MSOP, 10 SON	0.99
<b>TPS92510</b>	1500	3.5 to 60	57	16	Adjustable up to 2.5 MHz	Buck	Thermal foldback , analog and PWM dimming, frequency sync	10 eMSOP	1.50
<b>TPS92550</b>	450	4.5 to 36	34	10	400 kHz	Buck	Integrated micro-module	7 TO-PMOD	5.00
<b>TPS92551</b>	450	4.5 to 60	57	16	800 kHz	Buck	Integrated micro-module	7 TO-PMOD	5.50
<b>TPS92690</b>	>2000	4.5 to 75	75	20	Adjustable to 2 MHz	Boost, SEPIC, Buck, Cuk	Fast PWM dimming, LED ready, broken open check overvoltage protection, FLT, cycle-by-cycle current limit	16 eTSSOP	1.45
<b>TPS92660</b>	>2000	10 to 80	75	21	Adjustable up to 1 MHz	Buck + Linear	Two-string LED driver with I <sup>2</sup> C/EEPROM current trim for high CRI lighting	20 eTSSOP	1.50
<b>TPS92560</b>	>1000	6.5 to 42	42	12	Adjustable up to 1.5 MHz	Buck, SEPIC	Integrated active low-side input rectifiers	10 eMSOP	0.72

\*Suggested resale price in U.S. dollars in quantities of 1,000.

New devices are listed in **bold red**.

# Display Power

## LCD/OLED Display Bias Solutions

### Fully I<sup>2</sup>C Programmable 6-Channel LCD Bias IC with Gate-Pulse Modulation for All TV Sizes

#### TPS65177

The TPS65177 provides all supply rails needed by a gate in panel (GIP) or non-GIP TFT-LCD panel. All output voltages are I<sup>2</sup>C programmable.

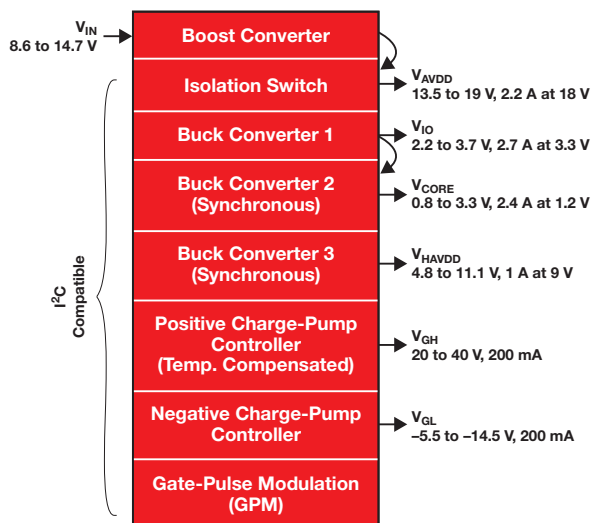

#### Key Features

- Gate-pulse modulation (GPM)
- Temperature compensation for  $V_{GH}$
- 40-pin 6 x 6-mm QFN package
- I<sup>2</sup>C-compatible interface
- Input voltage: 8.6 to 14.7 V
- Integrated  $V_{AVDD}$  isolation switch
- 6-bit boost converter  $V_{AVDD}$ : 13.5 to 19.8 V
- 3-bit programmable switch current limit of up to 4.25 A
- 4-bit programmable high-voltage-stress mode
- 1-bit programmable soft start
- 6-bit synchronous buck  $V_{HAVDD}$ : 4.8 to 11.1 V
- 1.7-A switch current limit
- 4-bit buck converter  $V_{IO}$ : 2.2 to 3.7 V

#### Applications

- GIP LCD TVs
- Non-GIP LCD TVs

Get more information at: [www.ti.com/product/TPS65177](http://www.ti.com/product/TPS65177)

### Dual-Output Power Supply for AMOLED Displays

#### TPS65631

The TPS65631 is designed to drive AMOLED displays requiring positive and negative supply rails. It integrates a boost converter for  $V_{POS}$ , an inverting buck-boost converter for  $V_{NEG}$  suitable for battery-operated products. The digital control pin (CTRL) allows the negative output voltage to be programmed in digital steps. The TPS65631 uses a novel technology enabling excellent line-transient regulation and efficiency.

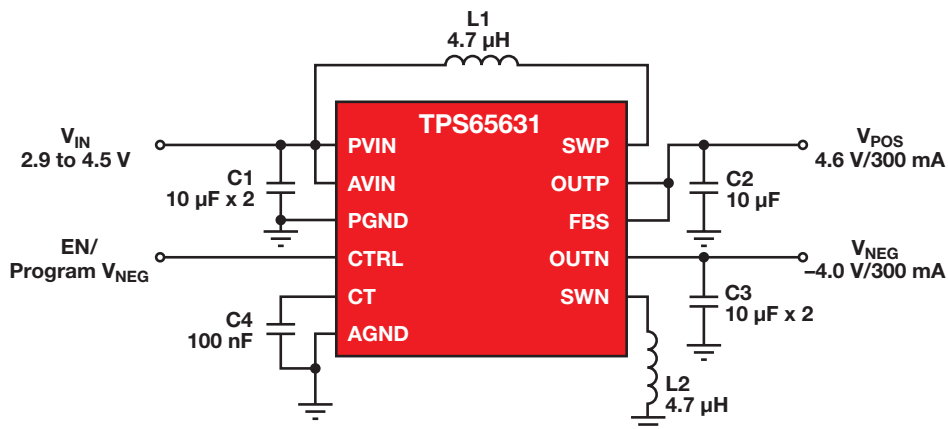

#### Key Features

- 0.5% accuracy  $V_{POS}$
- Excellent line-transient regulation
- 300-mA output current
- Short-circuit protection covering start-up, operation and overload
- Best-in-class efficiency
- 2.9- to 4.5-V input-voltage range
- Fixed 4.6-V  $V_{POS}$  output voltage
- Digitally programmable  $V_{NEG}$  of -1.4 to -4.4 V (default -4 V)
- Thermal shutdown
- 3 x 3-mm, 12-pin QFN package

#### Applications

- Active matrix OLED (AMOLED) displays below 5.5"

Get more information at: [www.ti.com/product/TPS65631](http://www.ti.com/product/TPS65631)

# Display Power

## LCD/OLED Display Bias Solutions

### Selection Guide

Device	V <sub>IN</sub> (V)	Boost I <sub>Limit</sub> (min) (A)	Buck I <sub>Limit</sub> (min) (A)	Features <sup>1</sup>							Price*
				Isolation Switch	V <sub>GH</sub>	V <sub>GL</sub>	GVS	V <sub>Com</sub>	HVS	Other	
<b>Solutions for Large LCDs (TVs)</b>											
TPS65160/A	12	2.8	2	External	Driver	Driver	—	—	—		2.14
TPS65161	12	2.8	2.3	External	Driver	Driver	—	—	—		2.78
TPS65161A	12	3.7	2.3	External	Driver	Driver	—	—	—		2.78
TPS65161B	12	3.7	2.5	External	Driver	Driver	—	—	—		2.78
TPS65162	12	2.8	2.8	Integrated	Driver	Driver	Yes	2 op amps	—		2.45
TPS65163	12	2.8	1.5	External	Controller	Controller	In level shifter	—	—	9-ch level shifter, LCD discharge, reset generator	2.32
TPS65168	12	3.5	2.8	Integrated	Controller	Controller	—	—	—	I <sup>2</sup> C programmable, 2 buck, temp. compensation, reset	2.10
TPS65170	12	2.8	1.5	External	Controller	Controller	—	—	—	Reset	1.40
TPS65176	12	3.5	2.5	External	Controller	Controller	—	—	—	Max AVDD 18.5 V, Vlogic 3.3 V	1.00
TPS65178	12	3.5	2.6	Integrated	Controller	Controller	—	—	—	Integrated 6-ch gamma buffer, I <sup>2</sup> C, Vcom, bucks for HVDD, VCC, VCORE, VEPI, boost for VDD	1.90
TPS65177	12	4.25	3	Integrated	Controller	Controller	Yes	—	—	Temp compensation, I <sup>2</sup> C, 1 boost, 3 bucks	1.90

Device	V <sub>IN</sub> (V)	Boost I <sub>Limit</sub> (min) (A)	Features <sup>1</sup>								Price*
			Oversvoltage Protection	Isolation Switch	V <sub>Logic</sub>	V <sub>GH</sub>	V <sub>GL</sub>	GVS	V <sub>Com</sub>	Other	
<b>Solutions for Medium and Small LCDs (Monitors and Notebooks)</b>											
TPS61085	5	2	Yes	—	—	External	External	—	—		0.95
TPS61087	5	3.2	Yes	—	—	External	External	—	—		1.60
TPS65100	5	1.6	Yes	—	LDO controller	Integrated	Driver	—	1 buffer		1.87
TPS65105	5	0.96	Yes	—	LDO controller	Integrated	Driver	—	1 buffer		1.87
TPS65140	5	1.6	Yes	—	LDO controller	Integrated	Driver	—	—		1.71
TPS65142	5	1.8	Yes	—	LDO	Driver	External	Yes	1 buffer	Integrated 6-ch WLED backlight driver, with integrated MOSFET	1.35
TPS65145	5	0.96	Yes	—	LDO controller	Integrated	Driver	—	—		1.71
TPS65148	2.5 to 6	4	Yes	External	LDO	External	External	Yes	1 buffer	LDO for gamma, reset (/XA0), LCD discharge	2.10
TPS65149	3 to 6	4.0	Yes	External	—	Controller	Controller	—	Programmable, no buffer	Level shifters, reset	1.90
TPS65150	5	2	Yes	External	—	Driver	Driver	Yes	1 buffer		1.92
TPS65165	5	4.4	Yes	—	—	Integrated	Driver	Yes	2 op amps, 1 buffer		1.80

<sup>1</sup>V<sub>GH</sub> = Positive LCD rail voltage, V<sub>GL</sub> = Negative LCD rail voltage, GVS = Gate-voltage shaping for V<sub>GH</sub>, V<sub>Com</sub> = LCD V<sub>Com</sub> voltage source, and HVS = High-voltage stress-test control.

\*Suggested resale price in U.S. dollars in quantities of 1,000.

Device	Description	Number of Channels			V <sub>GH1</sub> (max) (V)	V <sub>GH2</sub> (max) (V)	V <sub>GL</sub> (max) (V)	V <sub>Com</sub>	GVS/GPM	Charge Sharing	Other	Package	Price*
		Clock	Discharge	Additional									
<b>LCD Support IC Solutions (Scan Drivers/Level Shifters)</b>													
TPS65192	10-channel level shifter for LCD displays w/GPM	7	1	2	38	38	-15	—	Yes	—	LCD discharge	QFN-28	1.40
TPS65194	13-channel level shifter for LCD displays w/V <sub>Com</sub> op amp	6	1	6	38	38	-15	Op amp 200 mA	—	—	State machine	QFN-24	0.80
TPS65193	5-channel level shifter for LCD displays (dual channel scan driver)	5	—	—	35	—	-28	—	—	Yes		QFN-24	0.80
TPS65196	15-channel level shifter for LCD displays	8	1	6	38	38	-23	—	Yes	—	Soft-start	QFN-28	0.80
TPS65198	13-channel level shifter for LCD displays w/V <sub>Com</sub> op amp	6	1	6	38	38	-23	Op amp 200 mA	Yes	—	4x4 package	QFN-24	1.00
TPS65197	8-channel level shifter supporting different charge-sharing methods and panel discharge	6	2	—	45	—	-20	—	—	Selectable: Disable, Method 1, Method 2	4x4 package	QFN-28	1.00

\*Suggested resale price in U.S. dollars in quantities of 1,000.

# Display Power

## LCD/OLED Display Bias Solutions

### Selection Guide (Continued)

Device <sup>1</sup>	V <sub>IN</sub> (V)	LDO 1	LDO 2	Charge Pump 1	Charge Pump 2	Application	Communication Interface	V <sub>Com</sub> Adjust	Active Discharge	P2P with TPS65181/2	Package	Price*
<b>Solutions for E-Readers</b>												
TPS65185	3 to 6	15 V, 120 mA	-15 V, 120 mA	22 V, 10 mA	-20 V, 12 mA	Power supply for Active Matrix E Ink <sup>®</sup> Vizplex <sup>®</sup> panels	I <sup>2</sup> C	User programmable (internal)	Yes	No	QFN-48 (0.5 mm 7x7 or 0.4 mm 6x6)	1.75
TPS65186	3 to 6	15 V, 120 mA	-15 V, 120 mA	22 V, 10 mA	-20 V, 12 mA	Power Supply for Active Matrix E Ink Vizplex panels	I <sup>2</sup> C	User programmable (internal)	No	Yes	QFN-48 (0.5 mm 7x7)	1.75

<sup>1</sup>See datasheets for more specifications.

\*Suggested resale price in U.S. dollars in quantities of 1,000.

Device	Description	Features	V <sub>IN</sub>		Frequency	AV <sub>DD</sub> I <sub>Limit</sub> (min) (mA)	AV <sub>DD</sub> (max) (V)	Isolation Switch	V <sub>Logic1</sub> I <sub>Limit</sub> (min) (A)	V <sub>Logic1</sub> (min) (V)	V <sub>GH</sub> (I <sub>GH</sub> )	V <sub>GL</sub> (I <sub>GL</sub> )	Other	Package	Price*
			(min) (V)	(max) (V)											
<b>LCD SFF/MFF — IPS and OLED Solutions (&lt;5 V)</b>															
TPS65120	4-ch single inductor multiple outputs (SIMO) bias IC w/ fixed 3.3-V V <sub>Logic</sub>	Small form factor	2.5	5.5	4 MHz	7.5/25	5.6	Internal	LDO controller	Fixed 3.3	Integrated 20 V max. (6 mA)	Inverter -18 V max. (6 mA)	—	QFN-16	0.95
TPS65121	4-ch single inductor multiple outputs (SIMO) bias IC w/ fixed 1.8-V V <sub>Logic</sub>	Small form factor	2.5	5.5	4 MHz	7.5/25	5.6	Internal	LDO controller	Fixed 1.8	Integrated 20 V max. (6 mA)	Inverter -18 V max. (6 mA)	—	QFN-16	0.95
TPS65124	3-ch single inductor multiple outputs (SIMO) bias IC w/ adjustable sequencing	Small form factor	2.5	5.5	4 MHz	7.5/25	5.6	Internal	—	—	Integrated 20 V max. (6 mA)	Inverter -18 V max. (6 mA)	Adjustable sequencing	QFN-16	0.95
TPS65130	Dual positive and negative outputs (700 mA)	OLED, CCD sensor	2.7	5.5	1.4 MHz	—	—	External	—	—	Boost 15 V max. (0.7 A I <sub>Limit</sub> )	Inverter -15 V max. (0.7 A I <sub>Limit</sub> )	—	QFN-24	1.70
TPS65131	Dual positive and negative outputs (1800 mA)	OLED, CCD sensor	2.7	5.5	1.4 MHz	—	—	External	—	—	Boost 15 V max. (1.8 A I <sub>Limit</sub> )	Inverter -15 V max. (1.8 A I <sub>Limit</sub> )	—	QFN-24	2.20
TPS65136	Single inductor multiple outputs (SIMO) for positive and negative output	AMOLED	2.3	5.5	40 kHz to 1 MHz	—	—	Internal	—	—	Boost fixed 4.6 V (80 mA)	Inverter -6 V max. (80 mA)	—	QFN-16	1.20
TPS65137	Dual positive and negative output w/digital V <sub>neg</sub> adjustment	AMOLED	2.3	5.5	1.6 MHz	—	—	Internal	—	—	Boost fixed 4.6 V (200 mA)	Inverter -5.2 V max. (200 mA)	Digital adjust for V <sub>GL</sub>	QFN-10	0.85
TPS65138	Dual positive and negative output w/digital V <sub>neg</sub> adjustment	AMOLED	2.9	4.5	1.6 MHz	—	—	Internal	—	—	Boost fixed 4.62 V (300 mA)	Inverter -2.2 down to -5.2 V max. (300 mA)	0.8% V <sub>pos</sub> accuracy	QFN-10	0.95
TPS65631	Dual-output AMOLED display power supply	AMOLED	2.9	4.5	1.7 MHz	—	—	Internal	—	—	Boost fixed 4.6 V (300 mA)	Inverter -1.4 down to -4.4 V max. (300 mA)	0.5% V <sub>pos</sub> accuracy	QFN-12	1.20
TPS65632A	Triple-output AMOLED display power supply	AMOLED	2.9	4.5	1.7 MHz	—	—	Internal	—	—	Boost fixed 4.6 V (300 mA)	Inverter -1.4 down to -4.4 V max. (300 mA)	0.5% V <sub>pos</sub> accuracy, fixed AVDD of 7.7 V	QFN-16	1.50
TPS65135	Single inductor multiple outputs (SIMO) for positive and negative output	SFF/MFF IPS panel	2.5	5.5	1 MHz	—	—	Internal	—	—	Boost up to 6 V	Inverter down to -7 V	80-mA output current, 50% current mismatch	QFN-16	1.20

\*Suggested resale price in U.S. dollars in quantities of 1,000.

### Gamma Buffers

Channels	0-V <sub>Com</sub> Channels	1-V <sub>Com</sub> Channels	2-V <sub>Com</sub> Channels
22 (+2 static)			BUF22821
18		LM8207	BUF18830, BUF20800, BUF20820
16		BUF16822	BUF16821
14			BUF16820
12	BUF12800, BUF12840		
10		BUF11702/4/5	
8		BUF08821, BUF08832, BUF08630	
7		BUF08800	
6	BUF06703, BUF06704	BUF07702/3/4	
4	BUF04701	BUF05703, BUF05704	
0		BUF01900, BUF01901	



# Display Power

## LED Drivers—Backlighting

### Design Factors

**Dot Correction** — Creates uniform LED brightness. Gives the ability to dynamically control the output current.

**Grayscale** — Provides an enhanced color spectrum per LED equivalent with the number of grayscale steps available.

**Output Voltage Monitor** — Monitors voltages at constant current output terminals to detect LED failure and short circuit.

**LED Open Detection** — Indicates a broken or disconnected LED at an output terminal.

**Thermal Error Flag** — Indicates an overtemperature condition.

**Watchdog Timer** — Turns output off when scan signal is stopped.

**Thermal Shutdown** — Turns output off when junction temperature exceeds its limit.

### LED Drivers Function Guide

	20	30	40	60	
Multichannel		<b>TPS61150/1</b> ~14 WLEDs, 2 x 35 mA, $V_{OUT(max)} = 27\text{ V}$ , $V_{IN} = 2.5\text{ to }6.0\text{ V}$	<b>TPS61185</b> ~80 WLEDs, 8 x 25 mA, $V_{OUT(max)} = 38\text{ V}$ , $V_{IN} = 4.2\text{ to }24\text{ V}$	<b>LP8552</b> 60–66 WLEDs, 6 x 55 mA, $V_{OUT(max)} = 40\text{ V}$ , $V_{IN} = 2.7/4.5\text{ to }22\text{ V}$	<b>TPS61196</b> 120 LEDs, 6 x 200 mA*, $V_{OUT(max)} = 120\text{ V}$ , $V_{IN} = 8\text{ to }30\text{ V}$ <small>*Continuous current (400-mA pulse)</small>
			<b>TPS61183</b> ~80 WLEDs, 6 x 30 mA, $V_{OUT(max)} = 40\text{ V}$ , $V_{IN} = 4.5\text{ to }24\text{ V}$	<b>TPS61176</b> 60 LEDs, 6 x 30 mA, $V_{OUT(max)} = 40\text{ V}$ , $V_{IN} = 2.7\text{ to }6.5\text{ V}$	<b>TPS61199</b> ~120 WLEDs, 8 x 80 mA, $V_{OUT(max)} = 60\text{ V}$ , $V_{IN} = 4.5\text{ to }21\text{ V}$
			<b>LM3532</b> 30 LEDs, 3 x 30 mA, $V_{OUT(max)} = 40\text{ V}$ , $V_{IN} = 2.7\text{ to }5.5\text{ V}$	<b>LP8553</b> 40–44 WLEDs, 4 x 55 mA, $V_{OUT(max)} = 40\text{ V}$ , $V_{IN} = 2.7/4.5\text{ to }22\text{ V}$	<b>TPS61195</b> ~96 WLEDs, 8 x 30 mA, $V_{OUT(max)} = 45\text{ V}$ , $V_{IN} = 4.5\text{ to }21\text{ V}$
			<b>LM3630</b> 20 LEDs, 2 x 28 mA, $V_{OUT(max)} = 40\text{ V}$ , $V_{IN} = 2.3\text{ to }5.5\text{ V}$	<b>LP8545</b> 40–44 WLEDs, 4 x 55 mA, $V_{OUT(max)} = 40\text{ V}$ , $V_{IN} = 2.7/4.5\text{ to }22\text{ V}$ <small>*55 V with external FET</small>	<b>LP8856</b> 60 LEDs, 6 x 30 mA, $V_{OUT(max)} = 40\text{ V}$ , $V_{IN} = 2.7\text{ to }6.5\text{ V}$
			<b>LM3533</b> 20 LEDs, 2 x 30 mA, $V_{OUT(max)} = 40\text{ V}$ , $V_{IN} = 2.7\text{ to }5.5\text{ V}$		
	Single Channel	<b>TPS61166</b> ~3s3p WLEDs, 300 mA, $V_{OUT(max)} = 18\text{ V}$ , $V_{IN} = 2.5\text{ to }10\text{ V}$	<b>TPS61062</b> ~5 WLEDs, 25 mA, $V_{OUT(max)} = 23\text{ V}$ , $V_{IN} = 2.7\text{ to }6.0\text{ V}$	<b>TPS61500</b> ~12 WLEDs, 3.8 A, $V_{OUT(max)} = 38\text{ V}$ , $V_{IN} = 2.9\text{ to }18\text{ V}$	<b>TPS61165</b> ~27 WLEDs, 3s9p, 350 mA, $V_{OUT(max)} = 38\text{ V}$ , $V_{IN} = 3.0\text{ to }18\text{ V}$
		<b>TPS61060</b> ~3 WLEDs, 40 mA, $V_{OUT(max)} = 14\text{ V}$ , $V_{IN} = 2.7\text{ to }6.0\text{ V}$	<b>TPS61160</b> ~6 WLEDs, 20 mA, $V_{OUT(max)} = 26\text{ V}$ , $V_{IN} = 2.7\text{ to }18\text{ V}$	<b>LM3530</b> 10 LEDs, 1 x 30 mA, $V_{OUT(max)} = 40\text{ V}$ , $V_{IN} = 2.7\text{ to }5.5\text{ V}$	<b>TPS61161</b> ~10 WLEDs, 20 mA, $V_{OUT(max)} = 38\text{ V}$ , $V_{IN} = 2.7\text{ to }18\text{ V}$
		<b>TPS61061</b> ~4 WLEDs, 30 mA, $V_{OUT(max)} = 18\text{ V}$ , $V_{IN} = 2.7\text{ to }6.0\text{ V}$			
Overvoltage Protection, $V_{OUT}$ Maximum (V)					

# Display Power

## LED Drivers—Backlighting

### High-Efficiency LED Backlight Driver for Tablets and Notebooks LP8552

**PREVIEW**

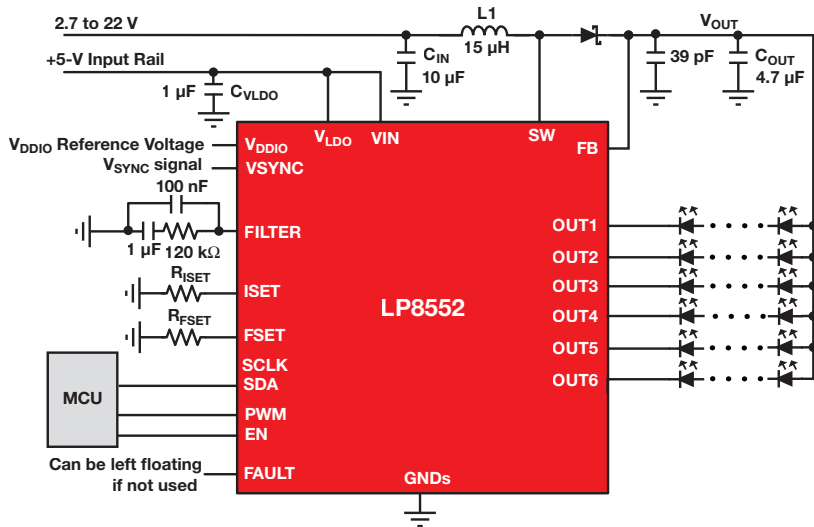

#### Key Features

- Advanced slope control eliminates human eye glitch response of step or linear ramp
- Dithering during transition enables smooth effect
- High-voltage DC/DC boost converter with integrated FET with four switching frequency options: 156/312/625/1250 kHz
- 2.7- to 22-V input-voltage range to support 1x...5x cell Li-Ion batteries
- Programmable PWM resolution
  - True 8- to 13-bit (steady state)
  - Additional 1 to 3 bits using dithering during brightness changes
- I<sup>2</sup>C and PWM brightness control

#### Applications

- Notebook and netbook LCD display LED backlight
- LED lighting

### 6-Channel, High-Efficiency WLED Drivers Supporting Single-Cell-Battery Inputs

#### LP8556, TPS61176

The LP8556 and TPS61176 provide highly integrated solutions for tablet PC backlighting and support an input voltage as low as 2.7 V (suitable for a single-cell battery). Both devices support 6 channels of LEDs and mixed-mode dimming for high efficiency.

#### Key Features (LP8556/TPS61176)

- Maximum LED current per channel: 50 mA/30 mA
- Dimming methods: PWM, adaptive, pure analog/mixed-mode

- Programmability: EPROM/resistor
- Package: 20 SMD/16 QFN
- Phase shift (LP8556)

#### Applications

- Tablet backlight powered by single-cell battery
- Backlight for small and medium form-factor LCD display with input from single-cell or multicell battery

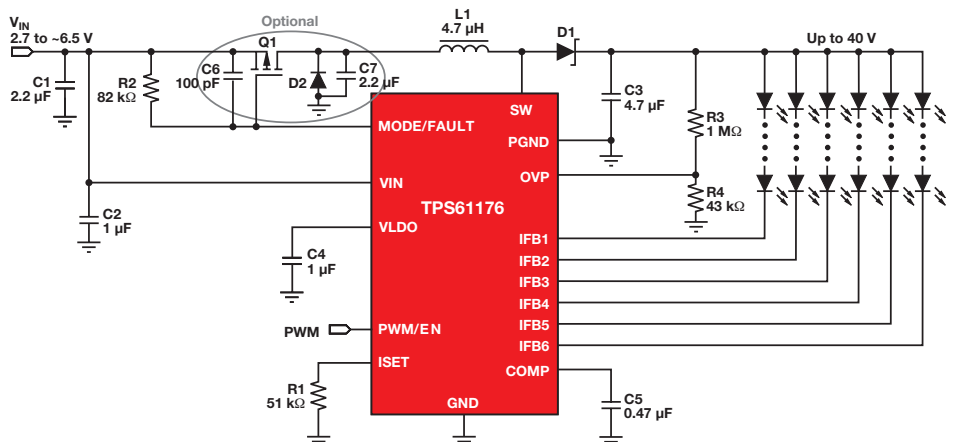
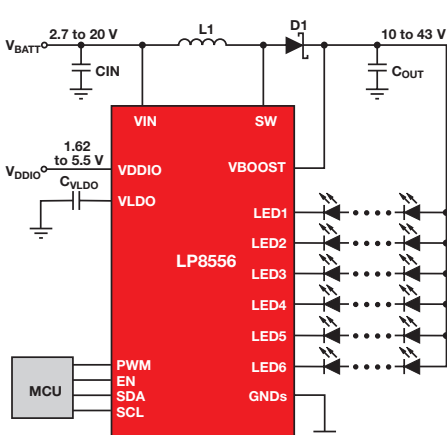

Get more information at: [www.ti.com/product/LP8556](http://www.ti.com/product/LP8556) or [TPS61176](http://www.ti.com/product/TPS61176)

# Display Power

## LED Drivers—Backlighting

### Selection Guide

Device	V <sub>IN</sub> (V)	Synchronous	Type	Number of LEDs <sup>1</sup>	OLED Capable	LED Configuration	Switch Current Limit (typ) (mA)	Current Regulation	Overvoltage Protection (min) (V)	Output Capacitor	Load-Disconnect During Shutdown	Dimming <sup>2</sup>	Peak Efficiency <sup>3</sup> (%)	Quiescent Current (typ) (mA)	Shutdown Current (typ) (µA)	Package(s)	Price*
<b>WLED Drivers</b>																	
<b>TPS61041</b>	1.8 to 6.0		Inductive	4		Series	250		No	1 µF		Yes	85	0.028	0.1	SOT-23	0.65
<b>TPS61040</b>	1.8 to 6.0		Inductive	6		Series	400		No	1 µF		Yes	86	0.028	0.1	SOT-23	0.65
<b>TPS61043</b>	1.8 to 6.0		Inductive	4		Series	400	✓	17	100 nF	✓	Yes	85	0.038	0.1	QFN-8	0.71
<b>TPS61042</b>	1.8 to 6.0		Inductive	6		Series	500	✓	28	100 nF	✓	Yes	85	0.038	0.1	QFN-8	0.75
<b>TPS61045</b>	1.8 to 6.0		Inductive	6	✓	Series	500	✓	28	100 nF	✓	Yes	85	0.038	0.1	QFN-8	0.90
<b>TPS61140</b>	2.5 to 6.0	✓	Inductive	4 + 1 OLED	✓	2 Series	2 x 550	✓	28	—		1-pin	82	2	1.5	QFN-10	1.00
<b>TPS61150A</b>	2.5 to 6.0	✓	Inductive	Up to 2 x 6		2 Series	2 x 550	✓	28	—		1-pin	83	2	1.9	QFN-10	1.00
<b>TPS61166</b>	2.5 to 6.0	✓	Inductive	5		Series	1100 <sup>4</sup>	✓	19	4.7 µF	✓	Yes		1.5	1	QFN-10	1.35
<b>TPS61160</b>	2.7 to 18		Inductive	6		Series	700	✓	26	1 µF		1-pin	90	1.8	1	QFN-6	0.72
<b>TPS61160A</b>	2.7 to 18		Inductive	6		Series	700	✓	26	1 µF		Yes	90	1.8	1	QFN-6	0.72
<b>TPS61161</b>	2.7 to 18		Inductive	10		Series	700	✓	38	1 µF		1-pin	90	1.8	1	QFN-6	0.76
<b>TPS61161A</b>	2.7 to 18		Inductive	10		Series	700	✓	38	1 µF		Yes	90	1.8	1	QFN-6	0.76
<b>TPS61165</b>	3.0 to 18		Inductive	10 to 40		Series	1200	✓	38	1 µF		1-pin	90	2.3	1	QFN-6	1.10
<b>TPS61060</b>	2.7 to 6.0	✓	Inductive	3		Series	400	✓	14	220 nF		Yes	83	—	1	QFN-8/WCSP-8	0.85
<b>TPS61061</b>	2.7 to 6.0	✓	Inductive	4		Series	400	✓	18	220 nF		Yes	82	—	1	QFN-8/WCSP-8	0.90
<b>TPS61062</b>	2.7 to 6.0	✓	Inductive	5		Series	400	✓	22	220 nF		Yes	81	—	1	QFN-8/WCSP-8	0.97
<b>REG71050</b>	3.2 to 5.5		Charge pump	3		Parallel	—		—	2.2 µF		No	92	0.065	0.01	SOT-23	0.55
<b>TPS60230/1</b>	2.7 to 6.5		Charge pump	5, 3		Parallel	—	✓	—	1 µF		Yes	85	0.200	0.1	QFN-16	0.48
<b>TPS60250/5</b>	2.7 to 6.0		Charge pump	7		Parallel	—	✓	—	4.7 µF		I <sup>2</sup> C	—	6.7	1.3	QFN-16	0.85
<b>TPS60251</b>	2.7 to 6.0		Charge pump	7 + Aux		Parallel	—	✓	—	4.7 µF		I <sup>2</sup> C	—	6.7	1.3	QFN-24	0.85
<b>TPS75103/5</b>	2.7 to 5.5		LDO	2 or 4		Parallel	—	✓	—	—		Yes	—	0.18	0.1	WCSP-9	0.65
<b>TCA6507</b>	1.65 to 3.6		Parallel	7		Parallel	—	—	—	—		—	—	—	—	WCSP-12/QFN-12	0.80
<b>TPS61183/87</b>	4.5 to 24		Inductive	10 x 6		6 Channels	2000	✓	38	10 µF		Yes	95	4	11	QFN-20	1.85
<b>TPS61185</b>	4.2 to 24		Inductive	10 x 8		8 Channels	2000	✓	38	10 µF		Yes	94	<3	<10	QFN-24	1.80
<b>TPS61195</b>	4.5 to 21		Inductive	8 x 10		10 Channels	3500	✓	50	10 µF		Yes	95	<3	<10	QFN-28	1.95
<b>TPS61176</b>	2.7 to 6.5		Inductive	6 x 10/11		6 Channels	1000	✓	38	4.7 µF		Mixed-Mode	90	<3	<4	QFN-16	1.10
<b>TPS61199<sup>5</sup></b>	8 to 30		Inductive	15 x 8		8 Channels	5000	✓	30	3 x 33 µF		Yes	93	<1.5	<10	SOP-20/HTSSOP-20	1.85
<b>LP8543</b>	4.5 to 22		Inductive	7 x 10		7P10S	2500	±0.5	V <sub>BOOST</sub> + 1.6 V	4.7, 10 µF		PWM, I <sup>2</sup> C, ALS	92	<3.5, Boost ON	—	QFN-24	2.30
<b>TPS61196</b>	8 to 30		Inductive	20 x 6		6 Channels	—	✓	38	100 µF		PWM	96	<1.5	<15	HTSSOP-28	1.85
<b>LP8545</b>	4.5 to 22		Inductive	6 x 10		6P10S	2500	±0.5	V <sub>BOOST</sub> + 1.6 V	4.7, 10 µF		PWM, I <sup>2</sup> C	95	<4, Boost ON	—	QFN-24	2.30
<b>LP8550</b>	4.5 to 22		Inductive	6 x 10		6P10S	2500	±0.5	V <sub>BOOST</sub> + 1.6 V	4.7, 10 µF		PWM, I <sup>2</sup> C	95	<3, Boost ON	—	micro SMD-25	1.75
<b>LP8552</b>	4.5 to 22		Inductive	6 x 10		6P10S	2500	±0.5	V <sub>BOOST</sub> + 1.6 V	4.7, 10 µF		PWM, I <sup>2</sup> C	95	<3, Boost ON	—	micro SMD-25	1.75
<b>LP8553</b>	4.5 to 22		Inductive	4 x 10		4P10S	2500	±0.5	V <sub>BOOST</sub> + 1.6 V	4.7, 10 µF		PWM, I <sup>2</sup> C	95	<3, Boost ON	—	micro SMD-25	1.75
<b>LP8556</b>	2.7 to 20		Inductive	6 x 10		6P10S	2600	✓	V <sub>BOOST</sub> + 1.6 V	4.7, 10 µF		PWM, I <sup>2</sup> C	95	2.2	—	micro SMD-25/ QFN-24	0.75
<b>LM3528</b>	2.5 to 5.5		Inductive	12	✓	2P6S	770	✓	19.25	1 µF	✓	I <sup>2</sup> C	85	0.25	1.8	WCSP-12	1.10
<b>LM3530</b>	2.7 to 5.5		Inductive	11		10 Series	839	✓	40	1 µF	✓	I <sup>2</sup> C	88	1.35	1	WCSP-12	1.60
<b>LM3532</b>	2.7 to 5.5		Inductive	30		3P10S	1000	✓	40	1 µF	✓	I <sup>2</sup> C	87	1.35	1	WCSP-16	1.60
<b>LM3533</b>	2.7 to 5.5		Inductive	22		2P10S	1000	✓	40	1 µF	✓	I <sup>2</sup> C	87	—	—	WCSP-20	1.80
<b>LM3535</b>	2.7 to 5.5		Charge pump	8		8P	—	✓	—	1 µF	✓	I <sup>2</sup> C	92	1.1	1.7	WCSP-20	1.70
<b>LM3537</b>	2.7 to 5.5		Charge pump	8		8P	—	✓	—	1 µF	✓	I <sup>2</sup> C	92	1.1	0.2	WCSP-30	1.90
<b>LM3538</b>	2.7 to 5.5		Charge pump	8		8P	—	✓	—	1 µF	✓	I <sup>2</sup> C	92	1.1	0.2	WCSP-30	1.70
<b>LM3630</b>	2.7 to 5.5		Inductive	20		2P10S	1200	✓	40	1 µF	✓	I <sup>2</sup> C	90	—	1.8	WCSP-12	0.40

<sup>1</sup>More LEDs can be driven in parallel string configuration.

<sup>2</sup>May be via ENABLE pin, CONTROL pin or analog feedback network.

<sup>3</sup>Depends on LED current, input voltage, number of LEDs, ILED pin.

<sup>4</sup>Output current is limited to 300 mA.

<sup>5</sup>External FET needed.

\*Suggested resale price in U.S. dollars in quantities of 1,000.

New devices are listed in bold red. Preview devices are listed in bold teal.

# Display Power

## LED Drivers—Backlighting

### Selection Guide (Continued)

Device	V <sub>IN</sub> (V)	Synchronous	Type	Number of LEDs <sup>1</sup>	OLED Capable	LED Configuration	Switch Current Limit (typ) (mA)	Current Regulation	Overvoltage Protection (min) (V)	Output Capacitor	Load-Disconnect During Shutdown	Dimming <sup>2</sup>	Peak Efficiency <sup>3</sup> (%)	Quiescent Current (typ) (mA)	Shutdown Current (typ) (μA)	Package(s)	Price*
<b>WLED Drivers (Continued)</b>																	
LM2756	2.7 to 5.5		Charge pump	8		8P	—	✓	—	1 μF	✓	I <sup>2</sup> C	92	2.1	3.7	WCSP-20	1.50
LP5521	2.7 to 5.6		Charge pump	3		3P	—	✓	—	1 μF	✓	I <sup>2</sup> C	—	—	—	WCSP-20	0.85
LP5522	2.7 to 5.7		Charge pump	1		—	—	✓	—	—	✓	1 Pin	—	—	—	WCSP-06	0.45
LP5523	2.7 to 5.8		Charge pump	9		9P	—	✓	—	1 μF	✓	I <sup>2</sup> C	—	—	—	WCSP-25	0.90
LP5524	2.7 to 5.9		Charge pump	4		4P	—	✓	—	—	✓	—	—	—	—	WCSP-09	0.66
LM8502	2.7 to 5.10	✓	Inductive	10		10P	—	✓	—	10 μF	✓	I <sup>2</sup> C	—	—	—	WCSP-30	1.80

<sup>1</sup>More LEDs can be driven in parallel string configuration.

<sup>2</sup>May be via ENABLE pin, CONTROL pin or analog feedback network.

<sup>3</sup>Depends on LED current, input voltage, number of LEDs, ILED pin.

<sup>4</sup>Output current is limited to 300 mA.

<sup>5</sup>External FET needed.

\*Suggested resale price in U.S. dollars in quantities of 1,000.

New devices are listed in bold red. Preview devices are listed in bold teal.

Device	No. of Chan.	V <sub>IN</sub> Min (V)	V <sub>IN</sub> Max (V)	Output Current I <sub>LED</sub> (mA)	Channel-to-Channel Accuracy (%)	Dev.-to-Dev. Accuracy (%)	Short Detection	Open Detection	Overtemperature Detection	Comments	Price*
<b>LED Drivers</b>											
TLC5960	8	10	28	350 <sup>1</sup>	0.3	±1	✓	✓	✓	4 iHVM™ outputs, 4 PWM controls, external FET	1.30

<sup>1</sup>TLC5960 output current is limited by external FET.

\*Suggested resale price in U.S. dollars in quantities of 1,000.

Device	Typical Power Level	Topology	Maximum Practical Frequency (kHz)	Start-Up Current (μA)	Operating Current (mA)	Supply Voltage (V)	UVLO: On/Off (V)	Max Duty Cycle (%)	Soft Start	Output Drive (Sink/Source) (A)	Package(s)	Price*
<b>LLC Controllers</b>												
UCC25600	200 W to 1 kW	Half-bridge	350	100	7.5	11.5 to 18	11.1/8.9	Variable	✓	0.4/0.8	8-SOIC	0.80
UCC25710	80 W to 500 W	Half-bridge	300	—	—	12 to 18	10/8.5	—	✓	0.4/0.8	20-SOIC	1.50

Note: UCC2xxx devices are extended temperature-range versions of the UCC3xxx devices.

\*Suggested resale price in U.S. dollars in quantities of 1,000.

# Display Power

## Camera Flash LED Drivers

### Design Factors

#### Series or Parallel LED Configuration

— Drives the driver topology. Inductive boost converters provide the necessary high voltage to a series LED string. This requires only one current regulation loop and two connection points for the LED string.

Charge pumps typically drive parallel LEDs; but unless each LED is current-regulated, each leg requires a current-set resistor.

**Current Regulation** — Avoids brightness variations in LED strings or legs that consist of LEDs with different forward voltages ( $V_f$ ).

#### Overvoltage Protection (OVP) —

Protects the inductive driver from destruction in case faulty LEDs open the LED string.

**Dimming** — LED drivers typically feature analog and/or digital dimming to adjust the LED brightness.

### Selection Guide

Device <sup>1</sup>	$V_{IN}$ (V)	Max. Number of LEDs	Privacy LED	$I_{OUT}$ (max) (mA)	Typical Switch Current (mA)	Super-Capacitor Support	Down Mode when $V_{IN} > V_{OUT}$	Control Interface	LED Temperature Monitoring	Power Save Mode	Battery Voltage-Droop Monitoring	Package(s)	Features and Differentiators	Total Solution Size (mm <sup>2</sup> )	Price*
<b>Camera Flash LED Drivers</b>															
<b>TPS61050/2</b>	2.5 to 5.5	1	✓	1200	2000			i <sup>2</sup> C				QFN-10, WCSP-12	Voltage-mode selection pin	25	1.00
<b>TPS61054/5</b>	2.5 to 5.5	1		700/500	1500/1000			Simple logic signal				QFN-10, WCSP-12		25	0.85
<b>TPS61310/1</b>	2.5 to 5.5	3	✓	1500	—		✓	i <sup>2</sup> C	✓	✓	✓	WCSP-20	HW-reset input, dual-wire camera-module interface, Power Good	25	1.00
<b>TPS61325</b>	2.5 to 5.5	3	✓	4100	—	✓	✓	i <sup>2</sup> C	✓	✓		WCSP-20	Dual-wire camera-module interface, super-capacitor balancing, flash ready output	25	1.50
<b>TPS61300/1/5</b>	2.5 to 5.5	3	✓	4100	1850	✓	✓	i <sup>2</sup> C	✓	✓		WCSP-20	Voltage-mode selection pin (TPS61300/1) DC light-mode selection pin (TPS61300) Flash ready output, HW-reset input (TPS61301/5)	25	1.50
<b>LM3561</b>	2.5 to 5.5	1		600	1000/1500		✓	i <sup>2</sup> C	✓			WCSP-12	600-mA compact solution with integrated protection features	15	0.60
<b>LM3554</b>	2.5 to 5.5	2		1200	1000/1500/2000/2500		✓	i <sup>2</sup> C	✓		✓	WCSP-16	1.2-A inductive driver with protection features and voltage mode	23	1.30
<b>LM3555</b>	2.5 to 5.5	2		500	1250/1500/1750/2000			i <sup>2</sup> C	✓			WCSP-12	Series driver with 90% efficiency and indicator LED	31	1.30
<b>LM3556</b>	2.5 to 5.5	1		1500	1700/1900/2500/3100		✓	i <sup>2</sup> C	✓		✓	WCSP-16	4-MHz LED driver with tiny solution size and integrated protection features	18	0.50
<b>LM3559</b>	2.5 to 5.5	2		1800	1400/2100/2700/3200		✓	i <sup>2</sup> C	✓		✓	WCSP-16	1.8-A inductive flash LED driver with programmable indicator blinking	26	1.40
<b>LM3560</b>	2.5 to 5.5	2		2000	1600/2300/3000/3600		✓	i <sup>2</sup> C	✓			WCSP-16	1.8-A inductive flash LED driver with programmable indicator blinking	26	1.45
<b>LM3550</b>	2.5 to 5.5	4		5000	—	✓		i <sup>2</sup> C				LLP	Super-cap flash LED driver with optimal mode to limit power dissipation	—	1.95
<b>LM3642</b>	2.5 to 5.5	1		1500	1700/1900		✓	i <sup>2</sup> C	✓		✓	WCSP-9	4-MHz LED driver with tiny solution size and integrated protection features	18	0.35
<b>LM3565</b>	2.5 to 5.5	1		930	2300/2600/2900/3300		✓	i <sup>2</sup> C	✓		✓	WCSP-16	4-MHz dual series LED driver with tiny solution size and integrated protection features	26	0.35

<sup>1</sup>All of these devices have TX-Mask and safety timer DC/Flash.

\*Suggested resale price in U.S. dollars in quantities of 1,000.

New devices are listed in bold red.

# Display Power

## LED Drivers—Signage/Linear

### Design Factors

**Dot Correction** — Creates uniform LED brightness. Gives the ability to dynamically control the output current.

**Grayscale** — Provides an enhanced color spectrum per LED equivalent with the number of grayscale steps available.

**Output Voltage Monitor** — Monitors voltages at constant current output terminals to detect LED failure and short circuit.

**LED Open Detection** — Indicates a broken or disconnected LED at an output terminal.

**Thermal Error Flag** — Indicates an over-temperature condition.

**Watchdog Timer** — Turns output off when scan signal is stopped.

**Thermal Shutdown** — Turns output off when junction temperature exceeds its limit.

**Current Reference Short Flag** — Indicates whether the current set resistor is shorted to ground.

**Power Save Mode** — Reduces LED driver quiescent current when all outputs are off.

**LED Short Detection** — Indicates a shorted LED to ground at an output.

**Invisible Detection Mode** — Indicates LED Open and LED Short conditions while an output is off.

**Output Leakage Detection** — Indicates high resistance leakage from an output to ground.

### LED Display Drivers Function Guide

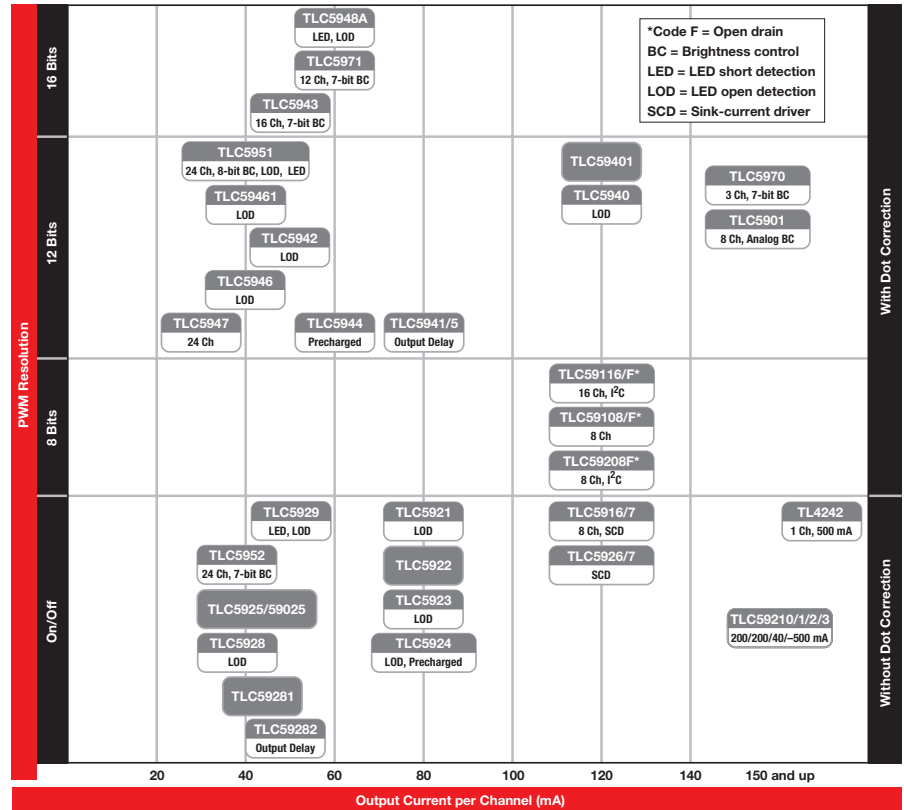

### 16-Channel LED Driver with 7-Bit Global Brightness, Power Save Mode, Full Diagnostics

#### TLC5929

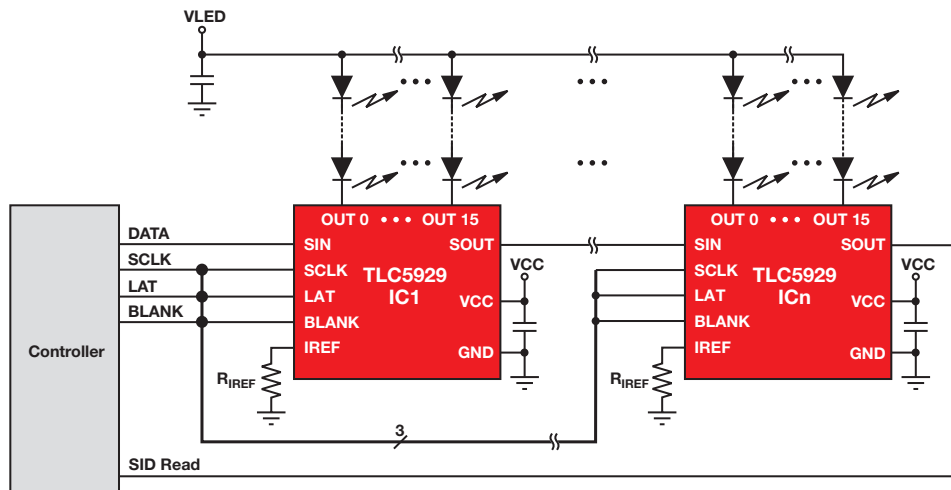

#### Key Features

- Complete LED diagnostics feature set monitors for all fault conditions
- Power Save mode reduces LED driver current consumption by 100x when image is off
- 33-MHz data transfer rate
- 2 ns per channel delayed switching

Get more information: [www.ti.com/product/TLC5929](http://www.ti.com/product/TLC5929)

# Display Power

## LED Drivers—Signage/Linear

### Selection Guide

Device	No. of Chan.	V <sub>IN</sub> (Min) (V)	V <sub>IN</sub> Max (V)	Output Current I <sub>LED</sub> (mA)	Channel-to-Channel Accuracy (%)	Dev.-to-Dev. Accuracy (%)	Recharged FET	Short Detection	Open Detection	Overtemperature Detection	Brightness Control (Bits)	Dot Correction (Bits)	PWM Grayscale Control (Bits)	Interface	Comments	Price*
TL4242	1	4.5	42	500	—	—		✓	✓	✓				—		0.35
TLC5916	8	3.3	5.5	120	±3 (Max)	±6 (Max)			✓	✓	8			SPI		0.47
TLC5917	8	3.3	5.5	120	±3 (Max)	±6 (Max)		✓	✓	✓	8			SPI		0.60
TLC59108	8	3	5.5	100	±3 (Max)	—			✓	✓	8		8	I <sup>2</sup> C	Constant-current output	0.80
TLC59108F	8	3	5.5	100	±3 (Max)	—			✓	✓	8		8	I <sup>2</sup> C	Open-drain output	0.80
TLC59208F	8	3	5.5	50	±3 (Max)	—			✓	✓	8		8	I <sup>2</sup> C	Open-drain output but changes the I <sup>2</sup> C addressing capability	0.65
TLC59116	16	3	5.5	100	±6 (Max)	—			✓	✓	8		8	I <sup>2</sup> C	Constant-current output	1.45
TLC59116F	16	3	5.5	100	±6 (Max)	—			✓	✓	8		8	I <sup>2</sup> C	Open-drain output	1.45
TLC59210	8	3	5.5	200	—	—								Parallel	Clear function and clock pin for data latch	0.60
TLC59211	8	3	5.5	200	—	—								Parallel	No clear function and clock pin for data latch	0.55
TLC59212	8	3	5.5	40	—	—								Parallel		0.48
TLC59213/A	8	3	5.5	−500	—	—								Parallel	“A” version has 15 ns (non-“A” is 25 ns)	0.70
TLC5921	16	4.5	5.5	80	±1	±4 (Max)			✓	✓				SPI		0.85
TLC5922	16	3	5.5	80	±1	±4						7		SPI		1.35
TLC5923	16	3	5.5	80	±1	±4			✓	✓		7		SPI		1.40
TLC5924	16	3	5.5	80	±1	±4	✓		✓	✓		7		SPI		1.50
TLC5925	16	3	5	45	±4 (Max)	±6 (Max)				✓				SPI		0.50
TLC59025	16	3	5	45	±4 (Max)	±6 (Max)				✓				SPI		0.55
TLC5926	16	3	5.5	120	±6 (Max)	±6 (Max)			✓	✓	8			SPI		0.60
TLC5927	16	3	5.5	120	±6 (Max)	±6 (Max)		✓	✓	✓	8			SPI		0.65
TLC5928	16	3	5.5	35	±1	±1			✓	✓				SPI		0.50
TLC59281	16	3	5.5	35	±1	±1								SPI		0.43
TLC59282	16	3	5.5	45	±0.6	±1								SPI	4-channel grouped delay	0.47
TLC5929	16	3	5.5	50	±1	±2		✓	✓	✓	7			SPI	Power save mode, invisible error detection, 10-V VLED	0.85
TLC5930	12	3	3.6	40	±1	—				✓	6	8	10	SPI		3.00
TLC5940	16	3	5.5	120	±1	±2			✓	✓		6	12	SPI		1.25
TLC59401	16	3	5.5	120 <sup>1</sup> /80 <sup>2</sup>	±1	+2/−2.7				✓		6	12	SPI		1.80
TLC5941	16	3	5.5	80	±1	±2			✓	✓		6	12	SPI		1.00
TLC5942	16	3	5.5	50	±1.5	±3			✓	✓		7	12	SPI		1.10
TLC5943	16	3	5.5	50	±1.5	±3		✓	✓	✓	7		16	SPI		1.50
TLC5944	16	3	5.5	60	±1	±3	✓	✓	✓	✓		6	12	SPI		1.10
TLC5945	16	3	5.5	80	±1	±2			✓	✓		6	12	SPI		1.10
TLC5946	16	3	5.5	40	±1	±2			✓	✓		6	12	SPI		1.00
TLC59461	16	3	5.5	40	±1	±2			✓	✓		6	12	SPI	No auto-off function	1.05
TLC5947	24	3	5.5	30	±2	±2				✓			12	SPI	30-V V <sub>LED</sub> , internal oscillator	1.40
TLC5948A	16	3	5.5	60	±0.6	±1		✓	✓	✓	7	7	16	SPI	Power save mode, invisible error detection, 10-V VLED	1.35
TLC5951	24	3	5.5	40	±1.5	±3		✓	✓	✓	8	7	12, 10, 8	SPI		3.00
TLC5952	24	3	5.5	35	±1	±3		✓	✓	✓	7			SPI		2.20
TLC5970	3	10	36	150	±0.5	±3		✓	✓	✓	7	7	12	Differential		3.30
TLC5971	12	3	17	60	±1	±1				✓	7		16	SPI	Integrated 3.3-V LDO	1.50

<sup>1</sup>Output current with V<sub>CC</sub> > 3.6 V.

<sup>2</sup>Output current with V<sub>CC</sub> ≤ 3.6 V.

\*Suggested resale price in U.S. dollars in quantities of 1,000.

Preview devices are listed in bold teal.

# Multi-Channel Power Management Units (PMUs)

## Ultra-Low-Power PMU for Metering and Energy-Harvesting Applications with Sub-500-nA $I_Q$

### TPS65290

PREVIEW

The TPS65290 is a new PMU for ultra-low-power applications. Primary application target is to reduce overall power consumption to a minimum in order to guarantee battery life-time of over ten years. The ultra-low quiescent current of the “always-on” sleep mode is in the range of hundreds of nA.

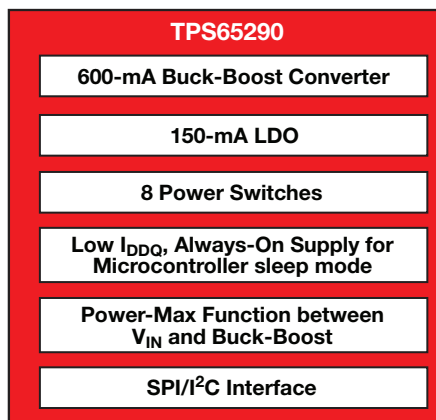

### Key Features

- 2.2- to 5.5-V input operating range
- 600-mA buck-boost converter
- 150-mA LDO is stable with 1- $\mu$ F ceramics
- Always-on bias supply for microcontroller sleep mode with sub-500-nA quiescent current
- Automatic power-max function between  $V_{IN}$  and buck-boost output
- 8 power switches
- Factory selectable SPI/I<sup>2</sup>C interface, GPIO interface
- -40 to 125°C junction temperature range
- 24-pin QFN package

### Applications

- Gas/water metering
- Energy harvesting
- Road/bridge safety monitor
- Low-power RF
- General purpose low-power applications

## Multiphase PMUs with Three Step-Down Converters

### TPS650380, TPS650381

The TPS650380/1 are multiphase 4-MHz PMU solutions for processor applications. The devices support low-voltage application processors in smartphones and tablets, including the latest submicron processes, and addressing digital voltage-scaling technologies such as SmartReflex™. All rails support an output-voltage range of 0.5 to 1.77 V—fully programmed via I<sup>2</sup>C.  $V_{OUT}$  can be increased to power 3-V or 3.3-V rails with an external output voltage divider.

The PMU features built-in automatic phase shedding and current balancing for the multi-phase rails. Multi-phase solutions enable operation at high efficiency over the complete load range, which is important for handling the varying load of processors and extending battery life.

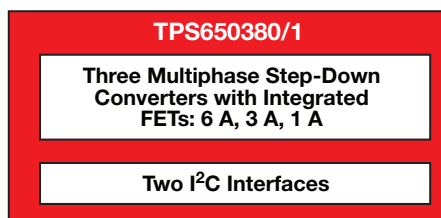

### Key Features

- Three step-down converters:
  - 3-phase: 5/6.8 A
  - 2-phase: 2/3.7 A
  - 1-phase: 1.8 A
- Two I<sup>2</sup>C high-speed compatible interfaces
- Soft start, Power Good indication, built-in sequencer
- Package: 49-bump, 3.25 x 3.25 mm<sup>2</sup> NanoFree™

### Applications

- Power for application processor for smart phones, tablets and ultrabooks/netbooks
- Power for DSP, ASIC and FPGA in industrial applications
- Dynamic voltage-scale compliant processors and DSPs
- Infotainment and telematics applications

Get more information: [www.ti.com/product/TPS650380](http://www.ti.com/product/TPS650380) or [TPS650381](http://www.ti.com/product/TPS650381)



# Multi-Channel Power Management Units (PMUs)

## Front-End PMU with Charger for Two- to Three-Cell Applications

### TPS65090

**NEW**

The TPS65090 is a single-chip power-management IC for portable applications, consisting of a battery charger with power-path management for a dual or triple Li-Ion or Li-Polymer cell battery pack. The charger can be directly connected to an external wall adapter. Three highly efficient step-down converters are targeted for providing a fixed 5-V system voltage, a fixed 3.3-V system voltage and an adjustable voltage rail. The device also has seven load switches built in. They can be used to control the power supply individually for certain circuit blocks in the application circuit. The current flowing through the load switches, the output current of the step-down converters, the input current from the AC adapter, and the charge current are monitored and can be read out using the digital interface.

#### Key Features

- Charger/power-path management:
  - Up to 4-A output current on the power path
  - Switch-mode charger: Up to 4-A charge current
- Three step-down converters:
  - High efficiency over a wide output-current range
  - Input-voltage range from 6 V to 17 V
  - Two fixed output voltages (5 V and 3.3 V), up to 6 A

- One adjustable output voltage (between 1.0 V and 3.3 V), up to 4 A
- Seven current-limited load switches:
  - One system voltage switch (backlight)
  - One 5-V switch (HDMI)
  - One 3.3-V switch (LTE/modem)
  - Four 3.3-V switches (LCD, camera, EMMC, SD)
  - All switches controlled by I<sup>2</sup>C interface
- Two always-on LDOs:
  - Two fixed output voltages (5 V and 3.3 V)
  - Output-voltage accuracy of ±1.0%
  - Typical 10-µA quiescent current per LDO

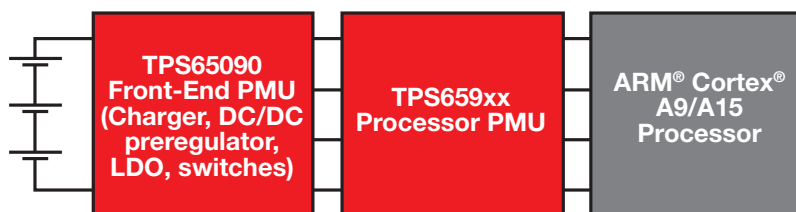

Get more information: [www.ti.com/product/TPS65090](http://www.ti.com/product/TPS65090)

## Processor PMU for ARM<sup>®</sup> Cortex<sup>™</sup> A15

**PREVIEW**

### TPS65914

The TPS65914 integrated PMU is for next-generation ARM Cortex A15 processors. The device provide seven configurable step-down converters with up to 9.0 A of output current. One of these configurable step-down converters can be combined with a 3.0-A regulator to allow up to 9.0 A of output current. The device also contain 11 LDOs. The power-up and power-down controller is configurable. The TPS65914 is available in a QFN package with a 0.5-mm pitch.

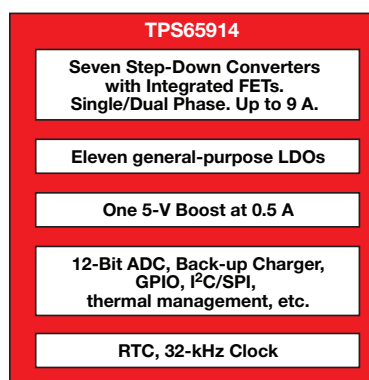

#### Key Features

- Seven step-down switch-mode regulators:
  - One 0.5- to 3.3-V at 6.0 A with DVS
  - One 0.5- to 3.3-V at 4.0 A with DVS
  - One 0.5- to 3.3-V at 3.0 A. Can be combined with the 6.0 A, resulting in 9.0 A.
  - Two 0.5- to 3.3-V at 2.0 A with DVS
  - Two 0.5- to 3.3-V at 1.0 A with DVS
- One 5-V output at 0.5 A for USB OTG, USB LDO and HDMI
- Eleven LDOs up to 300 mA
- Low-power ECO mode: 5 µA in off mode
- 12-bit sigma-delta ADC with 16 input channels
- Thermal monitoring

#### Applications

Cortex A15 processors  
Tablets and other portable devices

# Multi-Channel Power Management Units (PMUs)

## Selection Guide

Device	V <sub>IN</sub> (V)	No. of Regulator Outputs	Charger	Audio Codec	USB 2.0 OTG Transceiver	WLED Boost	DC/DC Step-Down Converter	DC/DC Step-Down Controller	LDO	Communication Interface	Description	Package(s)	Price*
<b>General Purpose PMUs</b>													
<b>TPS65280/1/2</b>	4.5 to 18.0	1	—	—	—	—	1	—	—	—	With 1 to 2 power switches	QFN-24	2.45
TPS65720/1	4.3 to 28.0	2	Linear	—	—	—	1	—	1	I <sup>2</sup> C	Smallest single Li-Ion applications, also QFN	WCSP-25	1.65
TPS65253	4.5 to 16.0	2	—	—	—	—	2	—	—	—	General purpose (3.5 A, 2.5 A)	QFN-28	2.95
TPS65270	4.5 to 16.0	2	—	—	—	—	2	—	—	—	General purpose (3 A, 2 A), good for 2 layers	QFN-28	2.95
LM26400Y	3.0 to 20.0	2	—	—	—	—	2	—	—	—	Dual buck	LLP-16	2.25
TPS65000/6	1.8 to 6.0	3	—	—	—	—	1	—	2	—	General purpose	QFN-16	1.40
TPS65250/1	4.5 to 18.0	3	—	—	—	—	3	—	—	—	General purpose	QFN-40	3.05
TPS65257/8	4.5 to 16	3	—	—	—	—	3	—	—	—	With 1/2 USB switches	QFN-40	3.25
LM3686	2.7 to 5.5	3	—	—	—	—	1	—	2	—	General purpose	SMD-12	0.95
LP3907	2.8 to 5.5	4	—	—	—	—	2	—	2	I <sup>2</sup> C	General purpose	SMD-25, LLP-24	2.28
LM26480	2.8 to 5.5	4	—	—	—	—	2	—	2	—	General purpose	LLP-24	1.90
LM3280	2.7 to 5.5	4	—	—	—	—	1	—	3	—	Battery powered RF	SMD-16	2.31
LP3910	2.7 to 5.5	5	Linear	—	—	—	3	—	2	I <sup>2</sup> C	Portable with buck-boost	LLP-48	3.95
TPS65053/8	2.5 to 6.0	5	—	—	—	—	2	—	3	—	Low-cost 5x channel PMU	QFN-24	1.85
TPS65050/1/2/4/6	2.5 to 6.0	6	—	—	—	—	2	—	4	Logic H/L	Low-cost 6x channel PMU	QFN-32	1.85
LP8720	2.7 to 4.5	6	—	—	—	—	1	—	5	I <sup>2</sup> C	General purpose	micro SMD-20	1.50
LP8725	2.6 to 4.5	9	—	—	—	—	2	—	7	I <sup>2</sup> C	General purpose	micro SMD-30	2.30
<b>ARM<sup>®</sup> Cortex<sup>™</sup>-R4</b>													
<b>TPS65381-Q1</b>	5.8 to 36	5	—	—	—	—	1	—	4	I <sup>2</sup> C	Safety-critical applications	HTSSOP-32	2.60
TPS659119-Q1	2.7 to 5.5	11	—	—	—	—	3	—	9	2x I <sup>2</sup> C	Flexible PMU with ext DC/DC controller option	HTQFP-80	5.72
<b>ARM Cortex A8 PMUs</b>													
TPS65070/2/3	2.8 to 6.3	5	Linear	—	—	Yes	3	—	2	I <sup>2</sup> C	With and without touch-screen controller	QFN-48	3.60
TPS65023x	2.5 to 6.0	6	—	—	—	—	3	—	3	I <sup>2</sup> C	Flexible 6x-channel PMU, also WCSP package	QFN-40	3.30
TPS650250	2.5 to 6.0	6	—	—	—	—	3	—	3	—	Flexible PMU with adj V <sub>OUT</sub>	QFN-32	2.20
TPS65217	2.7 to 6.5	7	Linear	—	—	Yes	3	—	4	—	Optimized for AM335x processors	QFN-48	3.45
TPS65921	2.7 to 4.5	7	—	—	Yes	—	3	—	4	2x I <sup>2</sup> C	Optimized for OMAP <sup>™</sup> 35x processors	BGA-139	3.60
TPS65930	2.7 to 4.5	7	—	Yes	Yes	—	3	—	4	2x I <sup>2</sup> C	Optimized for OMAP35x processors	BGA-139	3.95
<b>LP8765</b>	4.5 to 6.8	12	Linear	—	—	Yes	2	—	10	I <sup>2</sup> C	Smartphone PMU	micro SMD-49	3.00
TPS65950	2.7 to 4.5	13	Linear	Yes	Yes	—	3	—	10	2x I <sup>2</sup> C	Optimized for OMAP35x processors	BGA-209	4.50
TPS65951	2.7 to 4.5	13	—	Yes	Yes	—	3	—	10	2x I <sup>2</sup> C	Optimized for OMAP35x, 0.8-mm pitch	BGA-169	4.50
TPS65910x	2.7 to 5.5	13	—	—	—	—	3	—	9	2x I <sup>2</sup> C	Flexible PMU with 5-V boost	QFN-48	3.45
LP3925	4.5 to 6.5	18	Linear	—	—	Yes	3	—	15	I <sup>2</sup> C	Smartphone PMU	micro SMD-81	3.95
LP3974	4.5 to 6.5	20	Linear	—	—	—	4	—	16	I <sup>2</sup> C	Smartphone PMU	micro SMD-100	2.46
<b>ARM Cortex A9 PMUs</b>													
TPS659110/2/3/9	2.7 to 5.5	13	—	—	—	—	3	1	9	2x I <sup>2</sup> C	With DC/DC controller up to 10 A	BGA-98	4.45
TPS65862x/4x	4.3 to 6.5	14	Linear	—	—	Yes	3	—	11	I <sup>2</sup> C	Nvidia Tegra 2 and other microprocessors	BGA-121	5.95
TPS65912x	2.3 to 5.5	14	—	—	—	—	4	—	10	I <sup>2</sup> C/SPI	Flexible PMU with 4 DC/DC converters	WCSP-81	4.45
<b>LP8788</b>	4.5 to 6.5	26	Linear	—	—	Yes	4	—	22	I <sup>2</sup> C	Smartphone PMU	micro SMD-100	TBD
TWL6030/32/40/41	2.3 to 5.5	18	Switch	Yes	—	—	7	—	11	2x I <sup>2</sup> C	OMAP4 power and audio	FBGA + PBGA	6.35
<b>ARM Cortex A15 PMUs</b>													
<b>TPS650380</b>	2.5 to 5.5	3	—	—	—	—	3	—	—	2x I <sup>2</sup> C	Multiphase DC/DC technology	NanoFree <sup>™</sup> -49	TBD
<b>TPS659039-Q1</b>	3.15 to 5.5	12	—	—	—	—	7	—	5	2x I <sup>2</sup> C	Cortex A15 processors	nfBGA, mrQFN-st	TBD
<b>TPS65914</b>	2.3 to 5.5	18	—	—	—	1	6	—	11	2x I <sup>2</sup> C	Cortex A15 processors	WCSP, mrQFN	TBD
<b>TPS659038-Q1</b>	3.15 to 5.5	18	—	—	—	—	7	—	11	2x I <sup>2</sup> C	Cortex A15 processors	nfBGA, mrQFN-st	TBD

\*Suggested resale price in U.S. dollars in quantities of 1,000.

New devices are listed in bold red. Preview devices are listed in bold teal.

# Multi-Channel Power Management Units (PMUs)

## Selection Guide (Continued)

Device	V <sub>IN</sub> (V)	No. of Regulator Outputs	Charger	Audio Codec	USB 2.0 OTG Transceiver	WLED Boost	DC/DC Step-Down Converter	DC/DC Step-Down Controller	LDO	Communication Interface	Description	Package(s)	Price*
<b>Special Function PMUs</b>													
<b>TPS65200</b>	2.5 to 6.5	0	Switch	—	—	Yes	—	—	—	I <sup>2</sup> C	Front-end PMU with charger+WLED	WCSP, QFN	2.45
<b>TPS658310</b>	3.0 to 6.0	0	Switch	—	—	Yes	—	—	—	I <sup>2</sup> C	Front-end PMU with charger+flash+WLED	WCSP-49	3.45
<b>TPS65735/835</b>	2.5 to 6.4	2	Linear	—	—	—	—	—	1	—	3D glasses, x835 with MSP430™	QFN-40	1.25
<b>TPS65290</b>	2.5 to 5.5	2	—	—	—	—	1	—	1	I <sup>2</sup> C	Meters, energy-harvesting, +10-year battery	QFN-24	TBD
<b>TPS65320</b>	3.6 to 40	2	—	—	—	—	1	—	1	—	Eco-mode™ 3.2-A buck + LDO	HTSSOP-14	1.10
<b>LM10502</b>	2.5 to 5.5	3	—	—	—	—	2	—	1	SPI	PMU for SSD memory	micro SMD-34	0.80
<b>TPS65090</b>	5.0 to 17.0	5	Switch	—	—	—	3	—	2	I <sup>2</sup> C	Front-end PMU for 2 to 3 Li-Ion in series	QFN-100	4.95

\*Suggested resale price in U.S. dollars in quantities of 1,000.

New devices are listed in bold red. Preview devices are listed in bold teal.

## Embedded Processors Supported by TI Power-Management Units (PMUs)

Processor	Part Number	PMU
TI	C2834x	TPS65000, TPS650061
TI	C55x	TPS65000x
TI	C6742/6/8	TPS65910, TPS65070, TPS65023
TI	C6745/7	TPS65910, TPS65023
TI	C6A814x	TPS659113
TI	C6A816x	TPS659112
TI	DM335, DM355, DM365, DM367	TPS65053, TPS65070
TI	DM368	TPS650532, TPS65023
TI	DM385	TPS659113
TI	DM37x 800MHz	TPS6595x/30/2x/10, TPS65023, TPS650731
TI	DM37x 1GHz	TPS65950A3/x51/x21B1/x10, TPS65023, TPS650731
TI	DM643x, DM644x	TPS65023, TPS659105
TI	DM812x/ DM814x	TPS659113
TI	DM816x	TPS659112
TI	AM17x	TPS65910, TPS65000x, TPS650061, TPS65023
TI	AM18x	TPS65910, TPS65000x, TPS650061, TPS65070
TI	AM335x	TPS65910A/A3, TPS65217, TPS650250
TI	AM35x	TPS65910, TPS650732, TPS65023
TI	AM37x 800MHz	TPS6595x/30/2x/10, TPS65023, TPS650731
TI	AM37x 1GHz	TPS65950A3/x51/x21B1/x10, TPS65023, TPS650731
TI	AM387x	TPS659113
TI	AM389x	TPS659112
TI	RM4x, TMS570	TPS65381-Q1
TI	OMAP™3503/15/25/30	TPS6595x/30/2x/10, TPS65073x, TPS65023
TI	OMAP3611/21/30	TPS6595x/30/2x/10, TPS65023
TI	OMAP-L132, L137, L138	TPS65910, TPS65023, TPS650061, TPS65070
TI	OMAP4430/60/70	TWL6030, TWL6032
TI	Jacinto 6	TPS659038-Q1, TPS650939-Q1

Processor	Part Number	PMU
Altair	3100/6200	TPS659122
Ambarella	iOne	Please ask TI
Freescale	IMX25	TPS65051/2
Freescale	IMX27	TPS65053, TPS659107
Freescale	IMX35	TPS650250, TPS659107
Freescale	IMX508	TPS659108
Freescale	IMX51	TPS659109
Freescale	IMX53	TPS659106
Freescale	IMX6x	Please ask TI
Leadcore	LC1810	LP8788
Marvell	PXA270	TPS65021/2
Marvell	Armada	Please ask TI
Nvidia	Tegra 2	TPS658621/2/3, TPS658640/3
Nvidia	Tegra 3	TPS659110/9
Nvidia	Tegra 4	TPS65914
Nvidia	i450, i500	TPS659121
Rockchip	RK29	TPS659102
Rockchip	RK30	TPS65910x
Samsung	S5PV210, S5PC110	TPS659101
Samsung	S5PC100	TPS659103, LP3974
Samsung	S5P6440	TPS659104
Samsung	S5PV310	Please ask TI
Samsung	Exynos 4210	Please ask TI
STM	SPEAr 300	TPS650532
STM	SPEAr 1310	Please ask TI

Reference designs for these TI processor families are available online. Bookmark these pages to find new designs for the latest DSP and microprocessor generations.

PMU solutions with and without battery charger:

[www.ti.com/pmu](http://www.ti.com/pmu)

TI power-management reference designs:

[www.ti.com/processorpower](http://www.ti.com/processorpower)

# Power Protection, Distribution and Monitoring

## Overview

Distributing and controlling power—even after the correct voltage is derived—is becoming more complex. Because increasing numbers of voltage rails are required in today's advanced processing or embedded systems, distributing and managing these rails is a constant challenge.

Load switches, MUXes, or inrush-protection devices are routinely required

to safely route power where it is needed and deliver it properly. When power needs to be moved from system to system, issues like hot-swap control, safety certification, and monitoring quickly become top priorities.

Digital control takes all of these concerns and capabilities to yet another level.

Microprocessor control and monitoring in system health and power blocks gives

designers even more options to improve the robustness of their system. Using digital interfaces to various functional blocks and sensors, it is possible to monitor the power or current consumption, system temperature, or other variables, and then take action.

## Hot-Swap Control, Protection and Monitoring

### Protection Power Portfolio

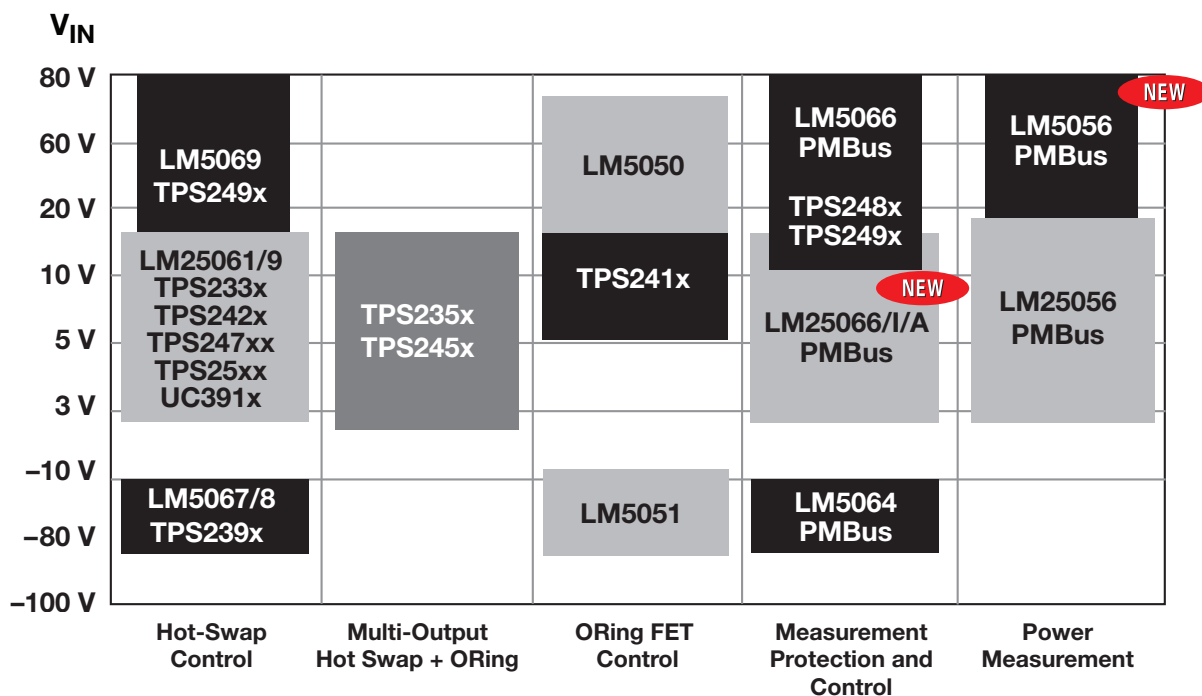

# Power Protection, Distribution and Monitoring

## Hot-Swap Control, Protection and Monitoring

### System Power Management and Protection IC with PMBus

#### LM25066, LM25066I, LM25066A

**NEW**

TI's PMBus-enabled system protection and management products combine hot swap control with embedded telemetry measurement, intelligence, and digital communications which enable them to deliver accurate power usage data back to the system to optimize power consumption, reduce operating expenses, and increase reliability

#### Key Features

- Intel Node Manager 2.0 compliant
- Hot swap with current and power limiting
- Adjustable current limit, circuit breaker thresholds
- Measure voltage, current, power and temperature
- Simultaneous sampling of current and voltage for true power measurement
- Peak and programmable average power capture
- Dynamic configuration of fault and warning levels
- I<sup>2</sup>C/SMBus interface with PMBus compliance

#### Applications

- Server backplane systems
- Base station power distribution systems
- Solid-state circuit breakers

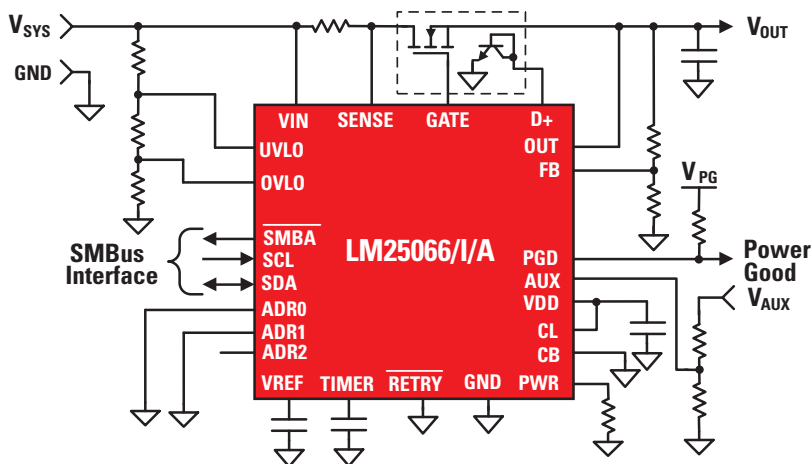

Typical application circuit.

Get more information: [www.ti.com/product/LM25066](http://www.ti.com/product/LM25066)

## Hot Swap Switches (Integrated FET) Selection Guide

Device	Target Applications	Channels	V <sub>IN</sub> (V)	Current Limit (A)	r <sub>DS(on)</sub> per FET (typ) (mΩ)	Enable/Shutdown	Ramp	Package(s)	Price*
TPS2420	Hot swap with current monitor & pwr limiting	1	3 to 20	1 to 5	20	1L	Current	16-pin SON	1.95
TPS2421-1	Hot swap with pwr limiting, latch-off on fault	1	3 to 20	1 to 5	20	1L	Current	SOIC-8	1.60
TPS2421-2	Hot swap with pwr limiting, retry on fault	1	3 to 20	1 to 5	20	1L	Current	SOIC-8	1.60
TPS2552	Current-limiting switch, constant-current	1	2.5 to 6.5	0.75 to 1.5	85	1L	Current	6-pin SOT-23, SON	0.70
TPS2552-1	Current-limiting switch, latch-off on fault	1	2.5 to 6.5	0.75 to 1.5	85	1L	Current	6-pin SOT-23, SON	0.70
TPS2553	Current-limiting switch, constant-current	1	2.5 to 6.5	0.75 to 1.5	85	1H	Current	6-pin SOT-23, SON	0.70
TPS2553-1	Current-limiting switch, latch-off on fault	1	2.5 to 6.5	0.75 to 1.5	85	1H	Current	6-pin SOT-23, SON	0.70
TPS2554	Current-limiting switch, constant-current	1	4.5 to 5.5	0.25 to 2.8	73	1H	Current	8-pin SON	0.80
TPS2555	Current-limiting switch, constant-current	1	4.5 to 5.5	0.25 to 2.8	73	1L	Current	8-pin SON	0.80
TPS2556	Current-limiting switch, constant-current	1	2.5 to 6.5	0.5 to 5	22	1L	Current	8-pin SON	0.90
TPS2557	Current-limiting switch, constant-current	1	2.5 to 6.5	0.5 to 5	22	1H	Current	8-pin SON	0.90
TPS2560/A	Current-limiting switch, constant-current	2	2.5 to 6.5	0.25 to 2.5	45	2L	Current	10-pin SON	0.90
TPS2561/A	Current-limiting switch, constant-current	2	2.5 to 6.5	0.25 to 2.5	45	2H	Current	10-pin SON	0.90
TPS2590	Current-limiting switch, configurable fault	1	3 to 20	1 to 5	20	1L	Current	16-pin SON	1.05
TPS25910	Current-limiting switch with internal FET, adj. ramp	1	3 to 20	1 to 6	30	1L	Adj. dv/dt	16-pin SON	1.05
UCC3915	Enclosure management, general	1	7 to 15	0 to 3	150	1L	Current	SOIC-16, TSSOP-24	2.55
UCC3912	RAID, SCSI, general	1	3 to 8	0 to 3	150	1L	Current	SOIC-16, TSSOP-24	2.30
UCC3918	RAID, SCSI, general	1	3 to 6	0 to 4	75	1L	Current	SOIC-16, TSSOP-24	2.35

\*Suggested resale price in U.S. dollars in quantities of 1,000.

# Power Protection, Distribution and Monitoring

## Hot-Swap Control, Protection and Monitoring

### Hot Swap Controllers (External FET) Selection Guide

Device	Target Applications	Channels	VIN Range (V)	Features <sup>1</sup>							Ramp	Power Limiting	Package(s)	Price*	
				Enable/Shutdown	UV	OV	Fault	PG	Latch	Auto Retry					
TPS2300/01	CompactPCI®, general	2	3 to 13/3 to 5.5	1L/1H	✓		✓	✓	✓		Voltage	No	20-pin TSSOP	1.60	
TPS2310/11	CompactPCI, general	2	3 to 13/3 to 5.5	1L/1H	✓		✓	✓	✓		Voltage	No	20-pin TSSOP	1.60	
TPS2320/21	CompactPCI, general	2	3 to 13/3 to 5.5	1L/1H	✓		✓	✓	✓		Voltage	No	16-pin SOIC/TSSOP	1.35	
TPS2330/31	CompactPCI, general	1	3 to 13	1L/1H	✓		✓	✓	✓		Voltage	No	14-pin SOIC/TSSOP	1.25	
UCC3919	Low-voltage general hot swap	1	3 to 8	1H			✓			S <sup>2</sup>	S <sup>2</sup>	Current	No	16-pin SOIC/TSSOP	2.35
TPS2342	CompactPCI, PCI-X®, PC-X2.0	12	3.3, V <sub>aux</sub> , V <sub>IO</sub> , 5, +12, -12	1L	✓			✓	✓		Voltage	No	80-pin HTQFP	7.00	
TPS2343	CompactPCI, PCI-X, PC-X2.0	12	3.3, V <sub>aux</sub> , V <sub>IO</sub> , 5, +12, -12	1L	✓			✓	✓		Voltage	No	80-pin HTVSOP	7.50	
TPS2350	Full featured -48-V telecom, LS active ORing	2	-12 to -80	1H	✓	✓	✓	✓		✓	Current	No	14-pin SOIC/TSSOP	1.90	
TPS2358	xTCA mezzanine cards, general 12 V	2	8.5 to 17	2L	✓		✓	✓	✓		Current	No	48-pin QFN	4.00	
TPS2359	xTCA mezzanine cards, general 12 V	2	8.5 to 17	1H/1L	✓	✓	✓	✓	S <sup>2</sup>	S <sup>2</sup>	Current	No	36-pin QFN	5.00	
TPS2363	PCI Express®	6	3.3 V <sub>aux</sub> , 3.3, +12	1L	✓		✓	✓	✓		Voltage	No	48-pin QFP	2.50	
TPS2390	Simple -48-V telecom	1	-36 to -80	1H			✓				Current	No	8-pin MSOP	1.00	
TPS2391	Simple -48-V telecom	1	-36 to -80	1H			✓			✓	Current	No	8-pin MSOP	1.00	
TPS2392	Full featured -48-V telecom	1	-20 to -80	1H	✓	✓	✓	✓			Current	No	14-pin TSSOP	1.35	
TPS2393	Full featured -48-V telecom	1	-20 to -80	1H	✓	✓	✓	✓		✓	Current	No	14/44-pin TSSOP	1.35	
TPS2393A	Full featured -48-V telecom (Fast retry)	1	-20 to -80	1H	✓	✓	✓	✓		✓	Current	No	14-pin TSSOP	1.35	
TPS2394	Full featured, ESD ruggedized -48-V hotswap	1	-12 to -80	1H	✓	✓	✓	✓		✓	Current	No	14-pin TSSOP	1.35	
TPS2398	Simple -48-V telecom with PG	1	-36 to -80	1H				✓	✓		Current	No	8-pin MSOP	1.35	
TPS2399	Simple -48-V telecom with PG	1	-36 to -80	1H				✓		✓	Current	No	8-pin MSOP	1.35	
TPS2400	Overvoltage/undervoltage protection IC	1	2 to 100	1H	✓	✓			✓		—	No	5-pin SOT-23	0.80	
TPS2456	Inrush controller with reverse current control	2	8.5 to 15	2H	✓		✓	✓	✓		Current	No	36-pin QFN	3.75	
TPS2458	xTCA mezzanine cards, general 12 V	1	8.5 to 15	1L	✓		✓	✓	✓		Current	No	32-pin QFN	2.00	
TPS2459	xTCA mezzanine cards, general 12 V	1	8.5 to 15	1H/1L	✓	✓	✓	✓	S <sup>2</sup>	S <sup>2</sup>	Current	No	32-pin QFN	2.50	
TPS24700	Industrial, mass storage, servers, telecom	1	2.5 to 18	1H	✓			✓	✓		Current	No	8-pin MSOP	1.10	
TPS24701	Industrial, mass storage, servers, telecom	1	2.5 to 18	1H	✓			✓		✓	Current	No	8-pin MSOP	1.10	
TPS24710	Industrial, mass storage, servers, telecom	1	2.5 to 18	1H	✓		L	L	✓		Current	Yes	10-pin MSOP	1.25	
TPS24711	Industrial, mass storage, servers, telecom	1	2.5 to 18	1H	✓		L	L		✓	Current	Yes	10-pin MSOP	1.25	
TPS24712	Industrial, mass storage, servers, telecom	1	2.5 to 18	1H	✓		H	H	✓		Current	Yes	10-pin MSOP	1.25	
TPS24713	Industrial, mass storage, servers, telecom	1	2.5 to 18	1H	✓		H	H		✓	Current	Yes	10-pin MSOP	1.25	
TPS24720	Industrial, mass storage, servers, telecom	1	2.5 to 18	1H	✓	✓	✓	✓	S <sup>2</sup>	S <sup>2</sup>	Current	Yes	16-pin SON	1.40	
TPS2490	Servers, basestations, +48 V, +12 V	1	9 to 80	1H	✓			✓	✓		Current	Yes	10-pin MSOP	1.40	
TPS2491	Servers, basestations, +48 V, +12 V	1	9 to 80	1H	✓			✓		✓	Current	Yes	10-pin MSOP	1.40	
TPS2492	Servers, basestations, industrial, +48 V, +12 V	1	9 to 80	1H	✓	✓	✓	✓	✓		Current	Yes	14-pin TSSOP	1.45	
TPS2493	Servers, basestations, industrial, +48 V, +12 V	1	9 to 80	1H	✓	✓	✓	✓		✓	Current	Yes	14-pin TSSOP	1.45	
LM25069	12-V hotswap controller with power limiting	1	2.9 to 17	1H	✓	✓	✓	H	-1	-2	Current	Yes	10-pin MSOP	1.19	
LM25061	12-V hotswap controller with power limiting	1	2.9 to 17	1H	✓		✓	H	-1	-2	Current	Yes	10-pin MSOP	1.33	
LM5060/Q	Low Iq high-side protection controller	1	5.5 to 65	1H	✓	✓	✓	L	✓		Voltage	No	10-pin MSOP	1.28/1.40	
LM5069	+48-V hotswap controller with power limiting	1	9 to 80	1H	✓	✓	✓	H	-1	-2	Current	Yes	10-pin MSOP	1.35	
LM5068	Simple -48-V hotswap controller family	1	-10 to -90	1H	✓	✓	✓	H/H/L/L	-1/-3	-2/-4	Current	No	8-pin MSOP	1.35	
LM5067	-48-V hotswap controller with power limiting	1	-9 to -80	1H	✓	✓	✓	H	-1	-2	Current	Yes	10-pin MSOP/14-pin SOIC	1.50	

<sup>1</sup>Pin function: L = active low, H = active high.

<sup>2</sup>S = Selectable.

\*Suggested resale price in U.S. dollars in quantities of 1,000.

# Power Protection, Distribution and Monitoring

## Hot-Swap Control, Protection and Monitoring

### Protection and Monitoring with PMBus/I<sup>2</sup>C Selection Guide

Device	V <sub>IN</sub> Range (V)	Enable/Shutdown	UV	OV	Fault	PG	Latch	Auto Retry	Interface	Power Limiting	Package(s)	Price*
LM25066/A	2.9 to 17	1H	✓	✓	✓	✓	Prog	Prog	I <sup>2</sup> C, SMBus, PMBus	Yes	24-pin LLP	2.45/2.95
<b>LM25066/A</b>	2.9 to 17	1H	✓	✓	✓	✓	Prog	Prog	I <sup>2</sup> C, SMBus, PMBus	Yes	24-pin LLP	2.45/2.95
TPS2480/1	9 to 80	1H	✓			✓	✓		I <sup>2</sup> C	Yes	20-pin TSSOP	3.00
LM5066	10 to 80	1H	✓	✓	✓	✓	Prog	Prog	I <sup>2</sup> C, SMBus, PMBus	Yes	28-pin eTSSOP	3.95
LM5064	-10 to -80	1H	✓	✓	✓	✓	Prog	Prog	I <sup>2</sup> C, SMBus, PMBus	Yes	28-pin eTSSOP	3.95

\*Suggested resale price in U.S. dollars in quantities of 1,000.

New devices are listed in **bold red**.

### Monitoring with PMBus/I<sup>2</sup>C Selection Guide

Device	V <sub>IN</sub> Range (V)	Enable/Shutdown	Fault	Telemetry Data				Interface	Package(s)	Price*
				V <sub>IN</sub>	I <sub>IN</sub>	P <sub>IN</sub>	Temp			
LM25056/A	3 to 17	1H	✓	✓	✓	✓	✓	I <sup>2</sup> C, SMBus, PMBus	24-pin LLP	1.50/1.70
LM5056	10 to 80	1H	✓	✓	✓	✓	✓	I <sup>2</sup> C, SMBus, PMBus	28-pin TSSOP	2.49

\*Suggested resale price in U.S. dollars in quantities of 1,000.

### ORing Controllers Selection Guide

Device	Description	Channels	V <sub>IN</sub> Range (V)	Enable/Shutdown	UV	OV	Fault	PG	ORing Linear Gate Drive	On/Off ORing Function	Package(s)	Price*
TPS2410	ORing FET controller/MUX controller	1	0.8 to 16.5	1H	✓	✓	✓	✓	✓		14-pin TSSOP	1.70
TPS2411	ORing FET controller/MUX controller	1	0.8 to 16.5	1H						✓	14-pin TSSOP	1.70
TPS2412	ORing FET controller	1	0.8 to 16.5						✓		8-pin SOIC, 8-pin TSSOP	1.20
TPS2413	ORing FET controller	1	0.8 to 16.5							✓	8-pin SOIC, 8-pin TSSOP	1.20
TPS2419	ORing FET controller with OV/enable	1	3 to 16.5	1H		✓				✓	8-pin SOIC	1.20
LM5050-1	Positive HV ORing controller with AUX input	1	5 to 80	L					✓	✓	6-pin TSOT	1.25
LM5050-2	Positive HV ORing controller with FET test	1	6 to 80	L			✓		✓	✓	6-pin TSOT	1.25
LM5051	Negative HV ORing controller with FET test	1	-6 to -100	L			✓		✓	✓	8-pin SOIC	1.25
TPS2456	Inrush/reverse current controller for dual sources	2	8.5 to 15	2H	✓		✓	✓	✓		36-pin QFN	3.45
TPS2358	Dual 12-V/3.3-V hotswap/ORing controller	2	8.5 to 15	2L							48-pin QFN	4.00
TPS2359	Dual 12-V/3.3-V hotswap/ORing controller	2	8.5 to 15	Via I <sup>2</sup> C							36-pin QFN	5.00

\*Suggested resale price in U.S. dollars in quantities of 1,000.

# Power Protection, Distribution and Monitoring

## Current-Limited and Non-Current-Limited Load Switches

### Portable Electronics Integrated Load Switches Product Portfolio

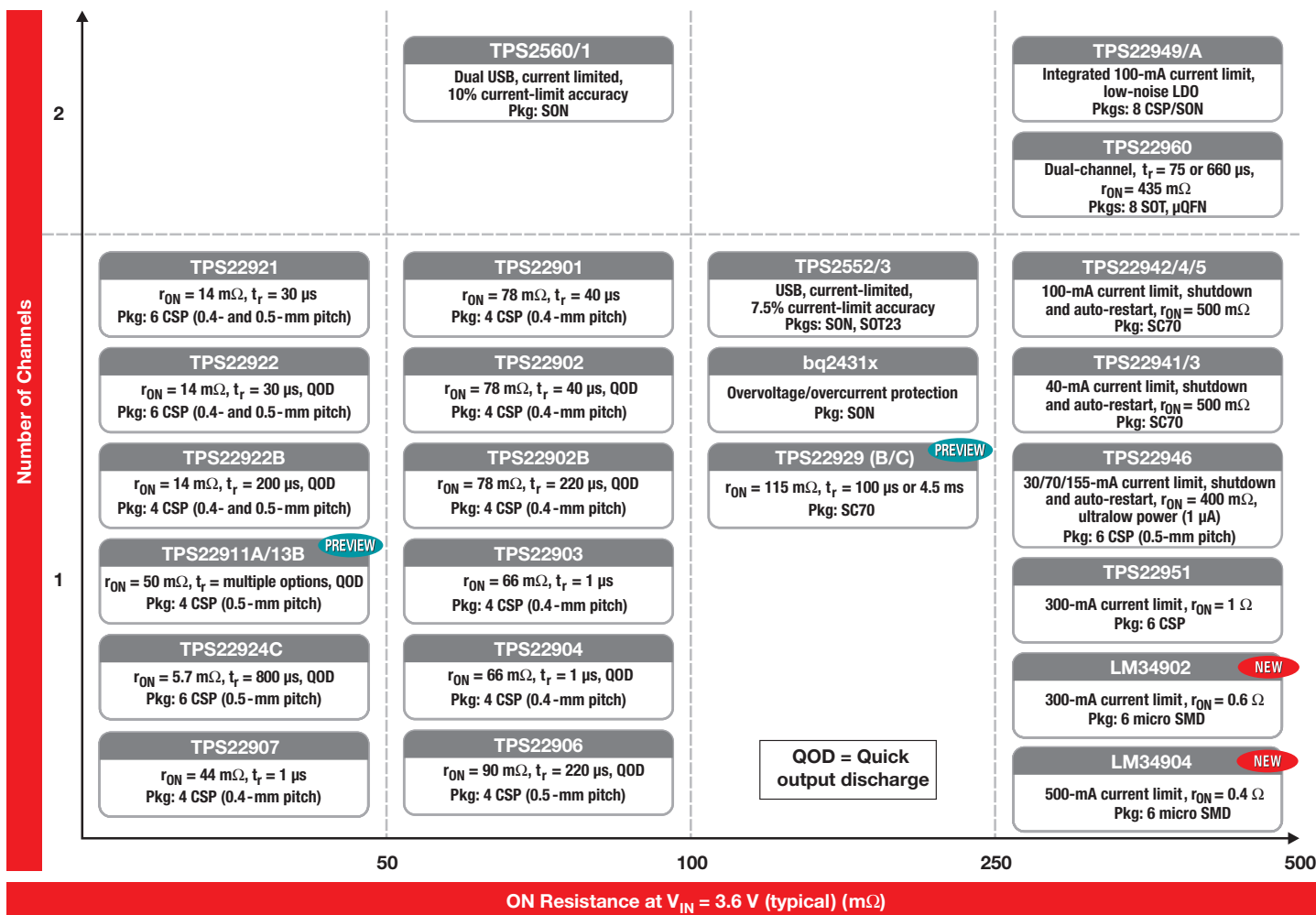

### The Integration/Size Advantage of Load Switches

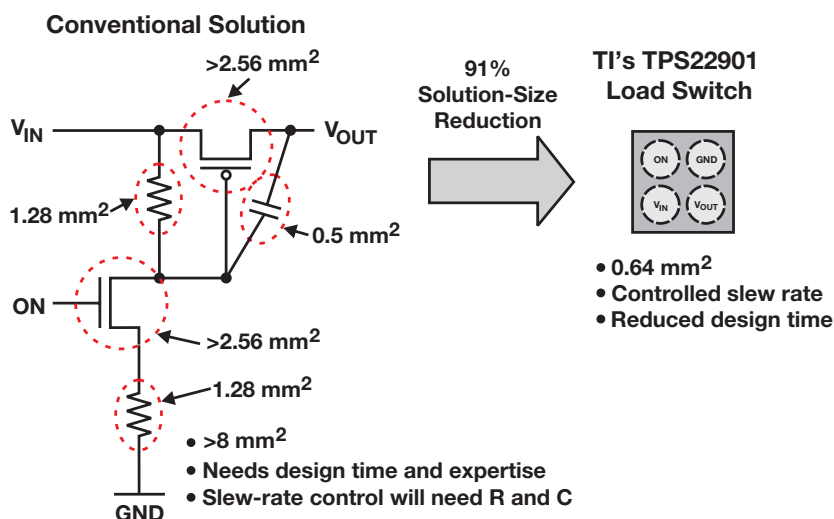



# Power Protection, Distribution and Monitoring

## Current-Limited and Non-Current-Limited Load Switches

### Non-Current-Limited Load Switches Product Portfolio

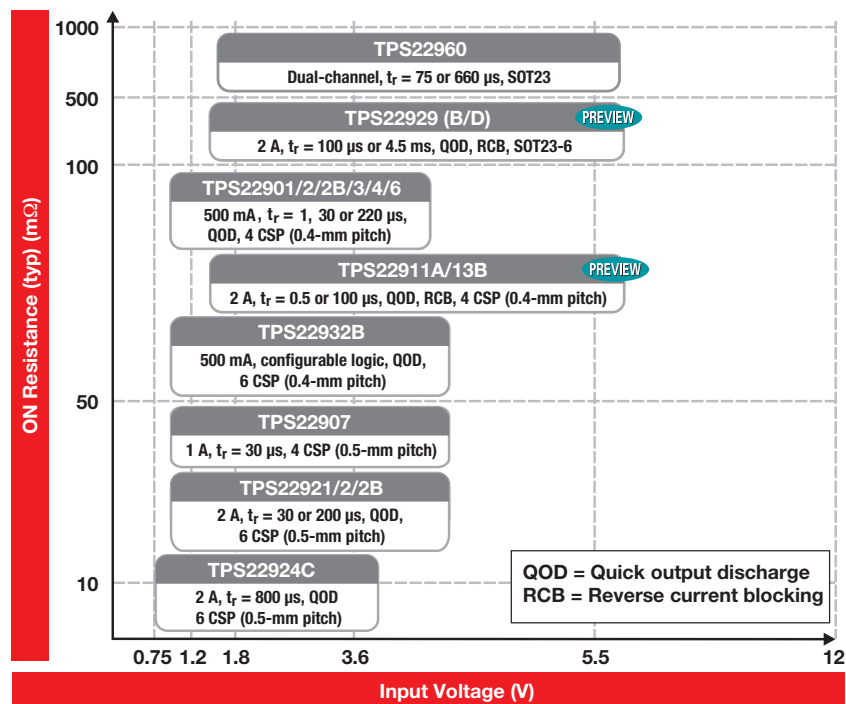

### Selection Guide

Device	Input Voltage Range (V)	Number of Channels	r <sub>ON</sub> at 3.6 V (mΩ)	Output Rise Time (μs)	Quick Output Discharge	Max Output Current	Enable	Package(s)	Price*
<b>Non-Current-Limiting Load Switches</b>									
TPS22901	1.0 to 3.6	1	78	40	No	500 mA	Active high	CSP (0.8x0.8 mm)	0.32
TPS22902/B	1.0 to 3.6	1	78	40/220	Yes	500 mA	Active high	CSP (0.8x0.8 mm)	0.32
TPS22903	1.1 to 3.6	1	66	1	No	500 mA	Active high	CSP (0.8x0.8 mm)	0.32
TPS22906	1.0 to 3.6	1	90	220	Yes	500 mA	Active high	CSP (0.9x0.9 mm)	0.32
TPS22907	1.1 to 3.6	1	44	36	No	1 A	Active high	CSP (0.9x0.9 mm)	0.38
TPS22921	0.9 to 3.6	1	14	30	No	2 A	Active high	CSP (0.8x1.2 mm or 0.9x1.4 mm)	0.43
TPS22922/B	0.9 to 3.6	1	14	30/200	Yes	2 A	Active high	CSP (0.8x1.2 mm or 0.9x1.4 mm)	0.43
TPS22924B/C	0.75 to 3.6	1	18.3	100/800	Yes	2 A	Active high	CSP (0.9x1.4x0.4/0.5 mm)	0.28
TPS22920	0.75 to 3.6	1	5.3	800	Yes	4 A	Active high	CSP, 0.9x1.9 mm	0.34
TPS22966	0.8 to 5.5	2	15	Adj.	Yes	6 A	Active high	SON-14, 3x2 mm	0.44
<b>Non-Current-Limiting Load Switches with Reverse Current Protection</b>									
TPS22910A	1.4 to 5.5	1	61	1	No	2 A	Active low	CSP (0.9x0.9x0.5 mm)	0.24
TPS22913B	1.4 to 5.5	1	61	100	Yes	2 A	Active high	CSP (0.9x0.9x0.5 mm)	0.24
TPS22913C	1.4 to 5.5	1	61	1000	Yes	2 A	Active high	CSP (0.9x0.9x0.5 mm)	0.24
TPS22912C	1.4 to 5.5	1	61	1000	No	2 A	Active high	CSP (0.9x0.9x0.5 mm)	0.24
TPS22929D	1.4 to 5.5	1	115	4000	Yes	2 A	Active high	SOT23-6 (3x3 mm)	0.24

Device	Input Voltage Range (V)	r <sub>ON</sub> at 1.8 V (Ω)	Current Limit (mA)	Current-Limit Blanking Time (ms)	Auto-Restart Time (ms)	Active	Package(s)	Price*
<b>Current-Limiting Load Switches</b>								
TPS22941	1.62 to 5.5	1.1	40	10	80	Low	5 SC70	0.42
TPS22942	1.62 to 5.5	1.1	100	10	80	Low	5 SC70	0.42
TPS22943	1.62 to 5.5	1.1	40	0	—	High	5 SC70	0.42
TPS22944	1.62 to 5.5	1.1	100	0	—	High	5 SC70	0.42
TPS22945	1.62 to 5.5	1.1	100	10	80	High	5 SC70	0.42
TPS22946	1.62 to 5.5	0.6	155/70/30	10	70	High	6 CSP	0.55
TPS22949/A	1.62 to 4.5	1	100	12	70	High	8 CSP/SON	0.70
TPS22951	2.8 to 5.3	1	600	—	—	High	6 CSP	0.45
LM34902/4	2.8 to 5.3	0.6/0.4	300/500	—	—	High	micro SMD-6	0.29/0.33

\*Suggested resale price in U.S. dollars in quantities of 1,000.

New devices are listed in bold red. Preview devices are listed in bold teal.

# Power Protection, Distribution and Monitoring

## Power-over-Ethernet (PoE)

The concept of providing power along with data is as old as basic telephone service, but the formal standard for providing power along Ethernet lines is much more recent. Though the original Power-over-Ethernet (PoE) specification was approved in 2005, the IEEE ratified a superseding standard in summer 2009—the IEEE 802.3at. Both standards specify behavior for devices receiving power across Ethernet lines, known as powered devices (PDs), and methods for injecting power onto the line, used in equipment known as power sourcing equipment (PSE).

### Original PoE . . . Only Better!

The vast majority of PoE applications need less than 12.95 W. For this growing market area, TI has a large portfolio of options to consider.

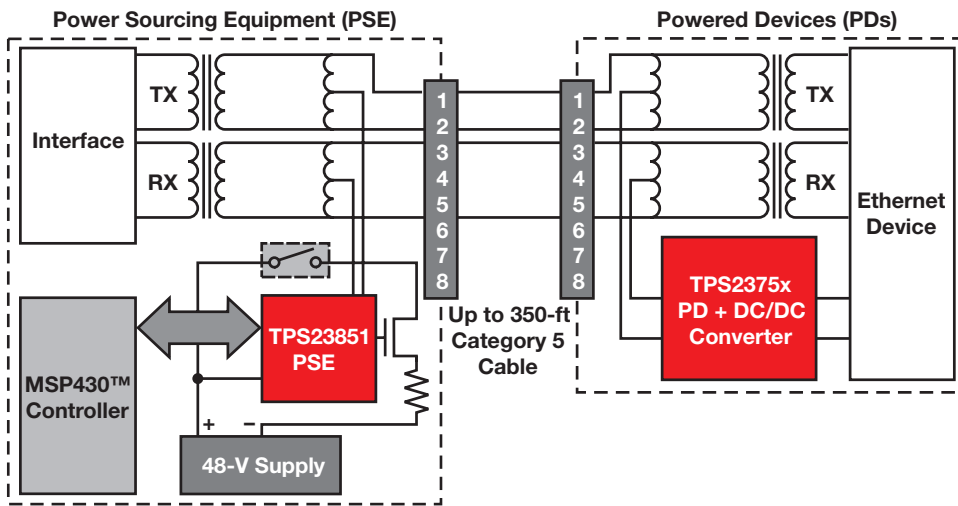

#### TPS23753A

- Simplest, most elegant, lowest-cost solution for a standard PoE PD
- Incorporates rugged tolerance for extended ESD exposure
- Auxiliary power supplies are fully supported—down to 12 V

#### TPS23750

- TI's original PD front end plus DC/DC converter
- Supports simple, low-cost, non-isolated buck-converter topologies with no transformer required

**New PoE Products  
for a New Standard**

The new TPS23851 and TPS2375x are IEEE 802.3at-compliant power-management ICs designed for managing the connection between PSE and PDs over Ethernet cables. The TPS23851 is a quad-port PSE power manager with external FETs and individual ADCs per port for maximum monitoring and control.

Get more information: [www.ti.com/poe](http://www.ti.com/poe)

## IEEE 802.3at PoE High-Power PD Interface

### TPS2378, TPS2379, TPS23751, TPS23752

**NEW**

The TPS2378 and TPS2379 PDs are specifically designed for high-power POE systems such as surveillance system cameras and wireless access points. Full 802.3at compliance along with a large and growing collection of proven reference

designs makes it easy to create a robust, rugged and compliant PD system.

#### Key Features

- TPS2378 – Programmable AUX input that forces load to be powered from AUX supply if available

- TPS2379 – Gate drive for external NFET allows designer to select external FET for desired current limit
- 802.3at-compliant hardware
- 100-V monolithic process

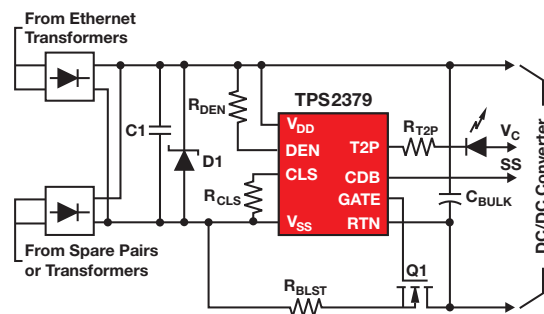
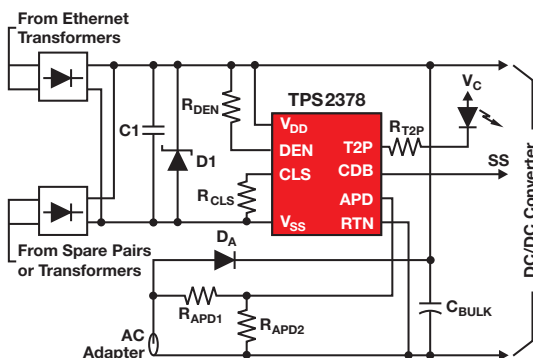

Get more information: [www.ti.com/product/TPS2378](http://www.ti.com/product/TPS2378), [TPS2379](http://www.ti.com/product/TPS2379), [TPS23751](http://www.ti.com/product/TPS23751) or [TPS23752](http://www.ti.com/product/TPS23752)

# Power Protection, Distribution and Monitoring

## Power-over-Ethernet (PoE)

### Selection Guide

Device	Description	Abs Max $V_{IN}$ (V)	Operating Temp (°C)	Full Inrush Current Limiting	Current Limit (mA)	Second Gate Driver for Maximum Efficiency	Package(s)	Price*
<b>Power-over-Ethernet (PoE) Powered Device (PD) Controllers with Integrated DC/DC Controllers</b>								
<b>TPS23750/70</b>	Integrated PD with PWM controller	100	-40 to 85	Fixed	405	No	TSSOP-20	1.50
<b>TPS23753A</b>	PD+controller with AUX ORing	100	-40 to 85	Fixed	405	No	TSSOP-14	1.45
<b>TPS23754/6</b>	High-power PD + high-efficiency controller	100	-40 to 125	Fixed	850	Yes	TSSOP-20 PowerPAD™	1.90
<b>TPS23757</b>	PD + high-efficiency controller	100	-40 to 125	Fixed	405	Yes	TSSOP-20	1.65
<b>TPS23751/2</b>	PD with Green Mode PWM	100	-40 to 85	Fixed	800	No - VF	TSSOP-20	1.50
<b>LM5070</b>	Integrated PD with PWM controller	80	-40 to 125	Prog	500	No	TSSOP-16	1.45
<b>LM5071</b>	Integrated PD with PWM controller and AUX interface	80	-40 to 125	Fixed	390	No	TSSOP-16	1.45
<b>LM5072</b>	Integrated PD with PWM controller and AUX control	100	-40 to 125	Prog	800	No	TSSOP16	1.85

Device	Description	Detection	Classification	Abs Max $V_{IN}$ (V)	Operating Temp (°C)	Full Inrush Current Limiting	Current Limit (mA)	Auto Retry or Latch Off in Fault	UVLO	DC/DC Interface	Package(s)	Price*
<b>Power-over-Ethernet (PoE) Powered Device (PD) Interface Front-End Controllers</b>												
<b>TPS2375/-1</b>	Powered device controller	4	Yes, Class 0-4	100	-40 to 85	Programmable	450	Latch Off/Retry	802.3af (30.6/39.4 V)	PG	SOIC-8, TSSOP-8/TSSOP-8	1.00
<b>TPS2376</b>	Powered device controller	4	Yes, Class 0-4	100	-40 to 85	Programmable	450	Latch Off	Adjustable	PG	SOIC-8, TSSOP-8	1.00
<b>TPS2376-H</b>	High-power PD controller	4	Yes, Class 0-4	100	-40 to 85	Programmable	600	Auto Retry	Adjustable	PG	SOIC-8	1.25
<b>TPS2377</b>	Powered device controller	4	Yes, Class 0-4	100	-40 to 85	Programmable	450	Latch Off	Legacy (30.5/35.0 V)	PG	SOIC-8, TSSOP-8	1.00
<b>TPS2377-1</b>	Powered device controller	4	Yes, Class 0-4	100	-40 to 85	Programmable	450	Auto Retry	Legacy (30.5/35.0 V)	PG	SOIC-8	1.00
<b>TPS2378</b>	PD with AUX control	4	Yes, Class 0-4	100	-40 to 85	Fixed	800	Auto Retry	30.5/35	PG	SOIC-8	1.00
<b>TPS2379</b>	PD with high power	4	Yes, Class 0-4	100	-40 to 85	Fixed	800	Auto Retry	30.5/35	PG	SOIC-8	1.00
<b>LM5073</b>	PD controller w/AUX control	4	Yes, Class 0-4	100	-40 to 85	Programmable	800	Auto Retry	Adjustable	PG	TSSOP-14	1.30

Device	Applications	Channels	Abs Max $V_{IN}$ (V)	Operating Temp (°C)	IEEE Compliant	Interface	Disconnect	Measurements	Power FET	Package	Price*
<b>Power-over-Ethernet (PoE) Power Sourcing Equipment (PSE) Controllers</b>											
<b>TPS2384</b>	Routers, switches, SOHO hubs, midspans	4	80	-40 to 125	802.3af	i <sup>2</sup> C	Both AC and DC	Current, voltage, capacitance and temperature	Internal	64-pin LQFP	4.75
<b>TPS23841</b>	Proprietary, higher-power 24-V/48-V PoE switches, hubs, midspans	4	80	-40 to 125	802.3af	i <sup>2</sup> C	Both AC and DC	Current, voltage, capacitance and temperature	Internal	64-pin LQFP	7.50
<b>TPS23851</b>	High power PoE for switches, hubs, midspans and industrial applications	4	70	-20 to 125	802.3at Type 1 & 2	i <sup>2</sup> C	Both AC and DC	Current, voltage and temperature	External	36-pin SSOP	4.50

\*Suggested resale price in U.S. dollars in quantities of 1,000.

New devices are listed in **bold red**.

# Power Protection, Distribution and Monitoring

## USB and Power Switches

### USB Current-Limiting Power Switches

Power switches are used to intelligently turn power on/off and provide fault protection. They are effective for power sequencing or segmentation and when controlled allocation of power is needed to circuit blocks, modules, add-in cards or cabled connections.

Universal Serial Bus (USB) ports are great examples of where this intelligent protection is vital for protecting your power supply and achieving regulatory compliance. TI's family of low-cost power switches are an excellent solution for USB port designs.

To minimize voltage drop, select devices with the lowest  $r_{DS(on)}$  or drain-to-source on-resistance.

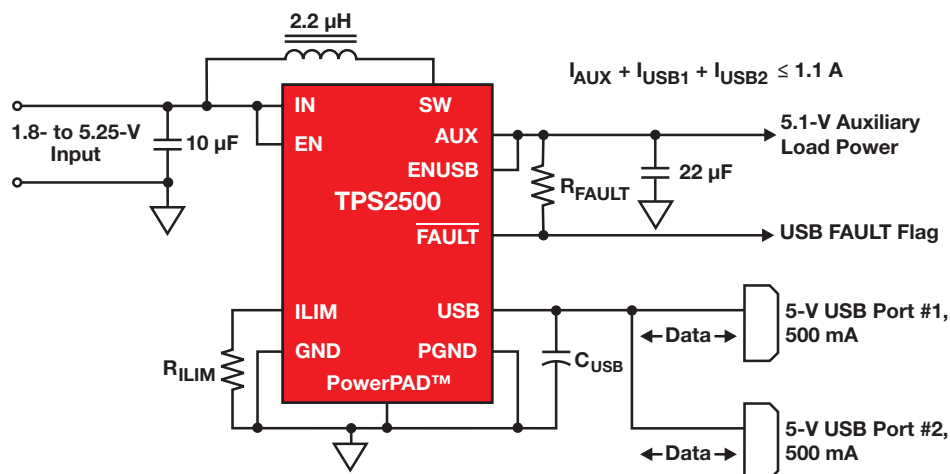

The TPS2500/1 combines a boost converter and a current-limiting switch for USB applications where the 5-V rail is not available. It is also a good choice for devices with 1.8-V, 2.5-V or 3.3-V rails.

### Current-Limited Switch Matrix

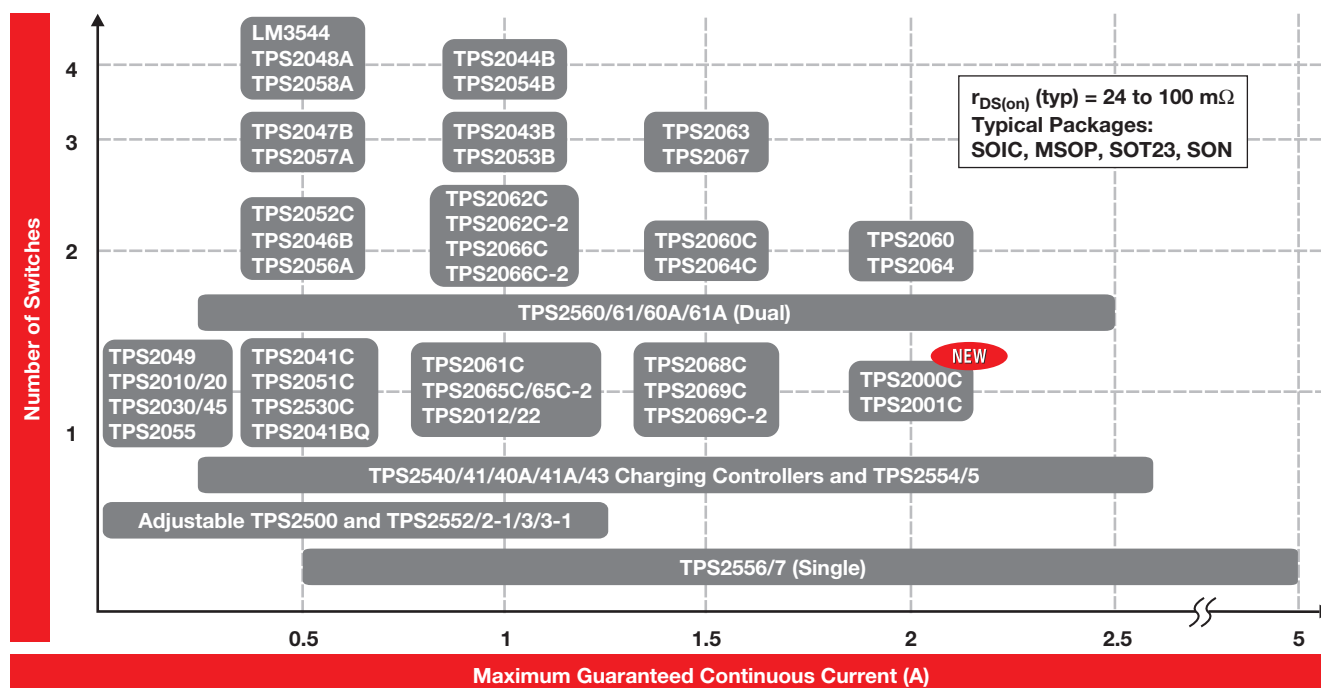

# Power Protection, Distribution and Monitoring

## USB and Power Switches

### USB Mobile Device Charging

What is universal charging?

Consumers have long desired a universal device to charge their many mobile electronic devices. Governments (like the European Union and China) and industry groups around the world are now moving to provide just such a framework, with three goals:

1. Provide a universal form factor—the USB interface (Standard-A plug to Micro-B plug)
2. Minimize environmental impact by reducing electronics waste and no-load power consumption
3. Reduce charging times when possible

Consumers will soon expect all USB host ports to be able to charge their devices. So, if your design calls for a USB port, compliance with this standard should be part of your next product release. Common products for which consumers may want a USB charging port include LCD TVs, set-top boxes, notebook/desktop PCs and dedicated charging AC adapters. For all of these devices, the TPS254x family may be a good choice.

The TPS2540 takes the standard USB power switch and combines it with the special data signaling required to comply with Universal Charger Solution (UCS) requirements. This makes it possible for a USB port to quickly charge UCS-compliant devices and even many popular, proprietary devices that predate the standard (such as Apple devices). All this is accomplished without any special software.

The TPS2540/41/40A/41A/43 are fully released. Order an evaluation board or some samples today!

### Battery Charging 1.2 (BC 1.2)

BC 1.2 defines the type of charger, handshaking, allowable current draws, and PD decision-making flowchart that defines the interaction between PD and the host charger.

BC 1.2 Port Type	Definition	5-V Current Capability
Standard Downstream Port (SDP)	Compliant USB 2.0 port. No special charging capability	Up to 500 mA
Dedicated Charging Port (DCP)	Wall charger. No data communication capability	Up to 1.5 A
Charging Downstream Port (CDP)	A USB 2.0 compliant port with intelligent charging capability	Up to 500 mA if authenticated as SCP or up to 1.5 A if authenticated as CDP

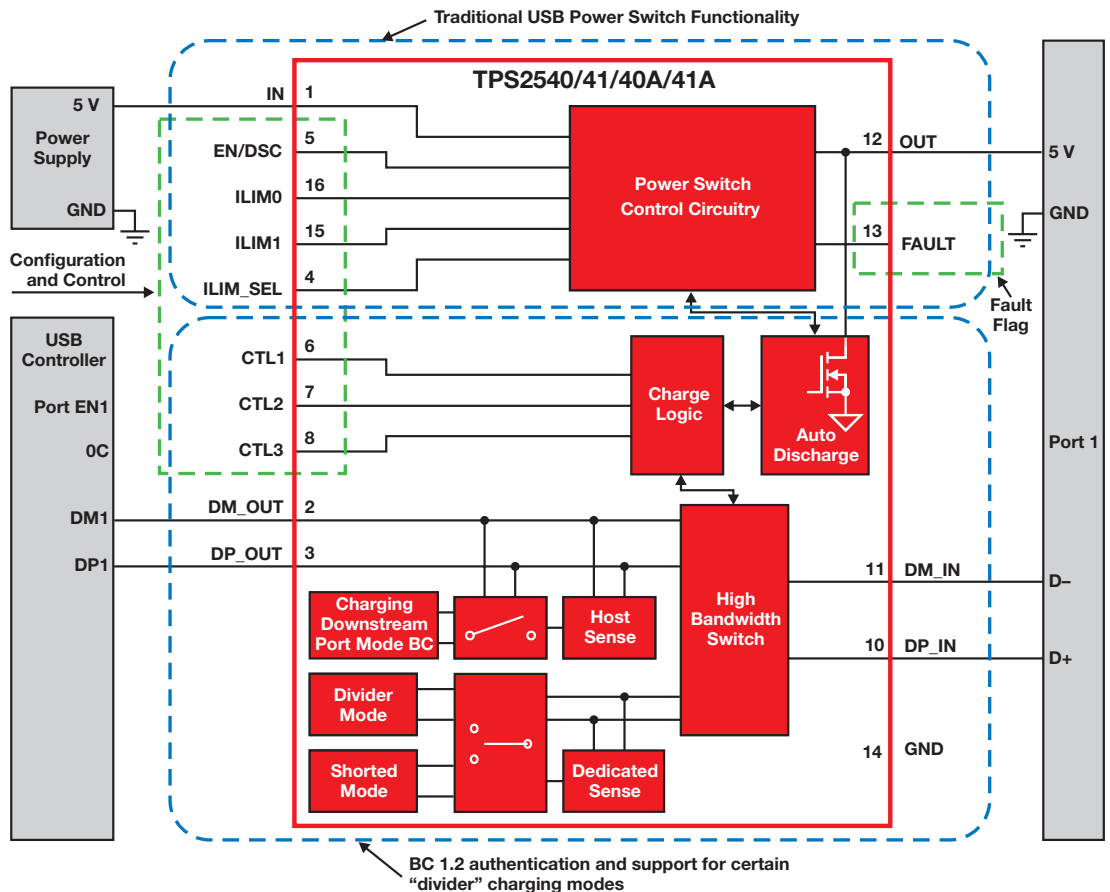

The TPS2540/1 incorporates a traditional USB power switch and the BC 1.2 intelligence for universal charging negotiation.

### TPS2540/1 Comparison

Device	Identical Pinouts	Functionality	Applications Impact	Applications
TPS2540/40A	Pin 5 is EN	Output discharge requires all CTL pins to be low and separate from Enable control.	Discharging voltage on output caps is important during renegotiation. When a power adapter is added or removed, power should be renegotiated.	Notebook PCs or mobile devices.
TPS2541/41A	Pin 5 is DSC	Output discharge functionality and Enable control in one pin, the DSC.	A simple device, like an AC adapter, may not have much I/O available.	Dedicated chargers or anything with I/O constraints.

# Power Protection, Distribution and Monitoring

## USB and Power Switches

### USB Current-Limiting Switches Selection Guide

Device	Number of FETs	I <sub>OS</sub> (min) (A)	R <sub>DS(on)</sub> (mΩ)	V <sub>IN</sub> Range (V)	Supply Current (μA)	OC Logic Output	OT Logic Output	Enable	Predecessor	Price*
TPS2010A	1	0.22	30	2.7 to 5.5	73	No	No	L	TPS2010	0.75
TPS2011A	1	0.66	30	2.7 to 5.5	73	No	No	L	TPS2011	0.75
TPS2012A	1	1.1	30	2.7 to 5.5	73	No	No	L	TPS2012	0.75
TPS2013A	1	1.65	30	2.7 to 5.5	73	No	No	L	TPS2013	0.75
TPS2020/30	1	0.22	33	2.7 to 5.5	73	Yes	Yes	L/H	—	0.90
TPS2021/31	1	0.66	33	2.7 to 5.5	73	Yes	Yes	L/H	TPS2014	0.90
TPS2022/32	1	1.1	33	2.7 to 5.5	73	Yes	Yes	L/H	TPS2015	0.90
TPS2023/33	1	1.65	33	2.7 to 5.5	73	Yes	Yes	L/H	—	0.90
TPS2024/34	1	2.2	33	2.7 to 5.5	73	Yes	Yes	L/H	—	0.90
<b>TPS2052C</b>	2	0.7 ea	70	2.7 to 5.5	50	Yes	Yes	H	TPS2042/52/42A/52A	0.70
TPS2043B/53B	3	0.7 ea	70	2.7 to 5.5	65	Yes	Yes	L/H	TPS2043/53/43A/53A	0.90
TPS2044B/54B	4	0.7 ea	70	2.7 to 5.5	75	Yes	Yes	L/H	TPS2044/54/44A/54A	1.10
TPS2045A/55A	1	0.3	80	2.7 to 5.5	80	Yes	Yes	L/H	TPS2045/55	0.60
TPS2041C/51C	1	.67	96	4.5 to 5.5	60	Yes	Yes	L/H	TPS2051A, TPS2051B	0.45
TPS2061C/65C/65C-2	1	1.3	96	4.5 to 5.5	60	Yes	Yes	L/H/H	TPS2065	0.45
TPS2069C/69C-2	1	1.7	70	4.5 to 5.5	60	Yes	Yes	H/H	TPS2069	0.65
TPS2000C/1C	1	2.35	72	4.5 to 5.5	60	Yes	Yes	L/H	—	0.45
TPS2062C/6C/6C-2	2	1.25 ea	70	4.5 to 5.5	100	Yes	Yes	L/H/H	TPS2062/A, TPS2066/A	0.70
TPS2060C/4C/4C-2	2	1.83 ea	70	4.5 to 5.5	100	Yes	Yes	L/H/H	TPS2060, TPS2064	0.70
<b>TPS2002C/3C</b>	2	2.43 ea	70	4.5 to 5.5	100	Yes	Yes	L/H	—	0.80
TPS2049	1	0.1	400	2.7 to 5.5	43	Yes	Yes	L	TPS2041/51/41A/51A	0.55
TPS2063/7	3	1.1 ea	70	2.7 to 5.5	65	Yes	Yes	L/H	—	0.90
TPS2068/9	1	1.5	70	2.7 to 5.5	43	Yes	Yes	L/H	—	0.75
TPS2080/1/2 <sup>1</sup>	2	0.7 ea	80	2.7 to 5.5	85	Yes	Yes	2H, 1L/1H, 2L	—	0.65
TPS2085/6/7 <sup>1</sup>	4	0.7 ea	80	2.7 to 5.5	85	Yes	Yes	4H, 2L/2H, 4L	—	1.05
TPS2090/1/2 <sup>1</sup>	2	0.3 ea	80	2.7 to 5.5	85	Yes	Yes	2H, 1L/1H, 2L	—	0.65
TPS2095/6/7 <sup>1</sup>	4	0.3 ea	80	2.7 to 5.5	85	Yes	Yes	4H, 2L/2H, 4L	—	1.05
TPS2511	1	0.25 to 2.3	70	4.5 to 5.5	180	No	No	H	—	0.90
TPS2540/A/1/1A/3	1	0.25 to 2.8	73	4.5 to 5.5	150	Yes	Yes	H	—	0.90
TPS2552/53	1	0.75 to 1.3	85	2.5 to 6.5	120	Yes	Yes	L/H	—	0.75
TPS2552-1/53-1	1	0.75 to 1.3	85	2.5 to 6.5	120	Yes	Yes	L/H	—	0.75
TPS2554/55	1	0.25 to 2.8	73	4.5 to 5.5	150	Yes	Yes	H/L	—	0.80
TPS2556/57	1	0.5 to 5	24	2.5 to 6.5	130	Yes	Yes	L/H	—	0.90
TPS2560/61	2	0.25 to 2.5	48	2.5 to 6.5	130	Yes	Yes	L/H	—	0.90

<sup>1</sup>Can be configured as power MUX ICs.

\*Suggested resale price in U.S. dollars in quantities of 1,000.

New devices are listed in bold red. Preview devices are listed in bold teal.

### Internal FET Power Switch Selection Guide

Device	Number of FETs	I <sub>OS</sub> (min) (A)	R <sub>DS(on)</sub> (mΩ)	V <sub>IN</sub> Range (V)	Supply Current (μA)	OC Logic Output	OT Logic Output	Enable	Price*
TPS2590	1	1 to 5	28	3 to 20	35	Yes	No	L	1.05

\*Suggested resale price in U.S. dollars in quantities of 1,000.

# Digital Power Control Solutions

## Complete Isolated Telecom DC/DC PMBus Power Solution

### Digital Power Means Smart Power

For many years, digital communication and processing have been making their way into the power supply. Power-hungry data systems like mobile phone base stations, servers and disk arrays need to increase efficiency and quality of service in smaller form factors while integrating some form of digital capability into the power supply. This digital integration allows designers to make smarter systems where the data traffic and power supply can work together. Below is a typical application example of just such a “smart” power system.

Digital power products range from analog controllers with digital blocks for configuration and telemetry and a digital port for communication, to complex microcontrollers with multiple processors, digital control blocks and multiple communication ports. All of these power solutions perform the required power management but with various degrees of digital integration. The more digital integration there

is, the more you can do with your power supply—in the same or a smaller space.

### Digital Controllers

TI’s digital power controllers include the hardware-optimized, fully programmable UCD3K family of digital controllers for isolated power supplies; the configurable UCD9K family of digital non-isolated point-of-load controllers; and the UCD7K digital-compatible drivers with a programmable current limit. In addition to power-management digital controllers, TI’s fully programmable TMS320F28x MCUs support many power- and energy-related applications, offering versatility and performance.

### Analog Control with PMBus

Power-supply designers who prefer the benefits and familiarity of analog solutions now have the functionality of digital configuration and communication that won’t impact the analog performance. TI offers the TPS404xx family of 20-V step-down voltage regulators with a PMBus-compatible digital interface and an adaptive voltage-scaling capability for

non-isolated point-of-load designs. Together with the high-voltage LM(2)50xx hot-swap system protection and power-management products, TI provides complete single-, dual- and multi-rail, multi-phase PMBus solutions—allowing telecom and server designers to intelligently monitor, protect and manage their power systems.

### Fusion Digital Power™ Designer

The UCD3K and UCD9K families of digital controllers, the LM5066 and LM5064 hot-swap controllers and the TPS40400 and TPS40422 analog PWM controllers are supported by TI’s Fusion Digital Power designer GUI tool. This GUI allows power-supply designers to select compensation networks; configure device parameters such as output voltage and fault-limit values; read back a variety of real-time parameters such as voltage, current, power and temperature; and perform PMBus command, fault and data logging.

Get more information: [www.ti.com/digitalpower](http://www.ti.com/digitalpower)

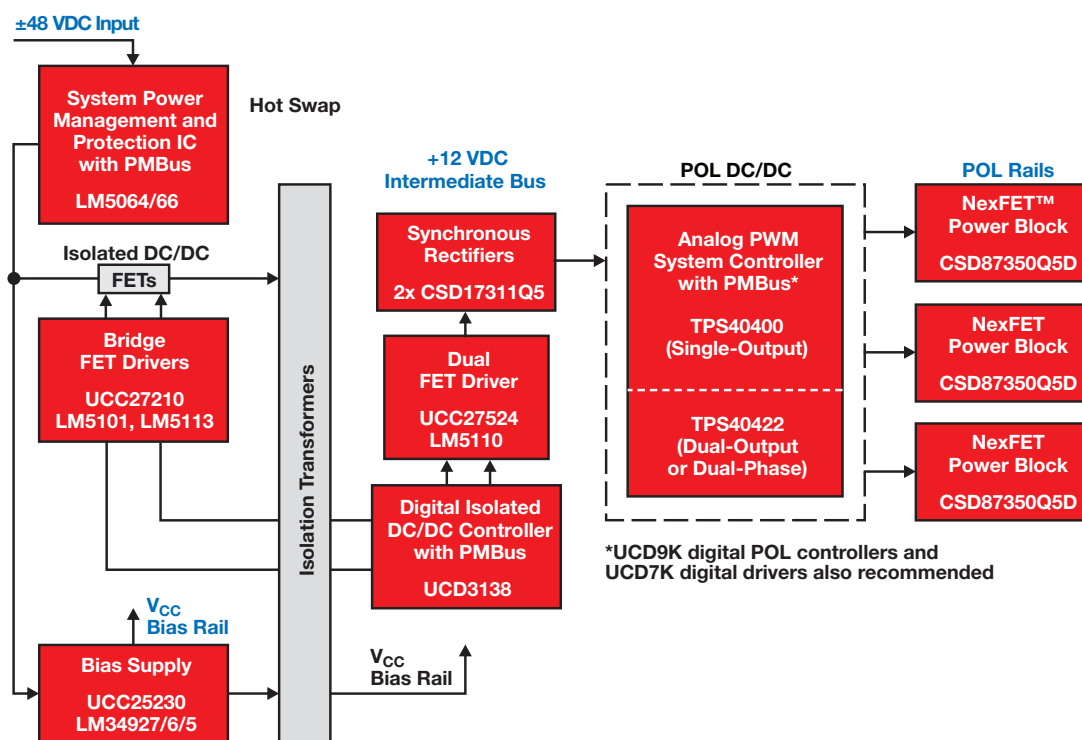

# Digital Power Control Solutions

## Isolated and Non-Isolated Digital Power Controllers

TI focuses on non-isolated (UCD9K) and isolated (UCD3K) PWM digital power controllers, complementary Power Stage solutions (UCD7K), and PTD-series modules. These products are power-management specific and are well-suited for applications that benefit from configurability, communications, diagnostics and adaptive control solutions. They include both isolated and non-isolated solutions from AC line to point-of-load, covering uninterruptible power supplies (UPS), server, telecom and datacom applications. The digital power ICs provide cost-effective solutions with greater levels of performance, reliability and flexibility than today's pure analog designs. For the most up-to-date information on digital power technology and product availability, go to: [www.ti.com/digitalpower](http://www.ti.com/digitalpower)

### Key Benefits

- High levels of integration:
  - Multiple outputs and phases with a single controller
  - Integrated supply-voltage sequencing, monitoring and margining
  - Improved reliability with fewer parts
- Advanced functionality:
  - Real-time power monitoring, data logging and failure prediction
  - Flexible control for varying operation modes and load characteristics
  - Calibration in manufacturing
- System optimization:
  - Easily set fault limits, start characteristics after system is assembled
  - Enhanced phase management
- Full programmability (UCD3K)

### Digital Solution Features

- PMBus Version 1.1
- Power + Designer Graphical User Interface tool
- Programmable soft-start/stop configuration
- Voltage sequencing and tracking
- Voltage margining and monitoring
- Pre-biased, monotonic start-up
- Multiple levels of fault protection with selectable response
- Hardware-accelerated digital compensator
- Load sharing on multiphase power stages
- Frequency synchronization
- Digital monitoring of power-supply parameters

### UCD9K Buck Controllers

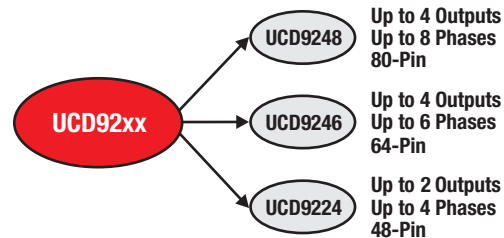

### UCD3K Isolated Power Controllers

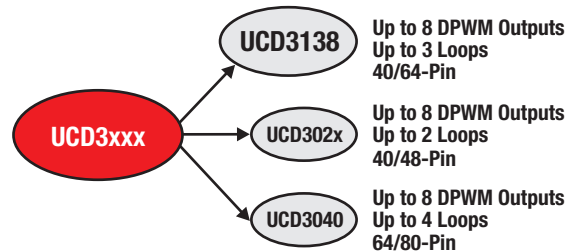

### Digital Power Stage Solutions

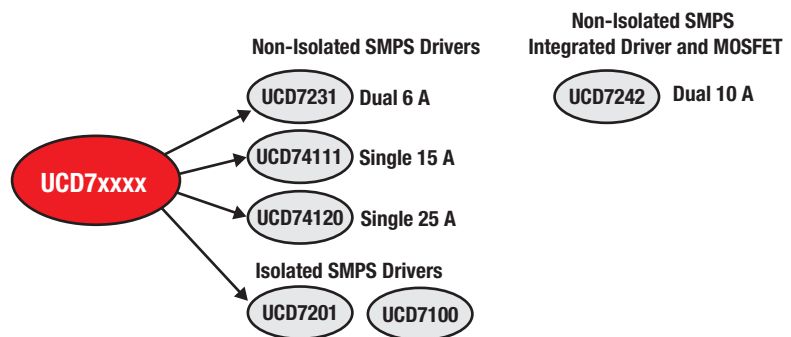

### Non-Isolated Digital Power-Train Modules

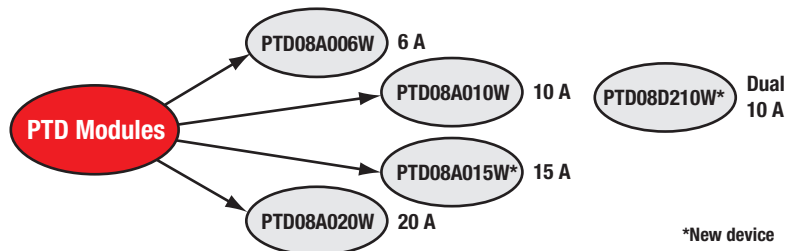



# Digital Power Control Solutions

## Isolated and Non-Isolated Digital Power Controllers

### Digital Point-of-Load Controller

#### UCD9248

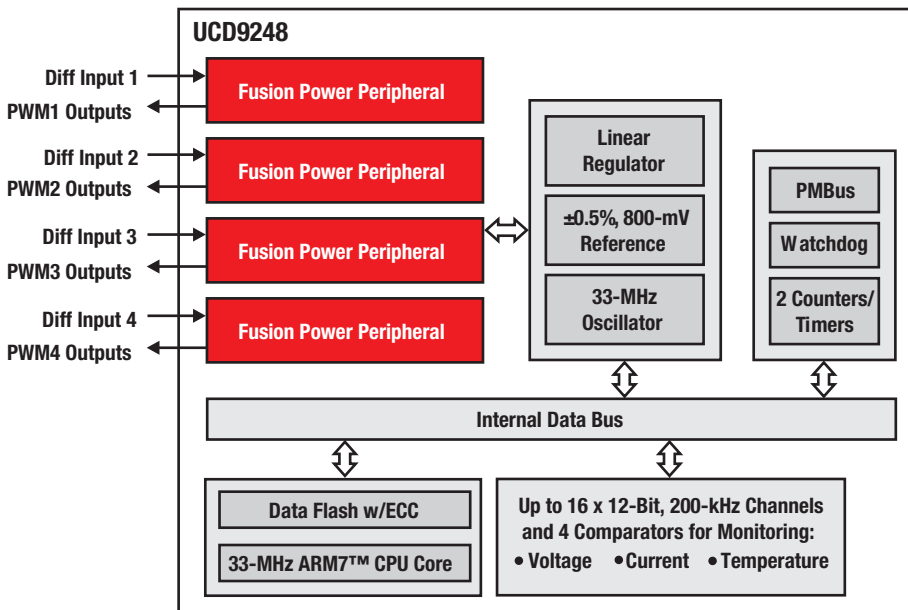

UCD9248 controller overview.

#### Key Features

- Controls up to 8 power stages and up to 4 voltage-feedback control loops
- Output voltage is configurable from 0.4 to 4.0 V
- Flexible configuration to control:
  - Four single or two dual power stages,
  - Two 4-phase power stages, or
  - One 2-, 4-, 6- or 8-phase power stage
- Switching frequencies of up to 2 MHz
- Supports conversion ratio of 12:1 at 2 MHz with 250-ps duty-cycle resolution
- ±1-mV feedback resolution
- Hardware-accelerated, digital 3-pole/3-zero compensator
- Can synchronize PWM clocks between multiple UCD9248 devices

Get more information: [www.ti.com/product/UCD9248](http://www.ti.com/product/UCD9248)

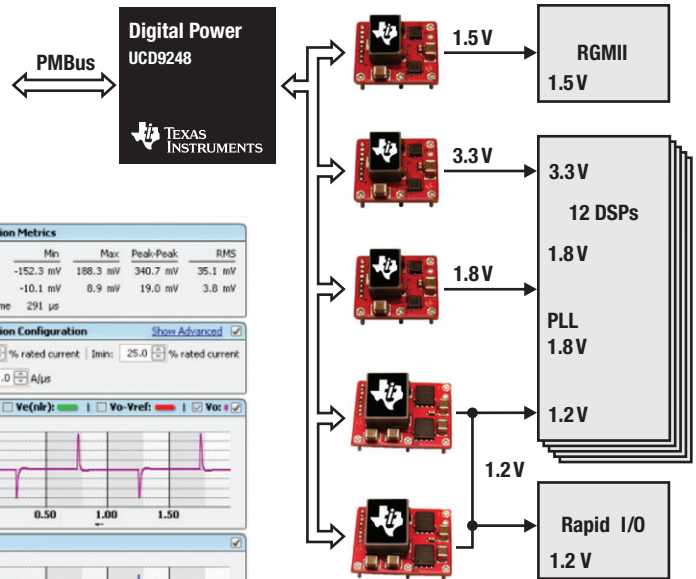

### Fusion Digital Power™ Designer

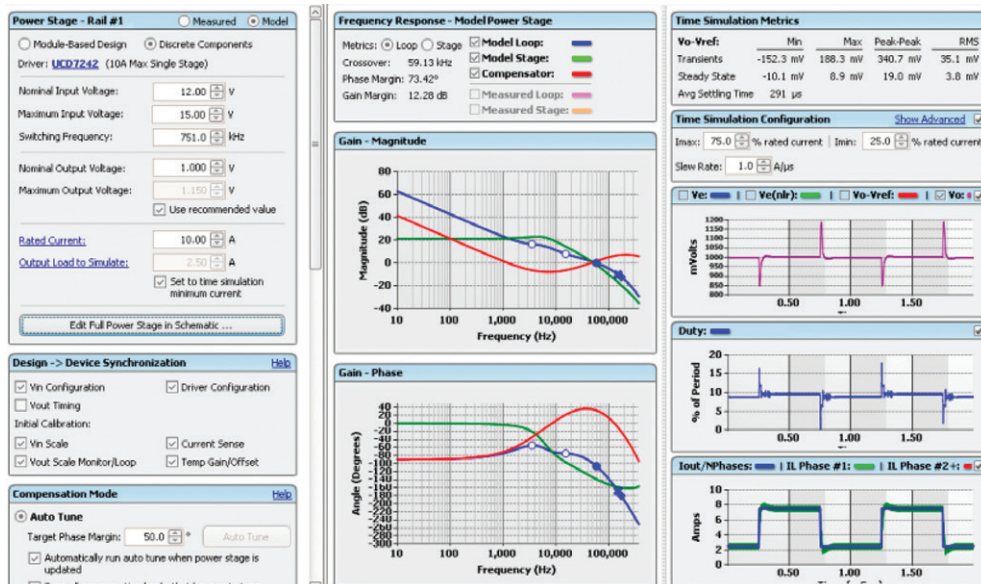

Graphical user interface (GUI) Digital Power developer tool simplifies the design process.

Multiprocessor, multiple-supply-rail systems (three single-phase outputs and one dual-phase output) featuring UCD9248 and first-generation PTD modules.

# Digital Power Control Solutions

## Isolated and Non-Isolated Digital Power Controllers

### Isolated Digital Power-Control Solutions

#### UCD3138

The UCD3138 is a highly integrated and configurable digital-power-management controller that is optimized for AC/DC and isolated DC/DC power-supply applications. The device offers an innovative path to increase power density and reliability in a broad range of power-supply topologies used in servers, telecom rectifiers and high-power DC/DC modules. Digital control capabilities allow designers to do more with their power systems, including reuse of hardware designs across multiple platforms. Designers also have the versatility to fine-tune the performance and control parameters for each application, thus allowing faster time to market. The UCD3138 combines a powerful 32-bit microprocessor, high-speed precision data converters, multiple programmable hardware control loops and various communication engines in a small 6x6-mm package.

#### Key Features

- Digital control—Three voltage or current feedback loops with up to six high-resolution digital pulse-width-modulated (DPWM) outputs.
- Boosted peak- and light-load efficiency—Includes sync-FET soft on-off control, dynamic phase shedding, dynamic frequency adjustment and dynamic mode switching.
- Supports all isolated power-supply topologies—Controller support for single-phase, two-phase interleaved, or bridgeless power factor correction; hard-switching full-bridge, phase-shifted full-bridge, resonant LLC and other topologies.
- Integrates all essential protection features—Included functions are peak current-mode control, cycle-by-cycle peak-current limiting, high-speed input voltage feed-forward, overvoltage, overcurrent and overtemperature protection.

#### Easy-to-Use GUI and Development Tools

Designers will have easy access to several digital-power development tools such as full-voltage and feature-rich evaluation modules, development kits, reference designs, application firmware source code, programmer's manuals and the Code Composer Studio™ software development environment. TI's Fusion Digital Power™ Designer graphical user interface (GUI) software tool provides flexible configuration of key power parameters, as well as telemetry, logging and communication functions. A broad range of hardware design tools, such as control-card and open-loop evaluation modules, are available to select customers. In addition, TI offers easy-to-use development kits and reference designs.

#### Evaluation Modules

- UCD3138CC64EVM-030 control card
- UCD3138OL64EVM-031—UCD3138 64-pin, open-loop board with socket
- UCD3138OL40EVM-032—UCD3138 40-pin, open-loop board with socket

- UCD3138NS64EVM-038—UCD3138 64-pin, open-loop board with IC soldered
- UCD3138NS40EVM-039—UCD3138 40-pin, open-loop board with IC soldered

#### Development Kits

- UCD3138PFCEVM-026—Universal-input, 400-V<sub>OUT</sub>, AC/DC PFC development kit that is configurable into single- or two-phase interleaved and bridgeless topologies
- UCD3138PSFBEVM-027—400-V<sub>IN</sub>/12-V<sub>OUT</sub> DC/DC phase-shifted full bridge
- UCD3138LLCEVM-028—400-V<sub>IN</sub>/12-V<sub>OUT</sub> DC/DC half-bridge resonant LLC
- UCD3138HSFBEVM-029—48-V<sub>IN</sub>/12-V<sub>OUT</sub> DC/DC hard-switching full-bridge

#### Reference Designs

- Universal-input, 12-V<sub>OUT</sub> 500-W AC/DC reference design (PFC plus LLC and PFC plus phase-shifted full-bridge)
- 48-V<sub>IN</sub>/12-V<sub>OUT</sub> 1/8-brick DC/DC reference design (hard-switching full bridge)

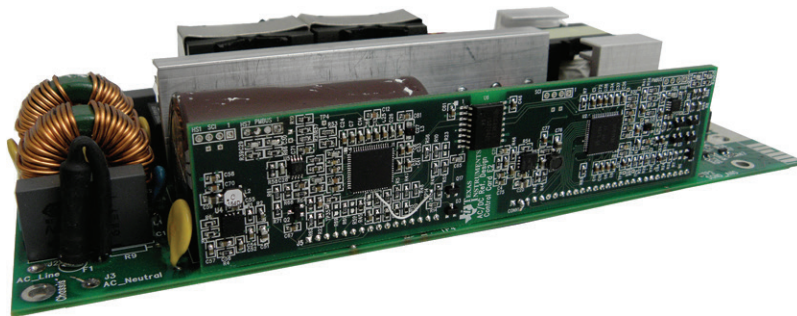

500-W AC/DC power supply reference design.

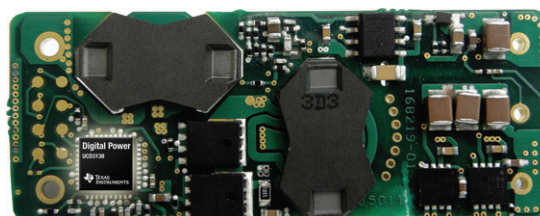

250-W 1/8th brick module reference design.

Get more information: [www.ti.com/product/UCD3138](http://www.ti.com/product/UCD3138)

# Digital Power Control Solutions

## Isolated and Non-Isolated Digital Power Controllers

### Selection Guide

Device	Pin Count	Number of Outputs	Number of Phases	Maximum F <sub>SW</sub> (MHz)	PWM Resolution (ps)	Compensator	Nonvolatile Memory	Price*
<b>Digital Point-of-Load Controllers</b>								
UCD9222/44 <sup>1</sup>	48/64	2/4	1	2	250	3-pole/3-zero	3-pole/3-zero	3.15/5.85
UCD9224	48	2	4	2	250	3-pole/3-zero	3-pole/3-zero	2.65
UCD9248/6	80/64	4	8/6	2	250	3-pole/3-zero	Yes w/ECC	4.85/4.50

<sup>1</sup>UCD9222 and UCD9244 digital PWM controllers with support for TMS320C6670 and TMS320C6678 DSPs VID interface.

\*Suggested resale price in U.S. dollars in quantities of 1,000.

Device	Number of Outputs	Output Configuration	Output Type <sup>1</sup>	Peak I <sub>OUT</sub> Source/Sink (A)	Rise/Fall Time (ns)	V <sub>CC</sub> Range (V)	Propagation Delay (ns)	Input Threshold	Dead-Time Control	Protection Features	Price*
<b>Digital Power MOSFET Drivers</b>											
UCD7231	2	Non-inverting	CMOS	6/6	10/10	4.5 to 15.5	25	CMOS/TTL	Adaptive	Adjustable	0.60
UCD7232	2	Non-inverting	CMOS	6/6	10/10	4.5 to 15.5	25	CMOS/TTL	Adaptive	Adjustable	0.60
UCD7100	1	Uncommitted/Non-inverting	TrueDrive™	4/4	10/10	4.5 to 16	20	CMOS/TTL	Adaptive	Adjustable	0.99
UCD7201	2	Uncommitted/Non-inverting	TrueDrive	4/4	10/10	4.5 to 16	20	CMOS/TTL	Adaptive	Adjustable	1.20

<sup>1</sup>Output type: TrueDrive is the hybrid bipolar/CMOS output architecture for improved current drive capability at low voltages (at Miller threshold).

\*Suggested resale price in U.S. dollars in quantities of 1,000.

Device	Pin Count	Number of DPWM Outputs	Number of Independent Control Loops	DPWM Resolution (ps)	DPWM Maximum Frequency (MHz)	Program Flash Memory Size (KB)	Number of 12-Bit ADC Channels	Compensator	Price*
<b>Digital Isolated Power Controllers</b>									
UCD3020	48	6	2	250	2	32	9	3-pole/3-zero	2.45
UCD3028	40	8	2	250	2	32	9	3-pole/3-zero	2.35
UCD3040	64/80	8	4	250	2	32	11/15	3-pole/3-zero	3.75/4.05
UCD3138	40/64	8	3	250	2	32	7/14	2-pole/2-zero	2.70/4.10

\*Suggested resale price in U.S. dollars in quantities of 1,000.

Device	Input Voltage (V)	Output Configuration	Current Rating (A)	Price*
<b>Digital Power Stages</b>				
UCD7242	4.5 to 18	Dual	10/10	2.65
UCD74106	4.5 to 14	Single	6	1.00
<b>UCD74111</b>	4.5 to 14	Single	15	2.95
<b>UCD74120</b>	4.5 to 14	Single	25	3.95

Device	Input Voltage (V)	Output Configuration	Current Rating (A)	Price*
<b>Digital Power-Train Modules</b>				
PTD08A006W	4.75 to 14	Single	6	6.90
PTD08A010W	4.75 to 14	Single	10	8.50
PTD08A015W	4.75 to 14	Single	15	9.80
PTD08A020W	4.75 to 14	Single	20	12.90
PTD08D210W	4.75 to 14	Dual	10/10	9.25
PTD08A210W	4.75 to 14	Single	10	7.50

\*Suggested resale price in U.S. dollars in quantities of 1,000.

*New devices are listed in bold red.*

# Supervisors and Reset ICs

## Supervisory Circuits, Reset ICs and Sequencers Family of Products

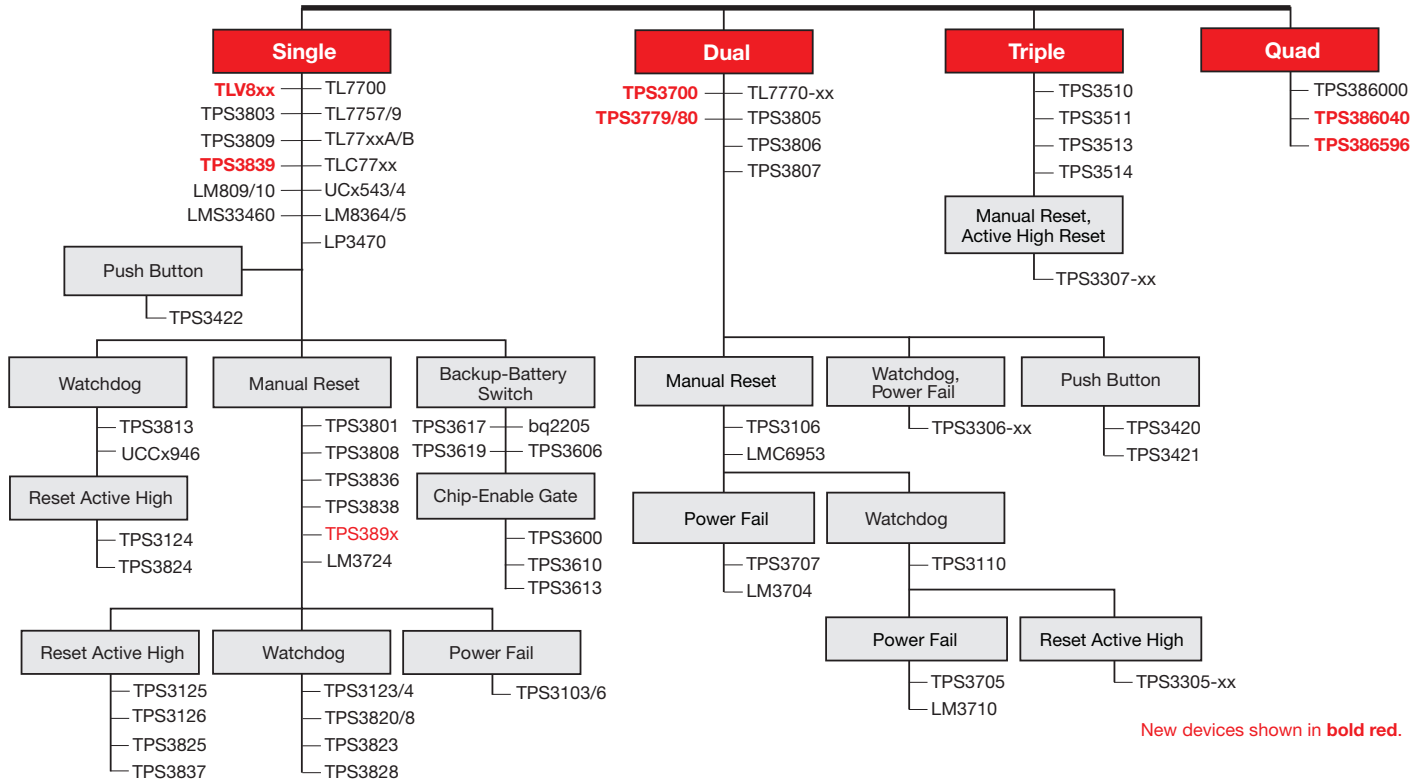

For more information, please visit: [www.ti.com/supervisors](http://www.ti.com/supervisors)

## Window Comparator for Over- and Under-Voltage Detection

### TPS3700

**NEW**

#### Features

- Wide supply range: 1.8 to 18 V
- High accuracy threshold: 1% (over temperature range)
- Open drain OV and UV output
- Available in TSOT23-6 package

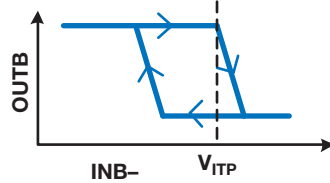
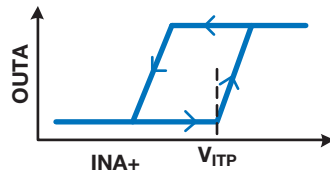
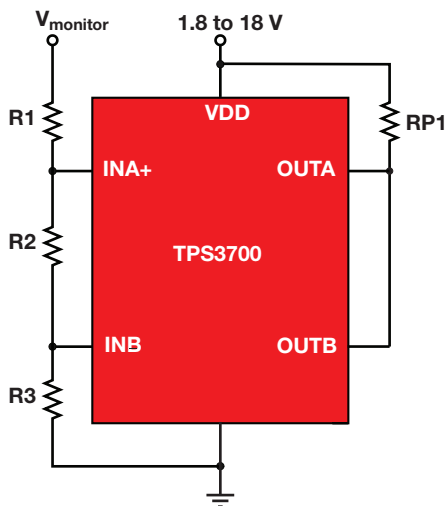

DDC PACKAGE  
ThinSOT23-6  
(TOP VIEW)

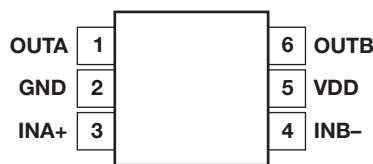

Get more information: [www.ti.com/product/TPS3700](http://www.ti.com/product/TPS3700)

# Supervisors and Reset ICs

## Selection Guide

Device	Number of Supervisors	Supervised Voltages	Package(s)	V <sub>DD</sub> Range (V)	I <sub>DD</sub> (typ) (µA)	Time Delay (ms)	Watchdog Timer WDI (sec)	Reset Threshold Accuracy (%)	Manual Reset/Enable Reset	Active-Low Reset/Output	Active-High Reset/Output	Reset Output Topology <sup>1</sup>	Power-Fail PFI/PFO	Overvoltage Detection	Overcurrent Detection	Chip-Enabled Gating	Comments	Price*
<b>General Purpose Supply Supervisors</b>																		
LM3724	1	2.32, 3.08, 4.63	SOT23-5, D, W	1 to 6	6	0.02		±2.5	✓	✓		OD	✓					0.95/0.80
LP3470	1	2.63, 2.75, 2.83, 2.93, 3.08, 3.65, 4.0, 4.38, 4.63, 4.8	SOT23-5	0.5 to 5	16	0.3		±1		✓		OD						0.595/0.562
LM3704	2	2.32, 3.08, 3.6	micro SMD-9, MSOP-10	1 to 5.5	28	0.02		±2	✓	✓		CMOS, OD	✓					0.77
LM3710	2	2.32, 3.08, 4.63	MINI SOIC	1 to 5.5	28	0.02	0.0062 to 25.6	±2	✓	✓		CMOS, OD	✓					1.10
LM8364	1	2.0	SOT23-5	1 to 6	0.65	0.3		±2.5		✓		CMOS, OD						0.239
LM8365	1	2.75, 4.5	SOT23-5	1 to 6	0.65	0.1		±2.5		✓		CMOS, OD						0.249
LM809	1	2.63, 2.93, 3.08, 4.38, 4.63	SOT23-3, LLP-6, D, W	1 to 6	15	0.02		±1.5		✓		CMOS						0.229
LM810	1	4.63	SOT23-3, D, W	1 to 6	15	0.02		±1.5			✓	CMOS						0.229
LMS33460	1	3	SC-70	1 to 7	1	0.2		±5		✓		OD						0.169
LMC6953	2	3.3, 3.5	SOIC-8	1.5 to 6	800	0.0005		±3	✓	✓		OD						1.44
TPS3895	1	Adj.	SON-6	1.7 to 6.5	6	0.04, Prog	—	0.25	✓	✓	✓	PP					Ultra-small	0.60
TPS3896	1	Adj.	SON-6	1.7 to 6.5	6	0.04, Prog	—	0.25	✓	✓	✓	PP					Ultra-small	0.60
TPS3897	1	Adj.	SON-6	1.7 to 6.5	6	0.04, Prog	—	0.25	✓		✓	OD					Ultra-small	0.60
TPS3898	1	Adj.	SON-6	1.7 to 6.5	6	0.04, Prog	—	0.25	✓	✓		OD					Ultra-small	0.60
TLV803	1	2.5/3/3.3/5	3SOT-23	1.1 to 6	9	200	—	2.00		✓		OD						0.20
TLV810	1	2.5/3/3.3/5	3SOT-23	1.1 to 6	9	200	—	2.00			✓	PP						0.20
TPS3808	1	Adj./0.9/1.2/1.5/1.8/2.5/3.0/3.3/5.0/EEPROM	SOT-23, SON-6	1.8 to 6.5	2.4	Prog	—	0.5	✓	✓		OD						0.70
TPS3103	1	1.2/1.5/2.0/3.3	SOT-23	0.4 to 3.3	1.2	130	—	0.75	✓	✓		OD	✓					0.90
TPS3123	1	1.2/1.5/1.8	SOT-23	0.75 to 3.3	14	180	1.4	3.6	✓	✓		PP						0.85
TPS3124	1	1.2/1.5/1.8	SOT-23	0.75 to 3.3	14	180	1.4	3.6		✓	✓	PP						0.85
TPS3125	1	1.2/1.5/1.8/3.0	SOT-23	0.75 to 3.3	14	180	—	3.6	✓	✓	✓	PP						0.80
TPS3126	1	1.2/1.5/1.8	SOT-23	0.75 to 3.3	14	180	—	3.5	✓	✓	✓	OD						0.80
TPS3128	1	1.2/1.5/1.8	SOT-23	0.75 to 3.3	14	180	1.4	3.5	✓	✓		OD						0.85
TPS3800	1	2.7	SC-70	1.6 to 6.0	9	100	—	2	✓	✓		PP						0.40
TPS3801	1	Adj./1.8/2.5/3.0/3.3/5.0	SC-70	1.6 to 6.0	9	200	—	2	✓	✓		PP						0.40
TPS3802	1	3.0/3.3	SC-70	1.6 to 6.0	9	400	—	2	✓	✓		PP						0.40
TPS3803	1	Adj./1.5	SC-70	1.3 to 6.0	3	—	—	1.5		✓		OD					Voltage detector	0.25
TLV809	1	2.5/3.0/3.3/5.0	SOT-23	2.0 to 6.0	9	200	—	2.2		✓		PP						0.25
TPS3813	1	2.5/3.0/3.3/5.0	SOT-23	2.0 to 6.0	9	25	Window	2.2		✓		OD					Window watchdog	0.90
TPS3820/8-xx	1	3.3/5.0	SOT-23	1.1 to 5.5	15	25/200	0.2/1.6	2.4	✓	✓		PP/OD						0.65
TPS3823	1	2.5/3.0/3.3/5.0	SOT-23	1.1 to 5.5	15	200	1.6	2.4	✓	✓		PP						0.65
TPS3824-xx	1	2.5/3.0/3.3/5.0	SOT-23	1.1 to 5.5	15	200	1.6	2.2	✓	✓	✓	PP						0.65
TPS3825-xx	1	3.3/5.0	SOT-23	1.1 to 5.5	15	200	—	2.2	✓	✓	✓	PP						0.55
TPS3836/8	1	1.8/2.5/3.0/3.3	SOT-23	1.6 to 6.0	0.22	10/200	—	2.5	✓	✓		PP/OD						0.85
TPS3837	1	1.8/2.5/3.0/3.3	SOT-23	1.6 to 6.0	0.22	10/200	—	2.4	✓		✓	PP						0.85
TLC77xx	1	Adj./2.5/3.3/3.0/5.0	SO-8, DIP-8, TSSOP-8	2.0 to 6.0	9	Prog	—	5.5		✓	✓	PP						0.65
TPS3807	2	3/3.5	SC-70	1.8 to 6.5	3.5	20	—	1		✓		OD						0.95
TPS3106	2	Adj./0.9/1.6/3.3	SOT-23	0.4 to 3.3	1.2	130	—	0.75	✓	✓		OD						0.90
TPS3110	2	Adj./0.9/1.2/1.5/3.3	SOT-23	0.4 to 3.3	1.2	130	1.1	0.75	✓	✓		PP						0.99
TPS3305-xx	2	1.8/2.5/3.3/5.0	SO-8, MSOP-8	2.7 to 6.0	15	200	1.6	2.7	✓	✓	✓	PP						1.00
TPS3306-xx	2	1.5/1.8/2.0/2.5/3.3/5.0	SO-8, MSOP-8	2.7 to 6.0	15	100	0.8	2.7		✓		OD	✓					1.05
TPS3700	2	Adj.	ThinSOT23-6	1.8 to 18	5.5	—	—	0.25		✓	✓	OD					Window comparator	0.70
TPS3705-xx	2	3.0/3.3/5.0	SO-8, MSOP-8	2.0 to 6.0	30	200	1.6	2.1	✓	✓		PP	✓					0.80
TPS3707-xx	2	2.5/3.0/3.3/5.0	SO-8, MSOP-8	2.0 to 6.0	20	200	—	2.2	✓	✓	✓	PP	✓					0.75
TPS3805	2	Adj./3.3	SC-70	1.3 to 6.0	3	—	—	1.5		✓		PP					Voltage detector	0.34

<sup>1</sup>PP = push-pull, OD = open drain, OC = open collector.  
\*Suggested resale price in U.S. dollars in quantities of 1,000.

Note: Custom voltages can be provided. Minimum order quantities may apply. Contact TI for details and availability.

New devices are listed in bold red.

# Supervisors and Reset ICs

## Selection Guide (Continued)

Device	Number of Supervisors	Supervised Voltages	Package(s)	V <sub>DD</sub> Range (V)	I <sub>DD</sub> (typ) (μA)	Time Delay (ms)	Watchdog Timer WDI (sec)	Reset Threshold Accuracy (%)	Manual Reset/Enable Reset	Active-Low Reset/Output	Active-High Reset/Output	Reset Output Topology <sup>1</sup>	Power-Fail PFI/PFO	Overvoltage Detection	Overcurrent Detection	Chip-Enabled Gating	Comments	Price*
<b>General Purpose Supply Supervisors (Continued)</b>																		
TPS3806	2	Adj./2.0/3.3	SOT-23	1.3 to 6.0	3	—	—	2		✓		OD					Voltage detector	0.45
TPS3307-xx	3	Adj./1.8/2.5/3.3/5.0	SO-8, MSOP-8	2.0 to 6.0	15	200	—	2.7	✓	✓	✓	PP						1.05
<b>TPS386596</b>	4	Adj./3.0	MSOP-8	1.8 to 6.5	7.5	Prog	—	0.25	✓	✓		OD		✓				1.25
TPS3860x0	4	Adj. (includes negative rail)	QFN	1.8 to 6.5	9	Prog	0.6	0.25	✓	✓	✓	PP/OD		✓				1.95
<b>Battery Backup Switchover Supply Supervisors</b>																		
TPS3600	1	2.0/2.5/3.3/5.0	TSSOP-14	1.6 to 5.5	20	100	0.8	2.3	✓	✓		PP	✓			✓		2.15
TPS3606-33	1	3.3	MSOP-10	1.6 to 5.5	20	100	0.8	2	✓	✓		PP	✓					1.45
TPS3610	1	1.8/5.0	TSSOP-14	1.6 to 5.5	20	100	0.8	2		✓		PP	✓			✓		1.80
TPS3613-01	1	Adjustable	MSOP-10	1.6 to 5.5	20	100	—	1.7	✓	✓	✓	PP				✓		1.50
TPS3619	1	3.3/5.0	MSOP-8	1.6 to 5.5	15	100	—	2	✓	✓		PP	✓					1.10
<b>Special Function Supply Supervisors</b>																		
TPS3510/1	3	3.3/5.0/12.0	SO-8, DIP-8	4 to 15	1 mA	300	—	9.1		✓		OD	✓	✓			PC power supplies	0.45
TPS3513/4	3	3.3/5.0/12.0	SO-14, DIP-14	4.5 to 15	1 mA	300	—	9.1		✓		OD	✓	✓	✓		PC power supplies	0.70

<sup>1</sup>PP = push-pull, OD = open drain, OC = open collector.

\*Suggested resale price in U.S. dollars in quantities of 1,000.

Note: Custom voltages can be provided. Minimum order quantities may apply. Contact TI for details and availability.

New devices are listed in bold red.

## Sequencers

### Selection Guide

Device	Number of Supervisors	Supervised Voltages	Number of Sequenced Outputs	Package(s)	V <sub>DD</sub> Range (V)	I <sub>DD</sub> (typ) (μA)	Time Delay (ms)	Comments	Price*
LM3880	—	—	3	SOT23-6	2.7 to 5.5	25	Fixed		0.50
LM3881	—	—	3	MSOP-8	2.7 to 5.5	80	Prog		0.50
UCD9090	10	Prog. by software GUI	—	QFN-64	3.3 to 12	50 mA	Prog		3.60
UCD90120A	13	Prog. by software GUI	—	QFN-64	3.3 to 12	50 mA	Prog		4.95
UCD90124A	13	Prog. by software GUI	—	QFN-64	3.3 to 12	50 mA	Prog	With fan control	6.45
UCD90160	16	Prog. by software GUI	—	QFN-64	3.3 to 12	50 mA	Prog		5.65
UCD90910	10	Prog. by software GUI	—	QFN-64	3.3 to 12	50 mA	Prog	With fan control	5.90

\*Suggested resale price in U.S. dollars in quantities of 1,000.

# Push Button Controllers

## Single and Dual Push-Button Controllers

### TPS3420, TPS3421, TPS3422

TPS342x family of devices provide the ability to perform a hardware system reset during a software crash. It also eliminates the need to remove batteries to activate a reset. These controllers are used in designs with an embedded battery to ensure a hard- and full-system reset when needed. They include a fail-safe option when the system/microprocessor freezes and a system reset is required. Holding one or two external button switches for x amount of seconds generates a reset. To improve system stability, short-period switch closures are rejected by the setup delay time ( $t_{setup}$ ), as shown in the timing diagram.

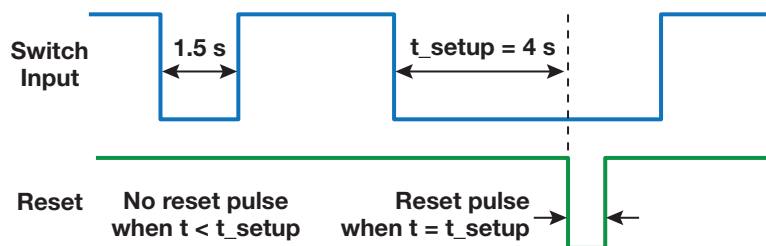

### Key Features

- Very small, 1.45x1-mm SON package
- Low supply current: 250 nA
- User-selectable input delay using two-state logic
- Fixed-pulse or input-dependent reset behavior

### Applications

- Smart phones
- Tablets
- Ultrabooks
- Notebooks
- Routers
- Consumer medical

Get more information: [www.ti.com/product/TPS3420D](http://www.ti.com/product/TPS3420D), [TPS3421EC](http://www.ti.com/product/TPS3421EC) or [TPS3422EG](http://www.ti.com/product/TPS3422EG)

# Current Power Monitors

## Selection Guide

Device	Description	Common-Mode Range		Gain (V/V)	Output Type	Input Offset (+/-)(max) ( $\mu$ V)	CMRR (min) (dB)	Quiescent Current (+/-)(typ) (mA)	$V_s$		Package(s)	Price*
		(min)	(max)						(min) (V)	(max) (V)		
INA226	High-side measurement, bi-directional current power monitor with $I^2C$ interface	0	36	1	$I^2C$	10	126	0.33	2.7	5.5	MSOP-10	1.30
INA210	Voltage output, high/low-side measurement, bi-directional zero-drift series current power monitor	-0.3	26	200	Voltage	35	105	0.065	2.7	26	$\mu$ QFN-10, SC70-6	0.65
INA219	Zero-drift, bi-directional current power monitor	0	26	Programmable	$I^2C$	50	100	0.7	3	5.5	SOIC-8, SOT-23-8	0.80
INA230	Precision digital/current/voltage/power monitor	0	28	1	$I^2C$	50	100	330	2.7	5.5	QFN-16	1.15
INA282	Wide common mode range, bidirectional, high accuracy current power monitor	-14	80	50	Voltage	70	120	0.6	2.7	18	SOIC-8	1.25
LMP8640	Precision high-voltage current sense amplifier	-2	76	20, 50, 100	Voltage	900	60	0.72	2.7	12	SOT-6	0.89
LMP8645	Precision high-voltage current sense amplifier	-2	76	Programmable	Voltage	1000	60	0.61	2.7	12	SOT-6	0.89
LMP8646	Precision current limiter	-2	76	Programmable	Voltage	1000	95	0.38	2.7	12	SOT-6	1.20

\*Suggested resale price in U.S. dollars in quantities of 1,000.

# DDR Power Solutions

## TI DDR Power Application

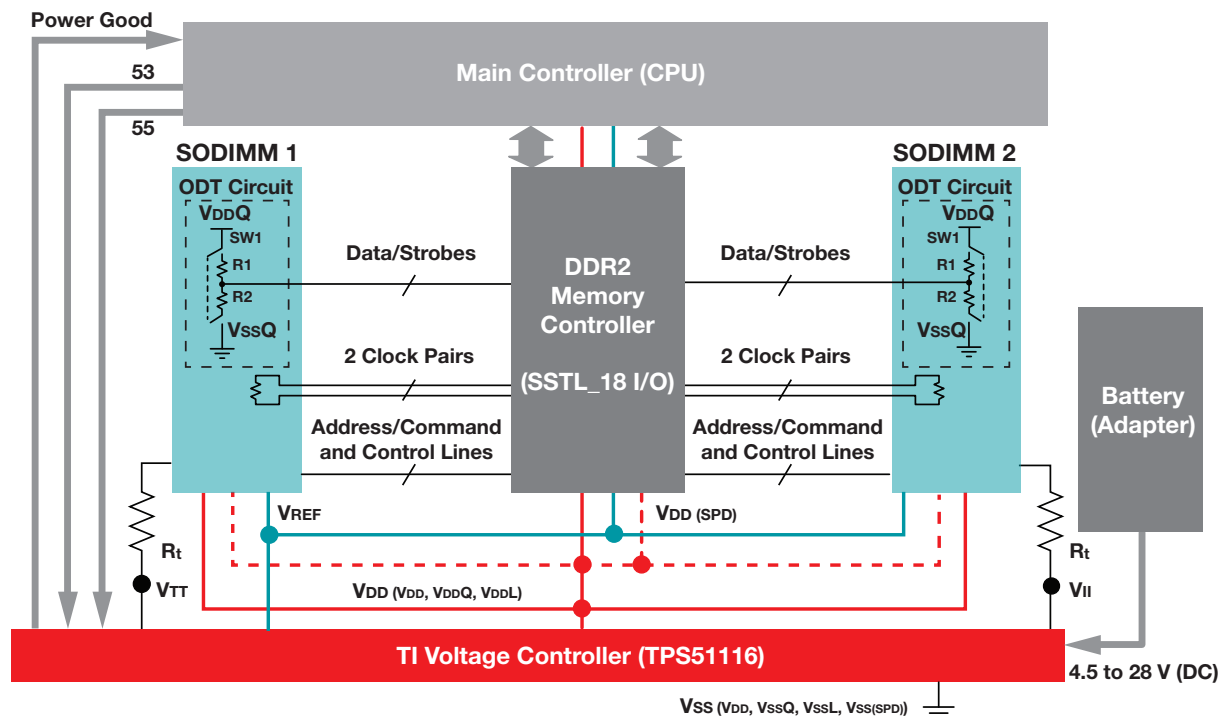

## Selection Guide

Device	V <sub>IN</sub> (V)	I <sub>OUT</sub> (A)	Provides	DDR Type
<b>Plug-in Modules</b>				
PTH03010/50/60W	2.95 to 3.65	6/10/15	VTT	1, 2, 3
PTH05010/50/60W	4.5 to 5.5	6/10/15	VTT	1, 2, 3
PTH12010/50/60L	10.8 to 13.2	6/10/12	VTT	1, 2, 3
<b>Controllers</b>				
TPS40042	2.25 to 5.5	Up to 15	VTT	1, 2, 3
TPS40057	8 to 40	Up to 20	VTT	1, 2, 3
<b>Controller + LDO</b>				
TPS51116, TPS51216/716/916	3 to 28 <sup>1</sup>	Up to 25 A for VDDQ, 3 (2-A VTT for TPS51216/916)	VTT, VDDQ, VREF	1, 2, 3, LV3, LP3
<b>Dual Controller</b>				
TPS51020	4.5 to 28	Up to 15	VTT, VDDQ, VREF	1, 2
<b>LDOs</b>				
TPS51100	1.2 to 3.6 <sup>2</sup>	Up to 3	VTT, VREF	1, 2, 3, LV3, LP3
TPS51200	1.1 to 3.5 <sup>3</sup>	Up to 3	VTT, VREF	1, 2, 3, LV3, LP3
TPS51206	VTT+0.4 V to 3.5 V	Up to 2	VTT, VREF	1, 2, 3, LV3, LP4
<b>Switchers with Integrated FETs</b>				
TPS54372	3 to 6	3	VTT	1, 2, 3
TPS53317, TPS54672	3 to 6	6	VTT	1, 2, 3, LV3, LP3
TPS54972	3 to 4	9	VTT	1, 2, 3
TPS51362/7	3 to 22 <sup>1</sup>	10/12	VDDQ	1,2,3, LV3, LP3

<sup>1</sup>Needs 4.5- to 5.5-V bias.

<sup>2</sup>Needs 4.75- to 5.25-V bias.

<sup>3</sup>Needs 2.4- to 3.5-V bias.



### PowerLab™ Power Reference Design Library

The PowerLab library includes an interactive and powerful search engine for design engineers looking for a proven and tested solution to their power-supply requirements. This interactive search tool allows engineers to find designs by application, topology, input type, input voltage or output voltage.

#### Features

- Extensive collection of tested power-management reference designs
- Hundreds of power-management designs for a wide range of applications and power-conversion topologies
- Reference designs include both isolated and non-isolated designs for lighting, telecommunication, computing, consumer electronics and more

Get more information:  
[www.ti.com/powerlab](http://www.ti.com/powerlab) or  
[www.ti.com/webench](http://www.ti.com/webench)

PowerLab™ Power Reference Designs Selection Tool

Design	Title	Input Voltage Range (Min)	Input Voltage Range (Max)
PMP1090	Sync Buck for MFP (5V @ 2A, 3.3V @ 2A)	22	26
PMP1129	Flyback for Automotive (16V @ 5A)	8	36
PMP1143	Isolated Flyback for Router Gate Wa	85	265
PMP1171	Sync Buck (3.3V @ 2A, 1.2V @ 6.5A)	11	24
PMP1281	Boost (-12V @ 300mA)	11	13
PMP1307	Buck, boost (7.5V @ .5A, 8.5V @ 1.5A)	6	60
PMP1329	SEPIC for Alarm System (3.6V @ 3A)	2.7	9
PMP1353	Boost for Telecom (48V @ 2A)	10.8	13.2
PMP1382	Boost (26V @ 44mA)	3.3	6.6
PMP1386	Sync Buck for Two Way Satellite Inte	7	40
PMP1400	Sync Buck (13.8V @ 5A)	18	30
PMP1402	Sync Buck (2.5V @ 20A)	10.8	13.2
PMP1446	Sync Buck for Telecom (1.8V @ 3.5A)	3.1	3.5

### WEBENCH® Design Center Saves Development Time and Cost

WEBENCH Design Center online design and prototyping tools put an award-winning online design environment right at your fingertips. Design, optimize, generate your prototype and download your test vectors—all online. And you can do it all for free, anywhere, anytime.

#### Select It—Choose from only those parts that meet your specifications

- Input your design requirements
- Choose a recommended part from a customized list

#### Design It—Create your custom BOM using readily available parts

- Tune your design quickly with the optimization tool to balance design objectives for efficiency and footprint
- Adjust components and use charts to make design decisions on a wide selection of electrical characteristics
- Exchange parts and use bill-of-materials graphs for easy external component selection based on efficiency, footprint, cost or vendors



#### Analyze It—Solve your design problems before you prototype

- Simulate your circuit and evaluate performance using electrical and thermal simulations
- Simulate electrical characteristics, choose probe points and examine waveforms to determine performance
- Simulate thermal behavior and your circuit on a PCB in your defined environment and view color heat maps
- Overlay alternate circuits and compare results to get optimal performance

#### Build It—Save weeks getting your final design into production











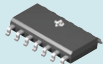

- Request samples and purchase parts or demo boards
- Receive your custom prototyping kit the next business day
- Download your automatically generated CAD files, assembly details, test instructions and complete performance results

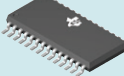
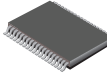
Get more information  
[www.ti.com/webench](http://www.ti.com/webench)

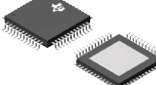
# Resources

## Packaging





### Surface Mount Packages

	Package Type	Package Designator	Key Characteristics
<b>Small Outline Packages</b>			
	Small Outline Integrated Circuit (SOIC)	D, DW, DWU, DTH, DTC, DDA, DVB, DWP	High MSL rating* (MSL1/MSL2), variable size availability
	Mini Small Outline Package (MSOP)	DGK, DGS	Small form factor, thin package
	Heat Sink Small Outline Package (HSOP)	DWP, DWD	Thermally enhanced SOP (low to mid power)
	Small Shrink Outline Package (SSOP)	DL, DB, DF, DBQ, DCE, DCT	High MSL rating* (MSL1/MSL2), higher stand-off height
	Thin Shrink Small Outline Package (TSSOP)	DA, PW, DBT	Variable pin count options available, high MSL rating* (MSL1/MSL2), small form factor
	Exposed Pad Thin Shrink Small Outline Package (HTSSOP)	PWP, DAP, DAD, DCA	Thermally enhanced TSSOP (low to high power); various pin count options available
	Power Small Outline Package (PSOP3)	DKP (slug down), DKD (slug up)	Very high power handling capability, mechanically robust package
<b>Quad Ledged Packages</b>			
	Thin Quad Flat Pack (TQFP)	PFB, PAG, PJT, PBS, PAG	High pin count, leadframe based package
	Exposed Pad Thin Quad Flat Pack (HTQFP)	PAP, PJD, PZP, PHP, PNP, PHD	Thermally enhanced TQFP (mid to high power)
<b>Small Outline Transistors</b>			
	Small Outline Transistor (SC-70)	DCK	Mini form factor
	Small Outline Transistor Package (SOT23)	DBV, DCN, DDC, thin SOT	Small form factor, high MSL rating* (MSL1/MSL2)
	Small Outline Transistor (SOT223)	DCY, DCQ	High MSL rating* (MSL1/MSL2)
	Transistor Outline (TO236)	DBZ	Small form factor
<b>Leaded Packages</b>			
	Plastic Flange Mount Package (DDPak/TO-263)	KTT, KTW	Very high power handling capability
<b>Leadless Packages</b>			
	Small Outline No Leads (SON)	DRB, DRC, DRD, DRK, DRM, DRN, DRT, DSE, DSG, DSJ	Small footprint, thermal package (low to mid power)

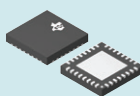
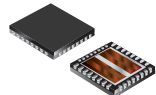

\*MSL rating should be checked for individual device.

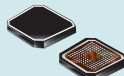
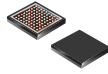

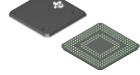
### Surface Mount Packages (Continued)

	Package Type	Package Designator	Key Characteristics
<b>Leadless Packages (Continued)</b>			
	Quad Flatpack No Leads (QFN)	RGC, RGE, RGF, RGP, RGT, RGW, RGY, RGZ, RHA, RHB, RHD, RHF, RHH, RHL, RSA, RSB, RSH, RSJ, RSL, RSM, RTE, RTH, RTQ, RTT, RUK, RUV, RVA	Compact footprint, thermal package (mid to high power), available in variable thicknesses
	Flip-Chip Power Packages	RSJ	High power handling capability
<b>Ball Grid Arrays (BGAs)</b>			
	Wafer Chip Scale Package (WCSP)/Die Sized Ball Grid Array (DSBGA)	YEG, YEK, YEJ, YEA, YZA, YED	Die size package, very small form factor, finer pitch
	MicroStar BGA™	ZGU	Controllable count density, variable thickness option availability
	MicroStar Junior™ BGA	ZQE, ZQZ	Smaller sized MicroStar BGA, controllable pin count density
	PicoStar™	YFM	Extremely small sized package, ultra-thin, board embeddable
	BGA	ZVD	Very high pin count density

### Through-Hole Packages

	Package Type	Package Designator	Key Characteristics
	Plastic Dual Inline Package (PDIP)	P, N, NT, NTD	Recommended for wave soldering, excellent board-level reliability
	Transistor Outline (TO220)	KC	Very high power handling capability, recommended for wave soldering, mechanically robust

### Package Modules

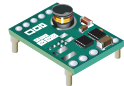
	Package Type	Package Designator	Key Characteristics
	Power Modules	—	Integrated passives, enhanced functionality



# Resources

## Packaging

### Connecting the PowerPAD™

The PowerPAD package should be connected to the appropriate internal signal plane as specified in the product datasheet. Depending on the electrical properties of the thermally conductive epoxy used to connect the Integrated Circuit (IC) to the lead frame, the PowerPAD may have a low impedance connection to the internal signal plane as specified in the product datasheet.

You can find additional information in the following resources. Technical literature can be accessed online with [www.ti.com/lit/litnumber](http://www.ti.com/lit/litnumber) by replacing

**litnumber** with one of the following literature numbers shown in parentheses.

- Remember to check the CAD format for your package under “Symbols/ Footprints,” available in all TI Product Folders
- Download the “PowerPAD Made Easy” application brief (SLMA004) in conjunction with the “PowerPAD Thermally Enhanced Package” technical brief (SLMA002)
- Specific information on QFN/SON packages is available in application reports (SLUA271 and SCBA017)
- Visit TI’s Analog & Mixed-Signal KnowledgeBase at: [support.ti.com/sc/knowledgebase](http://support.ti.com/sc/knowledgebase)
- Ask our experts your specific design questions via email by selecting Analog & Mixed-Signal email support in the Contact Tech Support frame at: [support.ti.com](http://support.ti.com)

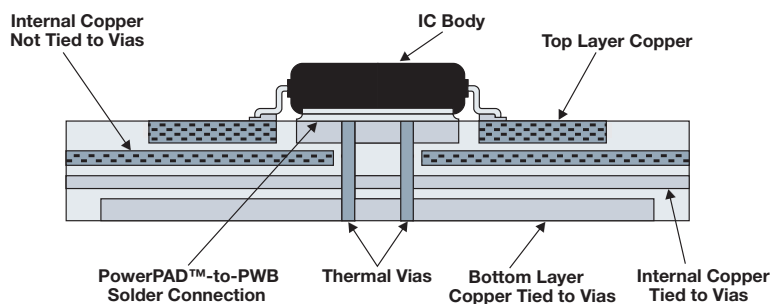

**Connect with your Power-Management peers and customers to ask questions, share knowledge, explore ideas, and solve problems.**

Join the discussion today!

[www.ti.com/e2epower](http://www.ti.com/e2epower)



**TI E2E™**  
**Community**  
**engineer.to.engineer,**  
**solving problems**

# Resources

## Device Index

Device	Page	Device	Page	Device	Page	Device	Page	Device	Page
bq2000/T	62, 63	bq24312	64	bq76PL536A	67	CSD18534KCS	46	LM2622	32
bq2002/C/E/F	62, 63	bq24313	64	bq77908A	69	CSD18534Q5A	46	LM2623	32
bq2004/E/H	62, 63	bq24314/A	64	bq77910A	69	CSD23201W10	44	LM26400Y	90
bq2005	62, 63	bq24314C	64	bq77PL157A4225	69	CSD25201W15	45	LM2642	38
bq2013H	67	bq24315	64	bq77PL900	69	CSD25301W1015	44	LM2647	38
bq2014H	67	bq24316	64	CSD16301Q2	45	CSD25302Q2	45	LM26480	90
bq2016	67	bq24350	64	CSD16321Q5	45	CSD25303W1015	44	LM2657	38
bq2019	67	bq24351	64	CSD16321Q5C	46	CSD25401Q3	45	LM2698	32
bq2022A	68	bq24352	64	CSD16322Q5	45	CSD75204W15	45	LM2700	32
bq2023	67	bq24380	64	CSD16322Q5C	46	CSD75205W1015	44	LM2731	32
bq2024	68	bq24381	64	CSD16323Q3	45	CSD75211W1723	45	LM27313	32
bq2031	62, 63	bq24382	64	CSD16323Q3C	46	CSD75301W1015	44	LM2733	32
bq2060A	67	bq24400/1	62, 63	CSD16325Q5	45	CSD86311W1723	45	LM2735	32
bq20z40	67	bq24450	62, 63	CSD16325Q5C	46	CSD86360Q5D	47	LM27402	37
bq20z45-R1	67	bq24600	59-61	CSD16327Q3	45	CSD87330Q3D	47	LM2742	37
bq20z60-R1	67	bq24610	59-61	CSD16327Q3C	45	CSD87331Q3D	47	LM2743	37
bq20z655-R1	67	bq24616	59-61	CSD16342Q5A	45	CSD87350Q5D	47	LM2744	37
bq20z65-R1	66, 67	bq24617	59-61	CSD16401Q5	44, 45	CSD87351Q5D	47	LM2745	37
bq24030/31/35	60, 61	bq24618	59-61	CSD16403Q5A	45	CSD87352Q5D	47	LM2747	37
bq24032A/38	60, 61	bq24620	59, 62, 63	CSD16404Q5A	45	CSD87353Q5D	47	LM2748	37
bq24040/41	60, 61	bq24630	59, 62, 63	CSD16406Q3	45	CSD96370Q5M	47	LM2756	84
bq24050/52	60, 61	bq24640	59, 62, 63	CSD16407Q5	45	CSD96371Q5M	47	LM2771	39
bq24055	60, 61	bq24650	59, 62, 63	CSD16407Q5C	46	CSD97370Q5M	47	LM2772	39
bq24072/72T	60, 61	bq24707A	60, 61	CSD16408Q5	45	INA210	111	LM2773	39
bq24073	60, 61	bq24725A	60, 61	CSD16408Q5C	46	INA219	111	LM2852	28
bq24074	60, 61	bq24735	60, 61	CSD16409Q3	45	INA226	111	LM2853	28
bq24075T/79T	60, 61	bq24765	62, 63	CSD16410Q5A	45	INA230	111	LM2854	28
bq24090/91	60, 61	bq25040	60, 61	CSD16411Q3	45	INA282	111	LM2936HV	50
bq24092/93	60, 61	bq25050	60, 61	CSD16412Q5A	45	LM(2)5005	26	LM3000	38
bq24100	58	bq25060	60, 61	CSD16413Q5A	45	LM(2)5007	26	LM3100	28
bq24103A	58	bq25070	52, 62, 63	CSD16414Q5	45	LM(2)5010/A	26	LM3102	28
bq24105	58	bq25504	52, 62, 63	CSD16556Q5B	45	LM(2)5037	9	LM3103	28
bq24108	58	bq25505	62, 63	CSD17301Q5A	45	LM(2)5085/A	37	LM3150	36
bq24113A	58	bq25570	62, 63	CSD17302Q5A	45	LM(2)5088	37	LM3151	36
bq24115	58	bq26100	68	CSD17303Q5	46	LM(2)5115/A	10, 37	LM3152	36
bq24130	58, 60, 61	bq26150	68	CSD17304Q3	45	LM(2)5116	37	LM3153	36
bq24133	58, 60, 61	bq26200	67	CSD17305Q5A	45	LM(2)5117	36, 37	LM3209-G3	42
bq24140	60, 61	bq26220	67	CSD17306Q5A	45	LM(2)5118	38	LM3212	42
bq24153A/58	60, 61	bq27010	65, 67	CSD17307Q5A	45	LM(2)5119	38	LM3224	32
bq24156A/59	60, 61	bq27210	65, 67	CSD17308Q3	45	LM10502	91	LM3241	42
bq24160	53, 60, 61	bq27410	65	CSD17309Q3	45	LM1084	50	LM3242	42
bq24161	53, 60, 61	bq27425	65, 67	CSD17310Q5A	45	LM20123/33/43	25	LM3243	42
bq24163	53, 60, 61	bq27500	65	CSD17311Q5	46	LM20124/34/44/54	25	LM3262	42
bq24165	53, 60, 61	bq27501	65	CSD17312Q5	46	LM20125/45	25	LM3269	42
bq24166	53, 60, 61	bq27505	65, 67	CSD17313Q2	45	LM20136/46	25	LM3280	90
bq24167	53, 60, 61	bq27510	65, 67	CSD17322Q5A	46	LM20242	26	LM3310	32
bq24168	53, 60, 61	bq27520	65	CSD17327Q5A	46	LM20323/33/43	26	LM3311	32
bq24170	58, 60, 61	bq27541	65, 67, 68	CSD17501Q5A	46	LM21212-1	25	LM3402/02HV	77
bq24171	58, 60, 61	bq27545	65	CSD17505Q5A	46	LM21212-2	25	LM3404/04HV	77
bq24172	58, 60, 61	bq28400	67	CSD17506Q5A	46	LM21215	25	LM3406/06HV	77
bq24180	60, 61	bq28550	65, 67	CSD17507Q5A	46	LM21215A	25	LM3409/HV	77
bq24185	60, 61	bq28z560	65, 67	CSD17510Q5A	46	LM21305	25	LM3410	77
bq24190	54, 60, 61	bq2920x	69	CSD17522Q5A	46	LM22670/73/76	28	LM3414/HV	77
bq24192	54, 60, 61	bq2941x	66, 69	CSD17527Q5A	46	LM22671/74	28	LM3421/23/29	77
bq24193	54, 60, 61	bq2944x	69	CSD17551Q3A	45	LM22672/75	28	LM3424	77
bq24195	55, 60, 61	bq2945xy	69	CSD17551Q5A	46	LM22677/78/79	28	LM3430	38
bq24195L	55, 60, 61	bq2946xy	69	CSD17552Q3A	45	LM22680	28	LM3431	77
bq24196	54, 60, 61	bq3050	67	CSD17552Q5A	46	LM25011/A	26	LM3433/34	77
bq24210	62, 63	bq3055	67	CSD17553Q5A	46	LM25056/A	95	LM3444	76
bq24250/51	56, 60, 61	bq3060	67	CSD17555Q5A	46	LM25061	94	LM3445	76
bq24253	56, 60, 61	bq33100	67	CSD17559Q5	46	LM25066/A	93, 95	LM3447	74, 76
bq24257	56, 60, 61	bq34z100	67	CSD18501Q5A	46	LM25066I/A	93, 95	LM3448	76
bq24259	60, 61	bq34z110	67	CSD18502KCS	46	LM25069	94	LM3450/A	76
bq24260	57, 60, 61	bq34z651	67	CSD18502Q5B	46	LM25101A/B/C	14	LM3464/A	77
bq24261	57, 60, 61	bq500210	62, 72	CSD18503KCS	46	LM25574	28	LM3466	77
bq24265	57, 60, 61	bq500211A	62, 72	CSD18503Q5A	46	LM25575	28	LM3475	37
bq24270/71	60, 61	bq500410A	62, 72, 73	CSD18504KCS	46	LM25576	28	LM3477	37
bq24272	60, 61	bq51011	62, 63, 70, 71	CSD18504Q5A	46	LM2585	33	LM3478	38
bq24273	60, 61	bq51013	62, 63, 70, 71, 73	CSD18531Q5A	46	LM2586	33	LM3481	38
bq24278	60, 61	bq51013A	62, 63, 70, 71, 73	CSD18532KCS	46	LM2587	33	LM3485	37
bq24300/4/5	64	bq51013B	62, 63, 70, 71	CSD18532Q5B	46	LM2588	33	LM3488	38
bq24308	64	bq51050B/51B	62, 63, 70, 71	CSD18533KCS	46	LM26001	26	LM3489	37
		bq76925	69	CSD18533Q5A	46	LM26003	26	LM34902/4	97

# Resources

## Device Index

Device	Page	Device	Page	Device	Page	Device	Page	Device	Page
LM34910/C	26	LM5067	94	LP3470	109	PTH08T250/255W	20	TLC59461	87
LM34917A	26	LM5068	94	LP38511/2/3	50	PTH08T260/261W	20	TLC5947	87
LM34919/B	26	LM5069	94	LP3851x	50	PTH12000L/W	20	TLC5948A	87
LM3492	77	LM5070	99	LP3878-ADJ	50	PTH12010/50/60L	112	TLC5951	87
LM34927/6/5	9, 103	LM5071	99	LP3881/2/3	50	PTH12010L/W	20	TLC5952	87
LM3492HC	77	LM5072	99	LP38851	50	PTH12010Y	20	TLC5960	84
LM3528	83	LM5073	99	LP38852/5/8	50	PTH12020L/W	20	TLC5970	87
LM3530	83	LM5100A/B/C	14	LP38853/6/9	50	PTH12030L/W	20	TLC5971	87
LM3532	83	LM5101A/B/C	14	LP3907	90	PTH12040W	20	TLC77xx	109
LM3533	83	LM5110	13, 103	LP3910	90	PTH12050L/W	20	TLV62065	29
LM3535	83	LM5111	13	LP3925	90	PTH12050Y	20	TLV62080	29
LM3537	83	LM5112	13	LP3974	90, 91	PTH12060L/W	20	TLV62090	29
LM3538	83	LM5113	12, 14, 103	LP3996	50	PTH12060Y	20	TLV62130	29
LM3550	85	LM5114A/B	13	LP5521	84	PTN04050A	21	TLV62150	29
LM3554	85	LM5134	13	LP5522	84	PTN04050C	20	TLV710	50
LM3555	85	LM5574	28	LP5523	84	PTN78000A	21	TLV711	50
LM3556	85	LM5575	28	LP5524	84	PTN78000W/H	20	TLV803	109
LM3559	85	LM5576	28	LP5900/4/7	50	PTN78020A	21	TLV809	109
LM3560	85	LM5642	38	LP5907	50	PTN78020W/H	20	TLV810	109
LM3561	85	LM5642x	38	LP5996	50	PTN78060A	21	TPS2000C/1C	102
LM3565	85	LM809	109	LP8543	83	PTN78060W/H	20	TPS2002C/3C	102
LM3630	83	LM810	109	LP8545	83	PTR08060W	20	TPS2010A	102
LM3642	85	LM8364	109	LP8550	83	PTR08100W	20	TPS2011A	102
LM3668	34	LM8365	109	LP8552	82, 83	PTV03010W	20	TPS2012A	102
LM3670	29	LM8502	84	LP8553	83	PTV03020W	20	TPS2013A	102
LM3671	29	LM8801	29	LP8556	82, 83	PTV05010W	20	TPS2020/30	102
LM3678	30	LM9076	50	LP8720	90	PTV05020W	20	TPS2021/31	102
LM3686	90	LMC6953	109	LP8725	90	PTV08T250W	20	TPS2022/32	102
LM3691	30	LMH2100	43	LP8765	90	PTV12010L/W	20	TPS2023/33	102
LM3704	109	LMH2110	43	LP8788	90, 91	PTV12020L/W	20	TPS2024/34	102
LM3710	109	LMH2120	43	LP8900	50	REG710	40	TPS2041C/51C	102
LM3724	109	LMH2121	43	MC34063A	32, 33	REG71050	40, 83	TPS2043B/53B	102
LM3743	37	LMP8640	111	PTD08A006W	107	REG711	40	TPS2044B/54B	102
LM3753	37, 38	LMP8645	111	PTD08A010W	107	TCA6507	83	TPS2045A/55A	102
LM3753/54	37	LMP8646	111	PTD08A015W	107	TL3842B/3B/4B/5B	9	TPS2049	102
LM3754	38	LMR10510	27	PTD08A020W	107	TL4242	8	TPS2052C	102
LM3880	110	LMR10515	27	PTD08A210W	107	TL494 or TL594	9	TPS2060C/4C/4C-2	102
LM3881	110	LMR10520	27	PTD08D210W	107	TL497A	32, 33	TPS2061C/65C/65C-2	102
LM4510	32	LMR12010	27	PTH03000W	20	TL499A	33	TPS2062C/6C/6C-2	102
LM5000	32	LMR14203	27	PTH03010/50/60W	112	TL598	9	TPS2063/7	102
LM5001	32	LMR14206	27	PTH03010W	20	TL7660	39	TPS2068/9	102
LM5002	32	LMR24210	27	PTH03010Y	20	TLC59025	87	TPS2069C/69C-2	102
LM5006	26	LMR24220	27	PTH03020W	20	TLC59108	87	TPS2080/1/2	102
LM5008/A	26	LMR62014	33	PTH03030W	20	TLC59108F	87	TPS2085/6/7	102
LM5009/A	26	LMR62421	33	PTH03050W	20	TLC59116	87	TPS2090/1/2	102
LM5015	9	LMR64010	33	PTH03050Y	20	TLC59116F	87	TPS2095/6/7	102
LM5017	9, 25, 26	LMR70503	33	PTH03060W	20	TLC5916	87	TPS22901	97
LM5018	26	LMS1585A	50	PTH03060Y	20	TLC5917	87	TPS22902/B	97
LM5019	26	LMS33460	109	PTH04000W	20	TLC59208F	87	TPS22903	97
LM5020	9, 38	LMV221	43	PTH04040W	20	TLC5921	87	TPS22906	97
LM5021	9, 38	LMV225	43	PTH04070W	20	TLC59210	87	TPS22907	97
LM5022	9, 38	LMV226	43	PTH04T220/221W	20	TLC59211	87	TPS22910A	97
LM5022/C	38	LMV228	43	PTH04T230/231W	20	TLC59212	87	TPS22912C	97
LM5023	10	LMV232	43	PTH04T240/241W	20	TLC59213/A	87	TPS22913B	97
LM5025/A/B/C	9	LMV242	43	PTH04T260/261W	20	TLC5922	87	TPS22913C	97
LM5026	9	LMZ10500	17, 27	PTH05000W	20	TLC5923	87	TPS22920	97
LM5027/A	9	LMZ10501	17	PTH05010/50/60W	112	TLC5924	87	TPS22921	97
LM5030	10	LMZ10503/04/05	16	PTH05010W	20	TLC5925	87	TPS22922/B	97
LM5032	9	LMZ10503/04/05EXT	16	PTH05010Y	20	TLC5926	87	TPS22924B/C	97
LM5033	10	LMZ12001/02/03	16	PTH05020W	20	TLC5927	87	TPS22929D	97
LM5034	9	LMZ12001/02/03EXT	16	PTH05030W	20	TLC5928	87	TPS22941	97
LM5035/A/B/C	9	LMZ12008/10	16	PTH05050W	20	TLC59281	87	TPS22942	97
LM5039	9	LMZ13608/10	16	PTH05050Y	20	TLC59282	87	TPS22943	97
LM5041/A/B	10	LMZ14201/02/03	16	PTH05060W	20	TLC5929	86, 87	TPS22944	97
LM5045	7, 9	LMZ14201/02/03EXT	16	PTH05060Y	20	TLC5930	87	TPS22945	97
LM5046	7, 10	LMZ14201H/02H/03H	16	PTH05T210W	20	TLC5940	87	TPS22946	97
LM5050-1	95	LMZ22003/5	16	PTH08000W	20	TLC59401	87	TPS22949/A	97
LM5050-2	95	LMZ22008/10	16	PTH08080W	20	TLC5941	87	TPS22951	97
LM5051	95	LMZ23603/5	16	PTH08T210W	20	TLC5942	87	TPS22966	97
LM5056	95	LMZ23608/10	16	PTH08T220/221W	19, 20	TLC5943	87	TPS2300/01	94
LM5060/Q	94	LP2966	50	PTH08T230/231W	20	TLC5944	87	TPS2310/11	94
LM5064	95, 103	LP2967	50	PTH08T240/241W	20	TLC5945	87	TPS2320/21	94
LM5066	95, 103	LP2989/LV	50	PTH08T240F	20	TLC5946	87	TPS2330/31	94

# Resources

## Device Index

Device	Page	Device	Page	Device	Page	Device	Page	Device	Page
TPS2342	94	TPS2590	93, 102	TPS40040	37	TPS54527/8	25	TPS61131/2	34
TPS2343	94	TPS25910	93	TPS40041	37	TPS54540/60	26	TPS61140	83
TPS2350	94	TPS2811	13	TPS40042	37, 112	TPS54618/78	25	TPS61150A	83
TPS2358	94, 95	TPS2812	13	TPS40054/55/57	37	TPS54620	26	TPS61160	83
TPS2359	94, 95	TPS2813	13	TPS40056	37	TPS54623	26	TPS61160A	83
TPS2363	94	TPS2814	13	TPS40057	112	TPS54672	112	TPS61161	83
TPS2375/-1	99	TPS2815	13	TPS40075	37	TPS54821	26	TPS61161A	83
TPS23750/70	98, 99	TPS2816	13	TPS40077	37	TPS54972	112	TPS61165	83
TPS23751/2	98, 99	TPS2817	13	TPS40100	37	TPS55010	9	TPS61166	83
TPS23753A	98, 99	TPS2818	13	TPS40101	37	TPS55340	32	TPS61170	32
TPS23754/6	99	TPS2819	13	TPS40132	38	TPS55383/6	26	TPS61175	32
TPS23757	99	TPS28225	14	TPS40140	38	TPS56121	26	TPS61176	82, 83
TPS2376	99	TPS28226	14	TPS40170	37	TPS56221	26	TPS61183/87	83
TPS2376-H	99	TPS2828	13	TPS40180	38	TPS59116	38	TPS61185	83
TPS2377	99	TPS2829	13	TPS40190	37	TPS59124	38	TPS61195	83
TPS2377-1	99	TPS2830	14	TPS40192/3	37	TPS59610/11	38	TPS61196	83
TPS2378	98, 99	TPS2831	14	TPS40195	37	TPS59621	38	TPS61199	81
TPS2379	98, 99	TPS2832	14	TPS40200	37	TPS59640	38	TPS61200/1/2	32
TPS2384	99	TPS2833	14	TPS40210/1	38	TPS59641	38	TPS61220/21/22	32
TPS23841	99	TPS2834	14	TPS40211	77	TPS59650	38	TPS61230	32
TPS23851	98, 99	TPS2835	14	TPS40303/4/5	37	TPS60100	39	TPS61240/41	32
TPS2390	94	TPS2836	14	TPS40322	38	TPS60101	39	TPS61251	32
TPS2391	94	TPS2837	14	TPS40400	35, 37	TPS60110	39	TPS61252	31, 32
TPS2392	94	TPS2838	14	TPS40422	38	TPS60111	39	TPS61253/58/59	32
TPS2393	94	TPS2839	14	TPS43000	38	TPS6012x	39	TPS61254/6	32
TPS2393A	94	TPS2848	14	TPS43060	38	TPS6013x	39	TPS61260/61	32
TPS2394	94	TPS2849	14	TPS51020	112	TPS6014x	39	TPS61300/1/5	85
TPS2398	94	TPS3103	109	TPS51100	112	TPS60150	39	TPS61310/1	85
TPS2399	94	TPS3106	109	TPS51116	112	TPS6020x	39	TPS61325	85
TPS2400	94	TPS3110	109	TPS51200	112	TPS60210	39	TPS62050	29
TPS2410	95	TPS3123	109	TPS51206	112	TPS6021x	39	TPS62060	29
TPS2411	95	TPS3124	109	TPS51216/716/916	112	TPS60230/1	83	TPS62065	29
TPS2412	95	TPS3125	109	TPS51220A	38	TPS60240	39, 40	TPS62067	29
TPS2413	95	TPS3126	109	TPS51225/B/C	38	TPS60250/5	83	TPS62080	29, 30
TPS2419	95	TPS3128	109	TPS51275/C	38	TPS60251	83	TPS62090	29
TPS2420	93	TPS3305-xx	109	TPS51315	26	TPS6030x	39, 40	TPS62110	29
TPS2421-1	93	TPS3306-xx	109	TPS51362/7	112	TPS6031x	40	TPS62120	29
TPS2421-2	93	TPS3307-xx	110	TPS51631	38	TPS60400	39, 40	TPS62125	29
TPS2456	94, 95	TPS3420/1/2	111	TPS53114	37	TPS60401	40	TPS62130	29
TPS2458	94	TPS3510/1	110	TPS53124	37	TPS60402	40	TPS62140	29
TPS2459	94	TPS3513/4	110	TPS53125/26/27	37	TPS60403	40	TPS62150	25, 29
TPS24700	94	TPS3600	110	TPS53211	38	TPS60500	39	TPS62160	29
TPS24701	94	TPS3606-33	110	TPS53219	38	TPS61010	32	TPS62170	25, 29
TPS24710	94	TPS3610	110	TPS53311	25	TPS61014/5/6	32	TPS62175	26, 29
TPS24711	94	TPS3613-01	110	TPS53313	25	TPS61020	32	TPS62230	29
TPS24712	94	TPS3619	110	TPS53316	25	TPS61024/5/7	32	TPS62240	29
TPS24713	94	TPS3700	108, 109	TPS53317	112	TPS61026/9	32	TPS62250	29
TPS24720	94	TPS3705-xx	109	TPS53355	26	TPS61028	32	TPS62260	29
TPS2480/1	95	TPS3707-xx	109	TPS54020	23, 26	TPS61030/1/2	32	TPS62270	30
TPS2490	94	TPS3800	109	TPS54040A/60A	26	TPS61040	32, 83	TPS62290	29
TPS2491	94	TPS3801	109	TPS54061	26	TPS61041	32, 83	TPS62360	30
TPS2492	94	TPS3802	109	TPS54062	26	TPS61042	83	TPS62366	30
TPS2493	94	TPS3803	109	TPS5410	26	TPS61043	83	TPS623850	30
TPS2500	100	TPS3805	109	TPS54140A/60A	26	TPS61045	83	TPS623860	30
TPS2511	102	TPS3806	110	TPS5420	26	TPS61050/2	85	TPS62387A	30
TPS2540/40A	101	TPS3807	109	TPS54218	25	TPS61054/5	85	TPS62400	29
TPS2540/A/1/1A/3	102	TPS3808	109	TPS54227/8	25	TPS61060	83	TPS62410	29
TPS2541/41A	101	TPS3813	109	TPS54231/2/3	26	TPS61061	83	TPS62420	29
TPS2552	93, 102	TPS3820/8-xx	109	TPS54240/60	26	TPS61062	83	TPS62510	29
TPS2552/53	102	TPS3823	109	TPS54283/6	26	TPS61070/1/2/3	32	TPS62560	29
TPS2552-1	93, 102	TPS3824-xx	109	TPS54290/1/2	26	TPS61080	32	TPS62619	29
TPS2552-1/53-1	102	TPS3825-xx	109	TPS54294/95	26	TPS61081	32	TPS62620	30
TPS2553	93	TPS3836/8	109	TPS5430	26	TPS61085	79	TPS62650	30
TPS2553-1	93	TPS3837	109	TPS54318	25	TPS61087	79	TPS62660	30
TPS2554	93, 102	TPS3860x0	110	TPS54320	25	TPS61090	32	TPS62674	29
TPS2554/55	102	TPS386596	110	TPS54327/8	25	TPS61091/2	32	TPS62690	29
TPS2555	93	TPS3895	109	TPS54331	26	TPS61093	32	TPS62730	29, 42
TPS2556	93, 102	TPS3896	109	TPS54332	26	TPS61097-33	32	TPS62736	29
TPS2556/57	102	TPS3897	109	TPS54340/60	26	TPS61100	33	TPS62750	29
TPS2557	93	TPS3898	109	TPS54372	112	TPS61103/6/7	33	TPS63000/1/2	34
TPS2560/61	102	TPS40000/2	37	TPS54418/78	25	TPS61120	33	TPS63010/11/12	34
TPS2560/A	93	TPS40007/9	37	TPS54494/95	26	TPS61121/2	33	TPS63020	34
TPS2561/A	93	TPS40020/21	37	TPS5450	26	TPS61130	34	TPS63030/31/36	34

# Resources

## Device Index

Device	Page	Device	Page	Device	Page	Device	Page	Device	Page
TPS63050	34	TPS65257/8	90	TPS81256	21	UCC25230	9, 103	UCC3583	10
TPS63060/1	34	TPS65270	90	TPS82660	17	UCC25600	10, 84	UCC37321	13
TPS63700	33	TPS65280/1/2	90	TPS82671	17	UCC25710	84	UCC37322	13
TPS65000/6	90	TPS65290	88, 91	TPS82680	17	UCC27200/A	14	UCC3800/1/2/3/4/5	9
TPS65023x	90	TPS65320	91	TPS82695	17	UCC27201/A	14	UCC3806	10
TPS650250	90, 91	TPS65381-Q1	90, 91	TPS84210	18	UCC27210	14, 103	UCC3807-1-2-3	9
TPS650380	88, 90	TPS65631	78, 80	TPS84250	18	UCC27211	14	UCC3808-1/-2/A-1/A-2	10
TPS65050/1/2/4/6	90	TPS65632A	80	TPS84259	18, 21	UCC27221	14	UCC3808/4/5/6	9
TPS65053/8	90	TPS65720/1	90	TPS84320	18	UCC27222	14	UCC3809-1-2	9
TPS65070/2/3	90	TPS65735/835	91	TPS84410	18	UCC27223	14	UCC3810	10
TPS65090	89, 91	TPS658310	91	TPS84420	18	UCC27323	13	UCC3813-0/1/2/3/4/5	9
TPS65100	79	TPS65862x/4x	90	TPS84610	18	UCC27324	13	UCC3884	9
TPS65105	79	TPS659038-Q1	90, 91	TPS84621	18	UCC27325	13	UCC3888/89	9
TPS65120	80	TPS659039-Q1	90	TPS84720	18	UCC27423	13	UCC3895	10
TPS65121	80	TPS65910x	90, 91	TPS84A20	18	UCC27424	13	UCC38C40/1/2/3/4/5	9
TPS65124	80	TPS659110/2/3/9	90	TPS84B20	18	UCC27425	13	UCC3912	93
TPS65130	80	TPS659119-Q1	90	TPS84C20	18	UCC27511	13	UCC3915	93
TPS65131	80	TPS65912x	90	TPS92001	76	UCC27512	13	UCC3918	93
TPS65135	80	TPS65914	89-91	TPS92002	76	UCC27516	13	UCC3919	94
TPS65136	80	TPS65921	90	TPS92020	76	UCC27517	13	UCD3020	107
TPS65137A	80	TPS65930	90	TPS92070	76	UCC27518	13	UCD3028	107
TPS65138	80	TPS65950	90	TPS92075	75, 76	UCC27519	13	UCD3040	107
TPS65140	79	TPS65951	90	TPS92210	76	UCC27523	13	UCD3138	106, 107
TPS65142	79	TPS709	50	TPS92310	76	UCC27524	13, 103	UCD7100	107
TPS65145	79	TPS709xx	50	TPS92311	76	UCC27525	13	UCD7201	107
TPS65148	79	TPS712xx	50	TPS92314/A	76	UCC27526	13	UCD7230	14
TPS65149	79	TPS715A	50	TPS92510	77	UCC27531	13	UCD7231	107
TPS65150	79	TPS717	50	TPS92550	76, 77	UCC27532	13	UCD7232	107
TPS65160/A	79	TPS71701	50	TPS92551	76, 77	UCC27533	13	UCD7242	107
TPS65161	79	TPS718xx	50	TPS92560	77	UCC27536	13	UCD74106	107
TPS65161A	79	TPS719xx	50	TPS92660	77	UCC27537	13	UCD74111	107
TPS65161B	79	TPS720xx	50	TPS92690	77	UCC27538	13	UCD74120	107
TPS65162	79	TPS727	50	TWL6030/32/40/41	90	UCC27611	13	UCD90120A	110
TPS65163	79	TPS727xx	50	UC28023	9	UCC28063	5	UCD90124A	110
TPS65165	79	TPS731/2/6	50	UC28025	10	UCC28070	5	UCD90160	110
TPS65168	79	TPS735/7	50	UC3524A	10	UCC28089	9	UCD9090	110
TPS65170	79	TPS742/3/4	50	UC3525B	10	UCC28220/1	10	UCD90910	110
TPS65176	79	TPS742/3/8	50	UC3526A	10	UCC28230/1	9	UCD9222/442	107
TPS65177	78, 79	TPS744/9	50	UC3714	13	UCC28250/1	10	UCD9224	107
TPS65178	79	TPS74701	50	UC3715	13	UCC28600	10	UCD9248/6	105, 107
TPS65185	80	TPS75103/5	83	UC3823	9	UCC28610	10		
TPS65186	80	TPS780/2xx	50	UC3823A/B	9	UCC28700/1/2/3	10		
TPS65192	79	TPS797xx	50	UC3824	9	UCC28710/1	10		
TPS65193	79	TPS799xx	50	UC3825	10	UCC28810	76		
TPS65194	79	TPS7A16xx	49, 50	UC3825A/B	10	UCC28811	76		
TPS65196	79	TPS7A3001	48, 50	UC3827-1/-2	10	UCC2891/3	10		
TPS65197	79	TPS7A3301	50	UC3842A/3A/4A/5A	9	UCC2892/4	10		
TPS65198	79	TPS7A40xx	50	UC3846/56	10	UCC28950	8, 10		
TPS65200	91	TPS7A4700	48, 50	UC3875/6/7	10	UCC2897A	10		
TPS65217	90, 91	TPS7A4901	48, 50	UC3879	10	UCC35701/2	9		
TPS65250/1	90	TPS7A71/2/3	50	UC3909	62, 63	UCC35705/6	9		
TPS65253	90	TPS7A8101	50	UCC24610	14	UCC3580-1/-2/-3/-4	10		

# WEBENCH® Design Center

Get results faster with easy-to-use design tools that deliver custom results.

Quickly compare performance across multiple parameters for complete systems

- Designer Series— Single-circuit design tools
- Architect Series— Advanced hierarchical design tools
- Unique Design Features— Visualizer and Optimizer Dial

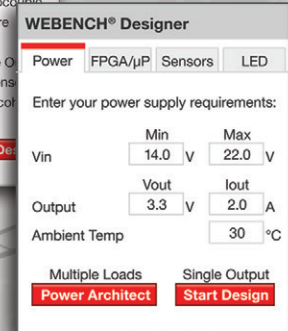
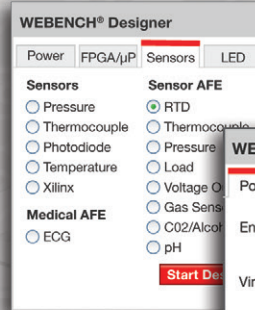
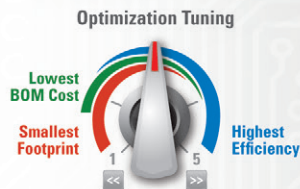

[www.ti.com/webench](http://www.ti.com/webench)

## TI Worldwide Technical Support

### Internet

TI Semiconductor Product Information Center Home Page

[support.ti.com](http://support.ti.com)

TI E2E™ Community Home Page

[e2e.ti.com](http://e2e.ti.com)

### Product Information Centers

<b>Americas</b>	Phone	+1(512) 434-1560
<b>Brazil</b>	Phone	0800-891-2616
<b>Mexico</b>	Phone	0800-670-7544
	Fax	+1(972) 927-6377
	Internet/Email	<a href="http://support.ti.com/sc/pic/americas.htm">support.ti.com/sc/pic/americas.htm</a>

### Europe, Middle East, and Africa

Phone	
European Free Call	00800-ASK-TEXAS (00800 275 83927)
International	+49 (0) 8161 80 2121
Russian Support	+7 (4) 95 98 10 701
<b>Note:</b>	The European Free Call (Toll Free) number is not active in all countries. If you have technical difficulty calling the free call number, please use the international number above.

Fax	+ (49) (0) 8161 80 2045
Internet	<a href="http://www.ti.com/asktexas">www.ti.com/asktexas</a>
Direct Email	<a href="mailto:asktexas@ti.com">asktexas@ti.com</a>

### Japan

Phone	Domestic	0120-92-3326
Fax	International	+81-3-3344-5317
	Domestic	0120-81-0036
Internet/Email	International	<a href="http://support.ti.com/sc/pic/japan.htm">support.ti.com/sc/pic/japan.htm</a>
	Domestic	<a href="http://www.tij.co.jp/pic">www.tij.co.jp/pic</a>

### Asia

Phone

International +91-80-41381665

Domestic Toll-Free Number

**Note:** Toll-free numbers do not support mobile and IP phones.

Australia	1-800-999-084	Malaysia	1-800-80-3973
China	800-820-8682	New Zealand	0800-446-934
Hong Kong	800-96-5941	Philippines	1-800-765-7404
India	1-800-425-7888	Singapore	800-886-1028
Indonesia	001-803-8861-1006	Taiwan	0800-006800
Korea	080-551-2804	Thailand	001-800-886-0010

Fax +8621-23073686

Email [tiasia@ti.com](mailto:tiasia@ti.com) or [ti-china@ti.com](mailto:ti-china@ti.com)

Internet [support.ti.com/sc/pic/asia.htm](http://support.ti.com/sc/pic/asia.htm)

**Important Notice:** The products and services of Texas Instruments Incorporated and its subsidiaries described herein are sold subject to TI's standard terms and conditions of sale. Customers are advised to obtain the most current and complete information about TI products and services before placing orders. TI assumes no liability for applications assistance, customer's applications or product designs, software performance, or infringement of patents. The publication of information regarding any other company's products or services does not constitute TI's approval, warranty or endorsement thereof.

B090712

**Trademarks:** The platform bar, Auto-Track, bqTESLA, Code Composer Studio, D-CAP, D-CAP+, D-CAP2, DCS-Control, DualCool, Dynamic Rectifier Control, E2E, EasyScale, Eco-mode, Fly-Buck, Fusion Digital Power, HotRod, iHVM, Impedance Track, MicroSiP, MicroStar BGA, MicroStar Junior, MSP430, my.TI, NanoFree, Natural Interleaving, NexFET, OMAP, PicoStar, POLA, PowerLab, PowerPAD, PowerStack, Predictive Gate Drive, SDQ, SmartReflex, SWIFT, TPS40K, TrueDrive and TurboTrans are trademarks and SIMPLE SWITCHER and WEBENCH are registered trademarks of Texas Instruments. ARM7 is a trademark and ARM and Cortex are registered trademarks of ARM Limited. The *Bluetooth* word mark and logos are owned by the Bluetooth SIG, Inc., and any use of such marks by Texas Instruments is under license. CompactPCI is a registered trademark of PCI Computer Manufacturers Group, Inc. (PICMG). PCI Express and PCI-X are registered trademarks of PCI-SIG Corporation. E Ink and Vizplex are registered trademarks of E Ink Corporation. All other trademarks are the property of their respective owners.



## IMPORTANT NOTICE

Texas Instruments Incorporated and its subsidiaries (TI) reserve the right to make corrections, enhancements, improvements and other changes to its semiconductor products and services per JESD46, latest issue, and to discontinue any product or service per JESD48, latest issue. Buyers should obtain the latest relevant information before placing orders and should verify that such information is current and complete. All semiconductor products (also referred to herein as "components") are sold subject to TI's terms and conditions of sale supplied at the time of order acknowledgment.

TI warrants performance of its components to the specifications applicable at the time of sale, in accordance with the warranty in TI's terms and conditions of sale of semiconductor products. Testing and other quality control techniques are used to the extent TI deems necessary to support this warranty. Except where mandated by applicable law, testing of all parameters of each component is not necessarily performed.

TI assumes no liability for applications assistance or the design of Buyers' products. Buyers are responsible for their products and applications using TI components. To minimize the risks associated with Buyers' products and applications, Buyers should provide adequate design and operating safeguards.

TI does not warrant or represent that any license, either express or implied, is granted under any patent right, copyright, mask work right, or other intellectual property right relating to any combination, machine, or process in which TI components or services are used. Information published by TI regarding third-party products or services does not constitute a license to use such products or services or a warranty or endorsement thereof. Use of such information may require a license from a third party under the patents or other intellectual property of the third party, or a license from TI under the patents or other intellectual property of TI.

Reproduction of significant portions of TI information in TI data books or data sheets is permissible only if reproduction is without alteration and is accompanied by all associated warranties, conditions, limitations, and notices. TI is not responsible or liable for such altered documentation. Information of third parties may be subject to additional restrictions.

Resale of TI components or services with statements different from or beyond the parameters stated by TI for that component or service voids all express and any implied warranties for the associated TI component or service and is an unfair and deceptive business practice. TI is not responsible or liable for any such statements.

Buyer acknowledges and agrees that it is solely responsible for compliance with all legal, regulatory and safety-related requirements concerning its products, and any use of TI components in its applications, notwithstanding any applications-related information or support that may be provided by TI. Buyer represents and agrees that it has all the necessary expertise to create and implement safeguards which anticipate dangerous consequences of failures, monitor failures and their consequences, lessen the likelihood of failures that might cause harm and take appropriate remedial actions. Buyer will fully indemnify TI and its representatives against any damages arising out of the use of any TI components in safety-critical applications.

In some cases, TI components may be promoted specifically to facilitate safety-related applications. With such components, TI's goal is to help enable customers to design and create their own end-product solutions that meet applicable functional safety standards and requirements. Nonetheless, such components are subject to these terms.

No TI components are authorized for use in FDA Class III (or similar life-critical medical equipment) unless authorized officers of the parties have executed a special agreement specifically governing such use.

Only those TI components which TI has specifically designated as military grade or "enhanced plastic" are designed and intended for use in military/aerospace applications or environments. Buyer acknowledges and agrees that any military or aerospace use of TI components which have **not** been so designated is solely at the Buyer's risk, and that Buyer is solely responsible for compliance with all legal and regulatory requirements in connection with such use.

TI has specifically designated certain components as meeting ISO/TS16949 requirements, mainly for automotive use. In any case of use of non-designated products, TI will not be responsible for any failure to meet ISO/TS16949.

### Products

Audio	<a href="http://www.ti.com/audio">www.ti.com/audio</a>
Amplifiers	<a href="http://amplifier.ti.com">amplifier.ti.com</a>
Data Converters	<a href="http://dataconverter.ti.com">dataconverter.ti.com</a>
DLP® Products	<a href="http://www.dlp.com">www.dlp.com</a>
DSP	<a href="http://dsp.ti.com">dsp.ti.com</a>
Clocks and Timers	<a href="http://www.ti.com/clocks">www.ti.com/clocks</a>
Interface	<a href="http://interface.ti.com">interface.ti.com</a>
Logic	<a href="http://logic.ti.com">logic.ti.com</a>
Power Mgmt	<a href="http://power.ti.com">power.ti.com</a>
Microcontrollers	<a href="http://microcontroller.ti.com">microcontroller.ti.com</a>
RFID	<a href="http://www.ti-rfid.com">www.ti-rfid.com</a>
OMAP Applications Processors	<a href="http://www.ti.com/omap">www.ti.com/omap</a>
Wireless Connectivity	<a href="http://www.ti.com/wirelessconnectivity">www.ti.com/wirelessconnectivity</a>

### Applications

Automotive and Transportation	<a href="http://www.ti.com/automotive">www.ti.com/automotive</a>
Communications and Telecom	<a href="http://www.ti.com/communications">www.ti.com/communications</a>
Computers and Peripherals	<a href="http://www.ti.com/computers">www.ti.com/computers</a>
Consumer Electronics	<a href="http://www.ti.com/consumer-apps">www.ti.com/consumer-apps</a>
Energy and Lighting	<a href="http://www.ti.com/energy">www.ti.com/energy</a>
Industrial	<a href="http://www.ti.com/industrial">www.ti.com/industrial</a>
Medical	<a href="http://www.ti.com/medical">www.ti.com/medical</a>
Security	<a href="http://www.ti.com/security">www.ti.com/security</a>
Space, Avionics and Defense	<a href="http://www.ti.com/space-avionics-defense">www.ti.com/space-avionics-defense</a>
Video and Imaging	<a href="http://www.ti.com/video">www.ti.com/video</a>

### TI E2E Community

[e2e.ti.com](http://e2e.ti.com)